

### List of Journal Published

Name of The Faculty Member	No. of Journals published	Page Number
Dr.C.Krishnakumar	8	2
Dr.S.Vijayalakshmi	20	10
Dr.M.V.Suganyadevi	20	30
Mr.B.Paranthagan	6	50
Mr.R.Balasubramanian	2	57
Dr.K.Rajkumar	3	59
Dr.M.Marimuthu	16	62
Dr.P.Ram Prakash	7	78
Ms.C.Pearline Kamalini	5	84
Mr.S.Ramprasath	7	89
Mr. P. Ramesh babu	8	96
Mr.R.Satheesh	1	106
Mr.R.Sridhar	1	107
Mr.R.Vijay	4	108
Ms.N.Gayathri	4	112
Mr.R.Venugopal	4	117
Dr.P.K.Arunkumar	3	121



# Detection and classification of multi-complex power quality events in a smart grid using Hilbert–Huang transform and support vector machine

C. K. Hemapriya<sup>1</sup> · M. V. Suganyadevi<sup>1</sup> · C. Krishnakumar<sup>1</sup>Received: 6 December 2019 / Accepted: 24 March 2020 / Published online: 6 April 2020  
© Springer-Verlag GmbH Germany, part of Springer Nature 2020

## Abstract

This article examines the potential ability of a chosen Hilbert–Huang transform (HHT) in detecting and identifying a multi-complex electric power quality events (PQE) signal in smart grid power systems under various noise situations. HHT is an active signal processing technique, comprising the units of empirical mode decomposition (EMD) and Hilbert spectral analysis (HSA) to detect the non-stationary electric signals. The function of EMD is to detect and decompose the non-stationary electric signal in different scales of frequency modules ranging from maximum to minimum values, and thereby the attained signals are characterized as intrinsic mode functions (IMFs). HSA details the IMF signals individually to produce a unique Hilbert spectrum which carries the information of original signal. By observing the instant time-varying deviations of frequency and amplitude of the resultant signals, it is possible to categorize the disturbing signals from the original signal. The discussed slots of work is simulated under MATLAB environment, and the results report that the HHT successfully detects the single PQE, complex PQE and multi-complex PQE signals under 25 dB, 50 dB and without noise situations. The outcomes of HHT technique are compared with other transforms such as S-transform and wavelet transform to highlight superior qualities of HHT. The identified PQE signals from HHT are classified using support vector machine to improve its classification accuracy. It is wiser to disclose that the proposed system with inbuilt monitoring and identification of PQE signals will suit present smart grid system.

**Keywords** Empirical mode decomposition · Hilbert–Huang transform · Intrinsic mode functions · Power quality · Support vector machine · S-transform · Wavelet transform

## Abbreviations

ANN	Artificial neural network
ARTMAP	Adaptive resonance theory map
CWT	Continuous wavelet transform
DFT	Discrete Fourier transform
DOST	Discrete orthogonal S-transform
ELM	Extreme learning machine
EMD	Empirical mode decomposition
FFT	Fast Fourier transform
FNN	Feed-forward neural network
FPGA	Field programmable gate array

FT	Fourier transform
FTTT	Fast time–time transform
GA	Genetic algorithm
HHT	Hilbert–Huang transform
HST	Hyperbolic S-transform
IMF	Intrinsic mode functions
MNN	Modular neural network
NM	Not mentioned
NN	Neural network
PDF	Probability density functions
PNN	Probabilistic neural network
PQ	Power quality
PQE	Power quality event
PSO	Particle swarm optimization
RBDT	Rule-based decision tree
RMS	Root mean square
RVM	Relevance vector machine
SAX	Symbolic aggregate approximation

✉ C. K. Hemapriya  
hemapriya.ck@gmail.com

<sup>1</sup> Department of Electrical and Electronics Engineering,  
Saranathan College of Engineering, Tiruchchirappalli,  
Tamilnadu, India

# Wireless Battery Monitoring System with Live Tracking for an Electric Vehicle

<sup>1</sup>\*S.Ramprasath, <sup>2</sup>Dr.C.Krishnakumar, <sup>3</sup>P.Rameshbabu

<sup>1,2</sup>Electrical and Electronics Engineering,  
<sup>1, 2, 3</sup> Saranathan college of Engineering, Trichy, India

**Abstract:** This paper presents a system to govern the battery parameters like voltage, charging/discharging current, temperature and location which helps in tracking the vehicle. In the developing technological sectors, electric vehicle is taking up its fast approach to its peak in the market and it's important to protect the system from fault and alerting the system. The major cost investment for an electric Vehicle is their Li-Ion batteries costs about half the total investment for the vehicle. Hence it's necessary to propose a Wireless battery management system (WBMS) which monitor the battery performance and for protection which increases longevity of the battery present in the electric vehicle. In our project we propose a control monitoring system which sense the live parameters and monitors remotely using ESP8266 Wi-Fi module interfaced with Arduino Uno Board. We use Blynk app to interface with different sensors. The completed model is place in our electric vehicle built to Participate in NSVU event help in Nagpur and won second overall prize.

**Keywords:** Battery, Li-ion, Blynk app

## 1. Introduction

In focus towards e-vehicle the major sector to be concentrated is battery. To examine the battery and its related parameters a flexible and compact system is build. Battery plays a major role in the operation of the e-vehicle, it is essential to govern the battery parameters and expand the life time of a battery. The quest to increase the span of an e-vehicle can be solved by governing the battery parameters related to voltage and current [1]. To process the same we need an interfacing medium which transmits the information to our smartphone. Blynk is the interfacing app which facilitates the interfacing between the system and smartphone. This app must be installed in our mobile phone to get the voltage and current parameters with the live location of our vehicle. In battery monitoring system we are about to implement a system that monitors the discharging voltage of the battery, current of the battery and live tracking of our car. Thus the life span of the electric vehicle can be protected from the undesired problems. Sensors are used to sense the parameters like current and voltage. Live tracking is also implemented to get the live location of our car. GPS module is used for tracking [2]. By doing this the life span of the battery can be increased with an added advantage of guiding the people with good platform. Cell balancing, Malfunction indication, status indication can be maintained.

In Electric Vehicles (EVs) the cells are connected in series-parallel combination to build high voltage and large capacity battery packs [3]. Factors causing cell voltage variation includes manufacturing methods, maintenance procedure and aging. In drive mode, these cells undergo electric and thermal ill-treatment due to the unpredictable load variations. In order to meet safety standards and to increase the battery life, a battery monitoring system (BMS) [4], [5] which properly monitors and controls each cell at every instant is mandatory. The WBMS was designed to minimize the Functionality of the slave module to only perform simple commands and send cell operating parameters. The master module is responsible for interpreting all of the data and deciding upon the actions the slave module should be taking [6], [7]. Figure 1 shows the overall block diagram of proposed WBMS. The proposed WBMS consists of a) Sensing module, b) Power supply module, c) Wireless Bluetooth module.

# Performance Analysis of Slope-Compensated Current Controlled Universal PV Battery Charger for Electric Vehicle Applications

Proceedings of International Conference on Power Electronics and Renewable Energy Systems pp 407-415 | Cite as

- S. Ramprasath (1) Email author (ramprasath-eee@saranathan.ac.in)
- R. Abarna (1)
- G. Anjuka (1)
- K. Deva Priya (1)
- S. Iswarya (1)
- C. Krishnakumar (1)

1. Saranathan College of Engineering, , Trichy, India

Conference paper

First Online: 22 November 2021

- 74 Downloads

Part of the [Lecture Notes in Electrical Engineering](#) book series (LNEE, volume 795)

## Abstract

The main purpose of the proposed system is to design a low-cost universal PV battery charger for electric vehicle application. The proposed system is integrated with a slope-compensated current controller which controls the charging current that corresponds to maximum power point of the PV module. As an interface converter, the proposed system consists of a buck converter to control the flow of the charging current and to find out the reference current  $I_{ref}$  from the PV array at MPP. The battery control circuit is implemented by measuring the state of charge (SOC) of the battery, and an LCD display has been used to monitor the battery parameters. This proposed system acts as a smart and efficient PV battery charger for e-vehicles.

## Keywords

Electric vehicle Battery charger State of charge Slope compensated

This is a preview of subscription content, [log in](#) to check access.

## References

# Simulation and Steady State Analysis of SIMO Boost Converter for Electric Vehicles

**Publisher:** IEEE

[Cite This](#)

[PDF](#)

C. Keerthika ; S. Ramprasath ; P. Rameshbabu ; C. Krishnakumar [All Authors](#)

76

Full

Text Views



## Abstract

### Document Sections

- I. Introduction
- II. Simo Converter Topology
- III. Steady State Analysis
- IV. Simulation Results
- V. Conclusion

### Authors

### Figures

### References

### Keywords

### Metrics

## Abstract:

Extreme environmental and human life issues such as global warming, air pollution and the rapid loss of oil resources in the planet are caused by the vast number of cars used. To overcome these issues traditional vehicles have been replaced by the Electric vehicles (EVs). To communicate the elements in the E-Vehicle DC-DC converters are used, by increasing or decreasing the input voltage levels. In order to efficiently reduce the quantity of electronic components to get different output voltages, Single-input Multiple-output DC-DC converters have been developed, also reduces cost. The SingleInput Multi-Output(SIMO) dc-dc converter delivers various levels of output voltage required by the load from a single source of dc input voltage. There are many SIMO topologies were evolved. In order to achieve the above limitations, in this project our work is to model a Single-Input Multiple-Outputs Boost converter. The suggested converter would uplift the voltage to a controllable middle voltage and high voltage dc output from a low voltage input power source. To validate the proposed topology for real time applications, the proposed converter is simulated in the MATLAB application.

**Published in:** 2021 2nd International Conference for Emerging Technology (INCET)

**Date of Conference:** 21-23 May 2021

**INSPEC Accession Number:** 20867097

**Date Added to IEEE Xplore:** 22 June 2021

**DOI:** 10.1109/INCET51464.2021.9456358

► **ISBN Information:**

**Publisher:** IEEE

**Conference Location:** Belagavi, India

# DESIGN OF INPUT QUALITY CURRENT RECTIFIER BASED ON LUO TOPOLOGY IN MATLAB/SIMULINK ENVIRONMENT

Mr.P.RameshBabu <sup>1</sup>, Dr.C.Krishnakumar <sup>2</sup>, S.Kiruthiga <sup>3</sup>

Assistant Professor <sup>1</sup>, Professor & Head <sup>2</sup>, PG Scholar <sup>3</sup>

Department of Electrical and Electronics Engineering, Saranathan College of Engineering, Trichy, India

**Abstract**— This paper presents a new control scheme that deals with an active input power factor correction with single phase bridge rectifier fed LUO Converter Topology using Hysteresis current control Technique to compensate the harmonic current generated by the Diode Rectifier so as to achieve a power factor nearer to unity and to regulate the DC bus voltage. The comparison of an inductor current and ramp carrier waveform gives the Duty cycle which is associated with Hysteresis Controller in each switching period. The Hysteresis current controller is used to track the line current command. Benefits of this proposed Converter are high power density, Simple control strategy, less harmonic control content, nearly unity power factor and unidirectional power flow. As a result, the input current waveform is sinusoidal and in-phase with supply voltage having high power factor.

**Keywords**— Hysteresis current control, Voltage Gain, Power factor.

## I. INTRODUCTION

In our Day-to-day life, there is much importance to DC-DC Converter for satisfying domestic, Business, Agricultural and industrial needs. The utilization of DC-DC converters are increased because of the vast applications in various fields. In Transmission and Distribution networks, a serious power problem is created due to non-linear loads. For boosting the voltage in DC-DC converter circuit, Voltage-lift and Super-lift Technique are used. These techniques have been employed in DC-DC converters and used to Design high voltage gain converters. Voltage lift Technique increases the output voltage in Arithmetic progression, whereas the super-lift technique increases output voltage in Geometric progression. This technique enhances the voltage transfer gain effectively. The low power factor and high pulsating current from the AC mains are the main disadvantages of Diode rectifier in LUO topology which results in line voltage distortion, heating of core Transformer and Electrical Machines, increasing losses in transmission and distribution system.

In order to meet the required qualities of the current harmonics, the power factor correction is used to eliminate the harmonic current generated by the Diode Rectifier. The passive power factor correction method can reduce the harmonics up to some limit, but it cannot overcome the non-

characteristic Harmonics. This can be overcome by using active power factor correction method.



# Design and Simulation of MPPT Control for Solar Powered AC Autonomous LED Lighting Applications in MATLAB/Simulink Environment

P. Ramesh Babu, C. Krishnakumar, S. Kiruthiga

**Abstract:** As an AC LED light applications have become a commonplace item of light industry, it has a wide range of usage in garden lighting, cove lighting, office lighting and retail applications. The paper brings out the utilization of Boost converter along with Maximum Power Point Tracker (MPPT) technique for the control of Photovoltaic power. This proposed system which includes Boost converter, a single phase full bridge inverter with Sinusoidal Pulse Width Modulation (SPWM) technique. The main concept of this converter includes designing of boost converter that provides an output voltage of 350V DC and single phase SPWM provides 350V, pure sine wave output (230V RMS) applicable to AC autonomous LED Lighting system. In order to bring out a transformer free inverter, the designed boost converter is simulated in the MATLAB Simulink software and the results are shown with low THD as per IEEE standard, with acceptable power factor and higher efficiency.

**Keywords:** MPPT; Perturb and Observe Algorithm; Boost converter; Inverter, SPWM.

## I. INTRODUCTION

Industrial and Domestic energy production widely depends on a limited resource. Energy usage is playing an important role in day today's life. As electricity can be generated by burning the fossil fuels which leads to major drawback of severe/drastring climatic changes such as acid rain, global warming etc.,

In order to overcome these drawbacks, solar energy is widely used as the major source of energy for the generation of electrical energy from the photovoltaic array [5].

The step up or step down transformer used for the conversion of voltage in traditional inverters faces major drawbacks of its large size, higher total harmonic distortion and being high-priced.

These disadvantages are eliminated in this paper by introducing a single stage step up converter, to form a compact, inexpensive transformer free inverter. Maximum power point tracking (MPPT) mechanism is used for the extraction of maximum possible power using the Perturb and Observe algorithm from the PV array, which is considered as the most popular conventional method for capturing the required maximum power. This proposed system brings out a transformer less inverter which supports the benefits of having reduced size, compact, less priced and with low Total Harmonic Distortion (THD). Sinusoidal Pulse Width Modulation (SPWM) is generated by comparing the reference signal along with the triangular carrier wave and used for gating purpose in an inverter [12]. Finally, the proposed system is designed mathematically and simulated in MATLAB/Simulink software to verify the performance of various subsystems.

## II. BLOCK REPRESENTATION OF PROPOSED MPPT SYSTEM

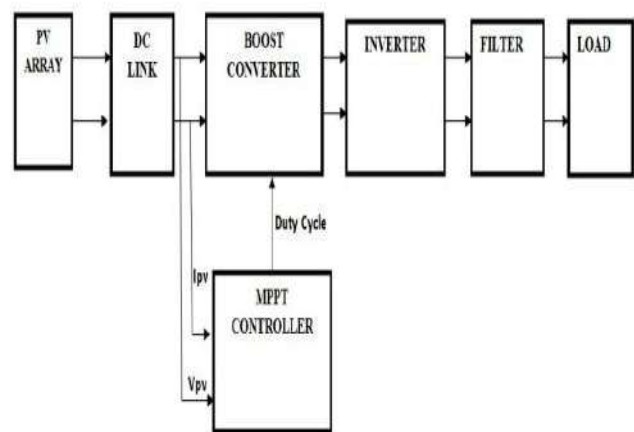

**Fig.1. Block representation of MPPT configuration**  
PV cells or arrays are the power source of the system, which are modeled by an equivalent circuit and simulated to show the exact behavior of a PV array. Then, the two power converters are used for the control of,  
1) Extracting maximum power  
2) Deliver of power to AC grid with an acceptable THD and Power Factor.

Revised Manuscript Received on March 17, 2020.

\* Correspondence Author

**P.Ramesh Babu\***, Assistant Professor in the department of EEE in Saranathan College of Engineering, Trichy.

**Dr.C.Krishnakumar**, Professor/Head in the department of EEE in Saranathan College of Engineering, Trichy.

**S.Kiruthiga**, PG Scholar in the department of Power Electronics and Drives in Saranathan College of Engineering, Trichy.

© The Authors. Published by Blue Eyes Intelligence Engineering and Sciences Publication (BEIESP). This is an open access article under the CC BY-NC-ND license (<http://creativecommons.org/licenses/by-nc-nd/4.0/>)



NO ACCESS

# Hybrid PWM modulated cross switched asymmetrical multilevel inverter with reduced number of conducting devices

Thamizharasan Sandirasegarane, J. Maalmarugan and C. Krishnakumar

Published Online: 15 Dec 2020



PDF



Abstract &amp; Keywords



Tools



Share



Figures



References



Related



Details

## Information

Copyright © 2021 Inderscience Enterprises Ltd.

## Keywords

field programmable gate array

pulse width modulation inverters

hybrid PWM

reduced gate drivers

## Authors and Affiliations

Thamizharasan Sandirasegarane<sup>1</sup>J. Maalmarugan<sup>2</sup>C. Krishnakumar<sup>3</sup>

1. Department of Electrical and Electronics Engineering, Saranathan College of Engineering, Tiruchirapalli, Tamilnadu-620012, India

## Abstract

This paper brings out a new topology for a cascaded multilevel inverter (CMLI) with a view to reduce the number of power switching devices in the path of the current. The philosophy suggests the integration of a low voltage pulse width modulated (PWM) inverter along with a high voltage fundamental switching inverter to produce the specified number of output levels by switching the series connected DC sources of high voltage inverter in an additive and or subtractive combination with low voltage PWM inverter. It invites a hybrid PWM approach to the process of generating the pulses for synthesising the stepped nature in conjunction with the variable pulse width output. The use of a smaller number of switches to reach the output voltage show cases the ability of the modular architecture to expand the scope of CMLI. The artefacts of a field programmable gate array (FPGA) factor to realise its implementation in pulse generation for switching the devices and verifi-





# A carrierless pulse-width modulation strategy for three-phase cross-switched multilevel inverter using area equalization method

Rajkumar Kuppapillai<sup>1</sup> · Thamizharasan Sandirasegarane<sup>2</sup> · Krishnakumar Chittibabu<sup>1</sup>

Received: 8 July 2021 / Accepted: 18 November 2021  
© The Author(s), under exclusive licence to Springer-Verlag GmbH Germany, part of Springer Nature 2021

## Abstract

Multilevel inverters (MLI) are preferred for high voltage, medium power applications due to their ability to synthesize the stepped waveform nearly to a sinusoidal voltage. However, it has several issues like, increased number of devices, higher blocking voltage and power loss in higher voltage levels. Additionally, the traditional pulse-width modulation (PWM) applied to MLI is simply an extension of three-level inverter PWM and it becomes cumbersome at higher voltage levels. Therefore, this research article proposes a PWM strategy without carrier and reference signals. This concept equates the area under target fundamental output voltage to that of actual output voltage. In the proposed PWM strategy, a mathematical model is developed to compute the position of the pulse and the width of the pulse using centroid technique and equal area criteria, respectively. The proposed strategy is generalized to any preferred levels with reduced complexity in implementation. The simulation results of the proposed strategy showcase better performance indices. Gate pulses are generated by Xilinx Spartan 3E FPGA controller in experimentation. The experimental investigation of the three-phase five-level inverter prototype gives the results confirming the capabilities of the proposed strategy in real-time applications.

**Keywords** Area equalization · Multilevel inverter · Centroid technique · FPGA · PWM

## 1 Introduction

The emergence of multilevel inverters makes helpful in supplying high power and medium voltage industrial applications which fits its use broadly in domestic needs. Several researches have been put forth to develop dedicated modulation strategies for particular topologies or to bring an amalgamation in traditionally tailored control strategies to operate the topologies for level synthesizer with the aim of good performance indices. On the basis of carrier phase disposition PWM (PDPWM), Zhao et al. [1] developed a higher and lower carrier cells alternative phase opposition PWM for the hybrid-clamped multilevel inverter constructed by reduced number of devices. This strategy claims to operate over a broad range of modulation indices, reduced switching losses and lower amplitude of lower harmonics. Zhang and

Lum [2] introduced a novel pulse-width modulation scheme in flying-capacitor asymmetric H-bridge inverter with the positive and negative cross-carriers to control the flying-capacitor voltage by utilizing the redundant switching states of the output voltages and three modes of pre-charging the flying capacitor without extra equipments. The capacitance of the flying capacitor and the switching frequency of the power switches are selected based on the allowable voltage fluctuation across the flying-capacitor and the load current. A novel minimized loss DPWM method is developed by varying the offset based on peak values of three-phase load currents and as a result of avoiding commutations at high currents with reduced switching loss for multilevel inverters [3]. A generalized pulse-width modulation approach developed within the carrier-based PWM by Grigoletto and Pinheiro [4] to eliminate both the low-frequency oscillations and imbalances of the dc-link capacitor voltages in four or more level diode clamped multilevel inverters. The four different sequential switching hybrid-modulation strategies comprised of fundamental-frequency modulation and multilevel sinusoidal-modulation (MSPWM) strategies for cascaded multilevel inverters are developed in [5], with the characteristics of the reduced switching losses, good har-

✉ Rajkumar Kuppapillai  
avk.rajkumar@gmail.com

<sup>1</sup> Department of Electrical and Electronics Engineering, Saranathan College of Engineering, Tiruchirappalli, India

<sup>2</sup> School of Engineering and Technology, Surya Group of Institutions, Vikiravandi, India

# PERFORMANCE EVALUATION OF CASCADED BOOST CONVERTER

M.Gomathi<sup>1</sup>, S.Vijayalakshmi<sup>2</sup>.

PG scholar, EEE, Saranathan College of Engineering,Trichy,India<sup>1</sup>

Associate professor, EEE, Saranathan College of Engineering,Trichy,India<sup>2</sup>

**Abstract**— This paper presents cascaded boost converter with less current stress and high voltage gain for fluorescent lamp applications. Normally boost converters are used to boost dc voltages as double as the input voltage with low voltage gain. Cascaded boost converter boosts the input voltage to higher levels with high voltage gain .The converter passive elements values are theoretically calculated using design equations. Theoretical analysis and simulation results are given confirming the decrease in input current and switching stress while delivering high output voltage for high power applications.

**Keywords**— cascaded boost converter, duty cycle.

## I. INTRODUCTION

For high voltage gain, easy implementation and better performance, the cascaded boost converter are suitable. DC to DC converters are widely used for applications like renewable energy systems and various other industrial applications. It involves various topologies in various type of converters. Out of these topologies boost converter is widely used for boosting the stored energy to higher values in the case of renewable energy systems. A boost converter is a dc to dc power converter that provides an output voltage greater than the input voltage. But it usually provides an output voltage as double as the input voltage or a little higher. In order to get higher output voltages cascaded boost converter are employed. Cascaded boost converter consists of two basic dc to dc boost converter connected in cascade and the output voltage of cascaded boost converter is having high voltage gain. [1][6][7]

Cascaded boost converter converts dc input voltage into boosted dc output voltage. Input dc voltage either from battery or PV panel .Boosted dc output voltage is given to suitable loads such as lighting and telecommunication applications .A 24 v dc input voltage boosted to 110 v dc output voltage by adjusting duty cycle ratio (D). In cascaded boost converter. Therefore, by adjusting duty cycle desired output voltage can be obtained. This circuit is designed for 30watts.While designing of cascaded boost converter it is essential to consider per unit inductor ripple current ( $\Delta i_L/i_L$ ) per unit inductor ripple voltage ( $\Delta V/V_c$ ). Considering a frequency  $f=50$  kHz.

## II. SYSTEM MODEL

The circuit diagram of the conventional dc to dc cascaded boost converter is shown in fig.1. It has two operating modes. The equivalent circuits of the converter operating in the two modes are shown in fig.2 and fig 3.respectively.

# DESIGN OF SEPIC CONVERTER FOR RENEWABLE ENERGY APPLICATIONS

J.SHERRIN BANU <sup>[1]</sup>, DR.S.VIJAYALAKSHMI<sup>[2]</sup>,M.MARIMUTHU<sup>[3]</sup>

*PG Scholar, Dept. Of EEE, Saranathan College Of Engineering, Trichy, India<sup>[1]</sup>*

*Associate Professor, Dept. Of EEE, Saranathan College Of Engineering, Trichy, India<sup>[2]</sup>*

*Assistant Professor, Dept. Of EEE, Saranathan College Of Engineering, Trichy, India<sup>[3]</sup>*

**Email id:** sherrinbanu2@gmail.com

## ABSTRACT

Design of the power electronics circuitry are now -a-days reducing the size, space and weight of the converter/ inverters circuits. This is possible because of the availability of new high switching frequency devices. This paper represents the analysis performance of SEPIC converter for renewable energy applications. This converter is used in buck as well as in boost mode.

The SEPIC converter is designed, analyzed and simulated. The proposed model of the SEPIC converter consist of two parts: (i) main converter components like switch, Inductors, Diodes, Capacitors, and a Load.,(ii) a control circuit for controlling the duty cycle using ARDIUNO .

To verify the proposed model, the circuit is prepared and their experimental results were compared with the results obtained by simulation of the circuit in PROTEUS and MATLAB.

## KEYWORDS :

SEPIC converter ,switch, inductors, diodes, capacitors, and a load, duty cycle, ARDIUNO, PROTEUS, MATLAB.

THE DC-DC converter is a dc power supply that is small, light in weight and highly efficient and uses a semiconductor switching elements. It can respond quickly and suitable to change in input voltage. The dc input voltage to the converter is assumed to have zero internal impedance. The SEPIC is a type of DC-DC converter allowing voltage at its output to be either greater than or lesser than or equal to its input voltage. The output voltage of the converter is controlled by controlling the duty cycle of the MOSFET.

A Sepic converter is a Boost converter followed by a buck boost converter, but has advantage of having the output voltage polarity same as that of the input voltage .a coupling capacitor transfers the energy from the input to output . During ON time the diode is reverse biased due to negative polarity of coupling capacitor and inductor  $L_2$  and inductor  $L_1$  is charged through source and coupling capacitor is discharged.

During OFF time the switch  $L_1$  charged coupling capacitor and  $L_2$  transfers energy to the output diode is forward biased in this case.

## I.INTRODUCTION

## II. ANALYSIS OF SEPIC CONVERTER

# DUAL AXES SOLAR ENERGY TRACKING POWERED AUTOMATIC HOME LIGHT CONTROL

J.SHERRIN BANU<sup>[1]</sup>, Dr.S.VIJAYALAKSHMI<sup>[2]</sup>

PG Scholar, Dept. Of EEE, Saranathan College Of Engineering, Trichy, India<sup>[1]</sup>

Associate Professor, Dept. Of EEE, Saranathan College Of Engineering, Trichy, India<sup>[2]</sup>

Email id: sherrinbanu2@gmail.com

## ABSTRACT

Solar DC system with DC-DC Sepic converter is more efficient than the system incorporating inverters. It consist of a solar photo voltaic panel, solar charge controller, DC-DC Sepic converter, batteries and LED (load). The solar energy is obtained using Dual Axes Solar Power Tracking System with LDRs. The maximum power point tracking (MPPT) Solar Charge controller is used to ensure that the maximum amount of generating power is transferred to the load and can also be stored in the batteries for future use. As an application in *Home Energy Management System*, Passive Infra Red (PIR) sensor automatically controls room lights and fan base on the presence of humans. Based on the solar light intensity, automatic room light and fan are controlled using LDR. This method overcomes the conversion of AC-DC and DC -AC which reduces the cost of power production per unit watt power.

**KEYWORDS:-** DC-DC SEPIC converter, batteries, LED, Passive Infra Red (PIR) sensor, LIGHT DEPENDENT RESISTOR LDR.

## I. INDRODUCTION

Most of the devices or household equipments operate on DC power. We can obtain DC power easily from abundantly available Solar energy which provides enough energy in one minute to provide for world's energy requirements for one year. Due to energy demands, increasing environmental problems and declining fossil fuel resources, we focused our attention on Solar energy – one of the most priming renewable energy sources in the world.

The average home has enough roof area to produce Solar electricity for its power needs. A Solar home look and operate like a home connected to the power line. PV panels ar getting used more and more, both in the city and in remote locations, to produce electricity for households, schools and communities, and to supply power for equipment such as telecommunication and water pumps. Generally, room mechanization consisting of sensing elements which collects different kinds of data like environmental parameters along with electrical parameters.

The demands for electricity keep increasing year by year, however the most resources that are oil, gas and coal are depleting. Solar energy, which is one of the types of renewable energy, has been recognized by the government as the best initiative in order to solve this problem. It is also related to the aspects of deforestation control, protection of the ozone layer, reduction of CO<sub>2</sub> emission and so on. Solar energy will replace the bulky, expensive, inefficient inverters. It can be stored in Batteries. It takes 50% lesser space as compared to the AC solutions. As the DC appliances are safer than the 230v AC appliances, no worry from electric shocks and also DC appliances have higher reliability and gives a far better life span.

## II.SYSTEM ARCHITECTURE

The block diagram of the Solar Energy Based DC Home Using Dual Axes Tracking And Automatic Room Light Control is shown in the Fig 1.1.

# MODELLING AND SIMULATION OF HYBRID (WIND and SOLAR) FOR DC MICROGRID

S.Priya

*PG Student, Dept Of EEE,*

Saranathan College Of Engineering, Trichy,

E-Mail-priyamalathy13gmail.com

M.Marimuthu,

*Assistance prof, Dept Of EEE,*

Saranathan College Of Engineering, Trichy,

E-Mail-marimuthuoffice@gmail.com

S.Vijayalakshimi

*Associate prof, Dept Of EEE,*

Saranathan College Of Engineering, Trichy,

E-Mail-bksvijji@gmail.com

S. Prassanna Perumal,

*PG Student, Dept Of EEE,*

Saranathan College Of Engineering, Trichy,

E-Mail-prassannaex@gmail.com

## ABSTRACT:

This paper deals with the development of DC Micro grid using Hybrid Wind/Solar power system using MATLAB/SIMULINK. The hybrid of small modular device such as PV, small wind turbine and storage device and it given to DC load is known as DC microgrid. Wind/Solar hybrid power system is used to improve the energy efficiency and the LED'S are useful for power cost. LED'S are energy saving, high luminous efficiency and very much useful life. LED (Light Emitting Diode) street light system play an major role and run in DC power with the increased use of Hybrid power system, Since the irradiance of pv panel and speed of the wind turbine is variable this is controlled by power electronics device. Here buck and boost converter is used for both the energy. The proposed system was canvas in consider to the operation status of the hybrid input power and battery voltage using MATLAB simulation. The hybrid system is determined by simulating using MATLAB/SIMULINK.

**Keywords:** (Solar, Wind, Boost and Buck Converter, MPPT and PID controller, DC Microgrid)

## I. INTRODUCTION

In present day a huge problem in many countries is power demand, so we move to Renewable energy that we integrated the solar and wind energy. The global insight of renewable energy in power system is rapidly increasing for wind and solar energy system. Amount of solar power and wind power integration increases it can

be created technical challenges to the grid Power system due to solar and wind power is naturally sporadic. The size of the battery storage energy belong to intermittency level of the solar or wind .In summation if solar or wind are used to supply the power to a stand-alone system, energy storage system becomes essential to assure that power supply is continuous.

## A. WIND ENERGY

The popular field of technology is wind energy so it has many developments laying ahead the wind power industry is one of the fastest expanding industries as a result of rapid growth of installed capacity. In Fig.1 depicts the generation of Power using Windmill. This is the renewable energy sources for taken from wind mill. The generation of electricity from wind energy has less installation and maintenance. We can produce the energy almost 24 hours of the day. Initial cost also less for this kind of system.

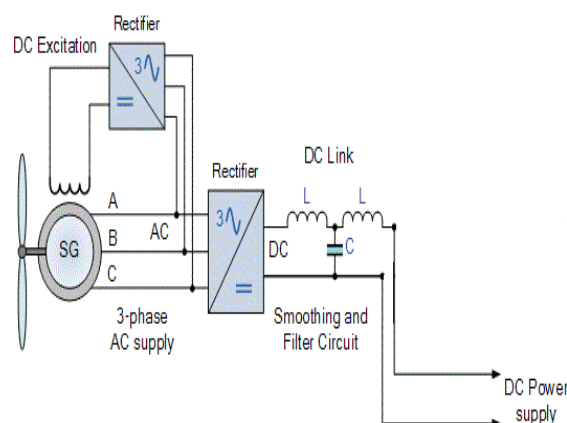

Fig. 1 Generation of power using Wind mill

# PLC BASED ALARM/TRIP STATUS FOR MONITORING GENERATOR TRANSFORMER

**J. Senthilnathan, S. Vijayalakshmi, R.S. Priyaadharshini**

<sup>1</sup>Senior Lecturer/EEE, Government Polytechnic Colleg, Trichy – 22

<sup>2</sup>Associate Professor/EEE, Saranathan College of Engineering, Trichy – 12

<sup>3</sup>Assistant Professor/EEE, Saranathan College of Engineering, Trichy - 12

## Abstract :

This paper deals with automation of cooling circuit in transformers using PLC. At present, relays and timers are used to control the temperature of oil using EMR (Electro-Mechanical Relay) logic. Probability of faults is more in this control logic. Hence, PLC is introduced in place of present control logic to control the temperature within limits. The PLC program is implemented using LADDER logic and simulation is done using ZEN software.

**Keywords:** Cooling Circuit, Fire Protection System, Generator Transformer, PLC.

## 1. INTRODUCTION

Transformer is the most important equipment in transmission line grid. Generator transformers are located between generator and grid through switch gear. Winding part and radiator bank area are separated and are linked through huge pipe carrying oil with pumps. Temperature of oil and winding in the transformer plays a major role [1-2] and it has to be controlled within limit. To limit the temperature within limit, control circuit is employed. Large numbers of control relays are required for this circuit. The increase in number of relays makes the wiring complex and difficult. In this case of hard-wired logic, frequent maintenance and occasional replacement of contact is required. The maintenance cost will be more. Probability of faults is undoubtedly high and hence automatic protection is absolutely necessary [2].

EMR circuits used at present system are used to start/ stop cooling fans and oil pumps, to monitor oil level and oil flow and float (top and bottom float) in Buchholtz relay – thereby initiating Alarm and Trip signals. This existing system with relays and timers is being modified

using PLC. Automation provides all possible protection and accordingly Alarm / Trip signals are produced for the fault situation. The greatest advantage of using PLC technology is Personal computer (PC) connectivity [2-4] i.e. PC friendly [2-4]. The application is totally written as software and hence physical control relays, timers and its associated wiring can be avoided. This system is reliable compared to the existing system [5-6].

## 2. EXISTING SYSTEM

In this system, oil and winding temperature is monitored and signals are given based on EMR and timers. The cooling system of the G.T is mainly subdivided into three categories. They are as follows,

1. ONAN (Oil Natural Air Natural)
2. ONAF (Oil Natural Air Forced)
3. OFAF (Oil Forced Air Forced)

During the normal operation of the system, ONAN type cooling is used. When the temperature exceeds beyond 55°C, fan series starts and hence ONAF type cooling comes into action. When the temperature exceeds further about 65°C, oil pump series starts and hence OFAF type cooling is performed.

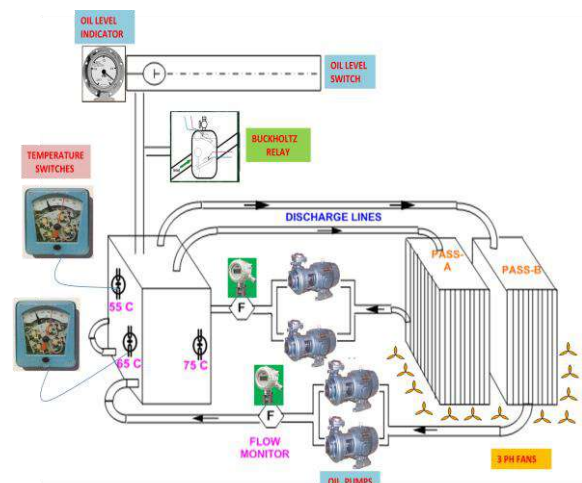

**Fig. 1 Generator Transformer monitoring**

# Design and Analysis Of Quadratic Boost Converter

M.Priyanga<sup>1</sup>, B.Paranthagan<sup>2</sup>, Dr.S.Vijayalakshmi<sup>3</sup>, M.Marimuthu<sup>4</sup>

PG Scholar, EEE, Saranathan College of Engineering, Trichy, India<sup>1</sup>  
 Associate Professor, EEE, Saranathan College of Engineering, Trichy, India<sup>2,3</sup>  
 Assistant Professor, EEE, Saranathan College of Engineering, Trichy, India<sup>4</sup>

**Abstract—** In this paper the simulation of a High gain DC-DC Quadratic Boost Converter is presented. Operation of the QBC is analyzed, leading to mathematical expressions that can be used to design a converter. Based on the derived analytical expressions, a 200W, QBC converter is designed. The proposed quadratic boost converter implemented in MATLAB/SIMULINK.

**Keywords—**DC-DC converter, Quadratic Boost Converter

## I. INTRODUCTION

In recent years for a great number of appliances dc-dc converter is employed. Normally in renewable energy system, the system having low output characteristics to recover this demand DC-DC converter topology is implemented. For maintaining the output DC voltage range in PV array and fuel cells, converter is wont to improve the output voltage. But during the switching operation the voltage stress is high. While selecting the converter the concentrating options are; once switch is activate it should attain the zero voltage crossing, when PhotoVoltaic array is connected to the grid the converter should ought to offer the high terminal voltage for low input vary. The converter which provides the high output vary at low voltage stress is a lot of economical. Voltage gain typically supported duty magnitude relation thus by selecting the passive parts components the duty magnitude relation can be restricted.

## II. QUADRATIC BOOST CONVERTER

The circuit diagram of a quadratic boost converter is shown in Fig1. The circuit comprises of a single switch S, three diodes D1, D2 and D3, two capacitors C1 and C2, two inductors L1 and L2 and a load resistor R. The circuit operation is entirely in view of the supposition that the switch S is perfect in operation and capacitors C1 and C2 is

thought to be substantial so the voltage over the capacitors VC1 and VC2 are almost consistent over an switching period. At the point when the switch is ON: The comparable circuit schematic of the QBC amid the ON state is appeared in Fig 2.when switch S is turned on D2 is forward one-sided, while D1 and D3 invert one-sided. Currents are provided to L1 and L2 by Vin furthermore, C1 respectively.

At the point when the turn is OFF: The method for operation and current stream heading of QBC amid OFF state is appeared in Fig 3. In this condition D1 and D3 are forward biased, while D2 switch is reverse biased. L1 and L2 are charging C1 and C2 individually. During this state, iL1 and iL2 is diminished.

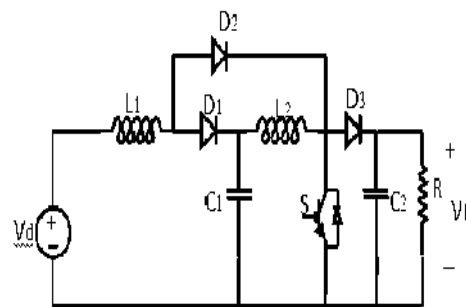

Fig1. Quadratic Boost Converter

## III. STEADY STATE ANALYSIS

Mode 1 (Switch S = on)

The equivalent circuit schematic of the QBC during the ON state is shown in Fig 3.6.when switch S is turned on D 2 is

# VULCOPTER

Dr.S.Vijayalakshmi, Ph.D ,  
Electrical and Electronics Engineering,  
Saranathan College of Engineering,  
Trichy- 620 012.  
[bksviji@gmail.com](mailto:bksviji@gmail.com)

Arun Prasath P A  
Electrical and Electronics Engineering,  
Saranathan College of Engineering,  
Trichy- 620 012  
[prasathanjaan@gmail.com](mailto:prasathanjaan@gmail.com)

Cyril Rozario B,  
Electrical and Electronics Engineering,  
Saranathan College of Engineering,  
Trichy- 620 012.  
[cyrilrozario33@gmail.com](mailto:cyrilrozario33@gmail.com)

Vignesh V & Kishore Kumar S  
Electrical and Electronics Engineering,  
Saranathan College of Engineering,  
Trichy- 620 012  
[vignesh.vijay11@gmail.com](mailto:vignesh.vijay11@gmail.com)  
[kishorekumar1216@gmail.com](mailto:kishorekumar1216@gmail.com)

## I. INTRODUCTION

An UAV Unmanned Aerial Vehicle is considered as a flying mission for different goals. This UAV constrains all host embedded components to grasp over the trained mission in which instructions were fetched into it. This flying platform is considered to be one of the future scope for a development. Here the UAV has a special mission, with the help of the IOT and CLOUD technology and artificial technology which will be a future for all fields. So this project will be useful in aerodynamic field. The UAV is mainly of two types: fixed and multi rotor wing. This is neither of the two types (multi rotor or fixed) which is an ornithopter. The vision of our project is to compete with the foremost firm. Our objective is to monitor, to hunt offender and to prison virtually.

EEE

February 8, 2019

### A. Components

Our objective is to monitor, to hunt offender and to prison virtually. The claws of our vulcopter are mainly designed for electrostatic charging and the transmitter 6 Channel 2.4 GHz paves a main advantage for our design as it ranges to 1 km. The thermal sensor, senses a person easily who are far from the point of vision and the long-range OEM camera looks distinct in our operation. MSP-430 is one of the texas instrument and a mixed-signal microcontroller used as it is a low consumption of power. It is given with the USART data which acts virtually outside the drone. In the USART, the transmitter transmits the signal to the reciever and the data recieved will gives the desired output. HC-SR04 is a obstacle detector which can be used to detect the obstacles, the drone going to face. Rather than those components, we use some other components such as electrostatic charge rectifier.

Transceiver 6CH receives the signal from the transmitter for appx. 1km radius with 2.4 GHz. Electronic speed controller (30A) is used to control the current entering the motor based on the load the current consumption may vary.

Motor @ No Load - ESC 5 - 10A

Motor @ Full load - ESC 20-25A

### B. Design:

The bird initially tries to take off its speed from initial condition with respect to the four components: Lift, Weight, Drag, Thrust are the main components of vulcopter. These components depends on one another for the resultant force exerted by a bird (ornithopter). The Resultant force is the vector sum of the magnitude of the lift and Thrust. The magnitude of drag and the thrust are in an angle nearer to 180 degree not equal to 180. Likewise Magnitude of lift and the weight resembles the same as that of the drag and the thrust. The direction of the flight depends on the thrust exerted by the body. The mathematical design of magnitude can be calculated with the help of the formula of force. The Thrust resembles as same as that of force, the force is nothing but the rate of change of momentum with respect to time.

$F = mv$  where

F=Force or thrust of the ornithopter

m=Mass of the object

v=Velocity by which the ornithopter moves

So force can be expressed in terms of mass and velocity. The thrust is produced by the engine in which the bird moves in a desired direction. The relationship with the mass and then weight is that , it is directly proportional to each other(weight=mass x acceleration).



# Analysis of PV Panel based Bidirectional Converter for Electric Vehicle

Vijayalakshmi S  
Department of EEE  
Saranathan college of Engineering,  
Trichy, India  
bksviji@gmail.com

Shivabalan N  
Department of EEE  
Saranathan college of Engineering,  
Trichy, India  
shivabalan1999@gmail.com

Thayananth.T  
Department of EEE  
Saranathan college of Engineering,  
Trichy, India

Marimuthu M  
Department of EEE  
Saranathan college of Engineering,  
Trichy, India  
marimuthueephd@gmail.com

Shathishkumar VK  
Department of EEE  
Saranathan college of Engineering  
Trichy, India  
shathishgokul@gmail.com

Venugopal. R  
Department of EEE  
Saranathan college of Engineering,  
Trichy, India  
venugopal-eee@saranathan.ac.in

Pravinraj T  
Department of EEE  
Saranathan college of Engineering  
Trichy, India  
pravinprince1122@gmail.com

**Abstract - This paper present an analysis of PV panel based Bidirectional converter for Electric vehicle charging. This system consists of solar cell battery, bidirectional dc -dc converter. A Battery is provided for supply power to dc motor during no sunlight condition. The bidirectional dc-dc converter is working in both charging and discharging the battery and can manage the flow of power in both the direction and hence excess energy from the PV panel can be stored in battery. MPPT controller extract maximum power from the PV module under the impact of varying irradiance and varying the load conditions. Model Performance evaluation and analysis has been done through MatLAB/Simulink**

**Keywords : PV panel, Bidirectional Converter, battery, Maximum Power Point Tracking (MPPT).**

## I. INTRODUCTION

Solar energy becomes the most challenging energy sources. In fact, a lot of domestic & industrial or commercial applications use solar energy. Solar energy is a key source to reduce Co2 emissions. On our country, ICE (Internal combustion Engines) are a major source of pollution, hence Electric vehicles become the promising solution. For many reasons taking into account, environmental and cost considerations, renewable energy sources such as solar energy is preferable to charge plug-in electric vehicles. In India, mostly IC engines where used for the transportation. In order to reduce environmental pollution and climatic change and increasing price of fossil fuels, Indian government encourages to promotes more and more electrical vehicles (EV). The Indian government set a target to accelerate the adoption of Electrical vehicles to reduce pollution and many other advantages like high torque and easy speed control. However, all IC engines have to be replaced by an energy storage battery with the help of suitable converter.

In [1] the authors propose an AC charging station with second life Li-ion battery, integrating solar PV, and wind energy. This station is grid connected which allows the export or import energy depending on the utilization. The authors in [2], [4] a control strategy of a multi-port, grid connected, direct DC PV charging station was proposed, the source of energy here can be either PV panels or AC grid, the transfer of energy from AC grid is bidirectional, hence, PV

energy can be injected on AC grid. These two topologies use many converters, which reduce efficiency. In [5] a charging strategy is proposed to minimize the energy cost, the charging time is divided into intervals to minimize the peak consumption of a fleet of EVs during day time. The charging station in this case is grid connected; in addition, the topology was not given.

The effect of fast charging EVs on the AC grid was investigated in [8]: the charging station in [8] is a DC fast charging, and only the grid is used as energy source. The energy source is not renewable and the efficiency is decreased by using two converters. Four possible architectures for a solar EV charger are proposed and compared in [9], these configurations are also grid connected, two possible choices for interconnection to the AC grid: AC inter-connection or DC inter-connection. The efficiency is decreased by the use of several DC-DC and DC-AC converters.

Our proposed PV fed bidirectional converter for EV vehicle is illustrated in Figure 1. This block diagram consists of PV panel, bidirectional converter, battery, and E-bike. The power from PV panel is irregular in nature, so when solar power generation is higher than the demand of the load, then the surplus energy is served to the battery station via bidirectional converter. Any time when the load demand goes beyond the instantaneous solar power generation, the shortfall of power demand is supplied by the station battery through the converter. When the absence of solar power, the battery power is transferred to the load through bidirectional converter. This study can be done for 1KW Solar charging station to charge electric bikes. P&O algorithm has been used in our system for implementing MPPT, due to its simplicity and less computational demands. Also, no prior knowledge of the PV system is necessary for the algorithm to work. The sun has been playing numerous roles in humane existence.

In this paper, section 2 consists of proposed circuit, section 3 contains simulation circuit and results discussion are carried out in section 4, finally section 5 consists of conclusion.

# A Novel Isolated DC-DC Multi-Level Flyback Converter for Multi-Level Inverter Application

Venugopal R  
Department of Electrical and  
Electronics Engineering  
Saranathan College of Engineering  
Trichy, India  
venugopalramadoss@gmail.com

Dr. Vijayalakshimi S  
Department of Electrical and  
Electronics Engineering  
Saranathan College of Engineering  
Trichy, India  
bksviji@gmail.com

Marimuthu M  
Department of Electrical and  
Electronics Engineering  
Saranathan College of Engineering  
Trichy, India  
marimuthueephd@gmail.com

Chandra Kishore M  
Department of Electrical and  
Electronics Engineering  
Saranathan College of Engineering  
Trichy, India  
chandra.083.ck@gmail.com

Mohammed Rifat Z  
Department of Electrical and  
Electronics Engineering  
Saranathan College of Engineering  
Trichy, India  
rifatzahir@gmail.com

Niresh Shankar P  
Department of Electrical and  
Electronics Engineering  
Saranathan College of Engineering  
Trichy, India  
niresshine@gmail.com

**Abstract --- The main theme of this paper is to present a high voltage gain dc-dc boost converter using flyback and multilevel concept. The proposed converter focuses on multilevel outputs with voltage multiplier cell. The input of the general dc-dc converters is either PV array or battery or fuel cell. The circuit is composed of diodes and capacitors which acts as voltage multiplier and also as a rectifier. The implemented multilevel flyback converter can be connected to an H-bridge forming a multilevel inverter. With the help of a single driven semiconductor switch namely MOSFET, the designed converter can produce a high voltage gain in continuous conduction mode. The proposed multilevel flyback converter has been simulated and verified with theoretical values. The results have been demonstrated in the report.**

**Keywords --- Flyback Converter - Multilevel Flyback - Voltage Multiplier (VM).**

## I. INTRODUCTION

Intergovernmental Panel on Climate Change, regularly access the latest climate science reports for every country which is established in 1988. The earth's average temperature is rising at an unprecedented rate, causing rapid warming and climate changes in the contrary of fossil fuels like coal and petrol. Since 1973, various acts like Air act which aims to control the levels of air pollution through measures of National Ambient Air Quality Standards (NAAQS) and Motor vehicles Act (1988) is aimed to address the vehicular traffic and transportation of hazardous wastes. In order to reduce consumption of fossil fuels, solar cars comes into picture. Hybrid Solar vehicles and Commercial Solar Vehicles are replacing the conventional auto Mobiles. The Solar Vehicles requires a wide range dc input voltages for its operation so the demand for DC-DC Converters are in the rise. Isolated converter which has high voltage is combined with VM cell is implemented in this paper.

The flyback converter is a power supply topology that uses mutually coupled inductor or transformer to store energy. The flyback converters are similar to the booster converters in architecture and performance. However, the primary winding of the transformer replaces inductor while

the secondary provides the output. In the flyback configuration, the primary and secondary windings of transformer are utilized as two separate inductors. The basic flyback converter uses a relatively small number of components. A switching device chops the input DC voltage and the energy in the primary is transferred to the secondary through the switching transformer. A diode in the secondary rectifies the voltage while the capacitor boosts and removes the ripple.

A voltage multiplier is an electrical circuit with combination of capacitor and diode that converts AC electrical power from a lower voltage to a higher DC voltage. Voltage multiplier cells are very much similar to rectifier. Usage in electrical and electronic application such as in microwave ovens, strong electric field coils for cathode-ray tubes, electrostatic and high voltage test equipment, etc. The DC output voltage of a rectifier is limited to the peak value of its sinusoidal input voltage. While combining multiple diodes and capacitors as VM cells, we can effectively multiply the DC output voltage for some odd or even multiples.

## II. DESIGN AND OPERATION OF MULTILEVEL FLYBACK CONVERTER

The overall block diagram for the need of high gain converter is shown in fig 1. The ultimatum of the proposed converter is to design a multilevel flyback converter using voltage multiplier cells. This interlinking of flyback and VM makes it possible to develop any number of levels of output just by adding combinations of diodes and capacitors. The main topology is to terminate the limitation of output.

The circuit is going to be operated in continuous conduction mode. Hence an inductor which act as a filter is connected parallel in the primary side of transformer. The inductor is used to limit high input voltage. A single semiconductor switch N-channel MOSFET has been used to control the pwm. Arduino micro controller has been used to provide gate pulse to the MOSFET. The switching frequency implemented is 50 kHz. The converter can operate in extremely high frequencies and so smaller value of inductor is enough. The circuit diagram has been shown in fig 2.

# Symmetric Multilevel Inverter Using DC-DC Zeta Converter

S.Srinithi  
Department of Electrical and  
Electronics Engineering  
Saranathan College of Engineering  
Trichy, India  
ssrinithiselvi@gmail.com

Dr.S.Vijayalakshmi  
Department of Electrical and  
Electronics Engineering  
Saranathan College of Engineering  
Trichy, India  
bksviji@gmail.com

M.Marimuthu  
Department of Electrical and  
Electronics Engineering  
Saranathan College of Engineering  
Trichy, India  
marimuthueeephd@gmail.com

B.Parathagan  
Department of Electrical and  
Electronics Engineering  
Saranathan College of Engineering  
Trichy, India  
parathagan-eee@sarathan.ac.in

**Abstract**— This paper presented is an attempt to suggest a high-gain Zeta converter with a voltage multiplier cell is fed with multilevel H-Bridge inverter. A perfect mixture of a slightly modified version of the regular Zeta converter and a voltage multiplier unit is the proposed circuit. The voltage addition of the suggested refitted zeta enhances the voltage gain by increasing n time of the multiplier unit. The proposed converter decreases the voltage issue over the transition, which concludes the superior output and the gain is improved without disrupting the primary circuit. In inverter to use minimum switches and get M-level output. The thorough study of the proposed converter with numerical analysis is now achieved with the help of MatLAB/Simulink.

**Keywords**— Multilevel Zeta (MLZ), Voltage-Multiplier unit (VMU), H-Bridge inverter.

## I. INTRODUCTION

DC to DC converters are the circuits that transform direct current sources to another voltage level by adjusting the duty cycle of the main circuit switches. These converters are commonly used in power distribution systems, dc motor drive applications and switched mode dc power system. Now a day it can be used in the maximum power point tracking in PV panel like a buck-boost converter. The Zeta converter design is identical to the SEPIC converter. The advantages of Zeta converter over the SEPIC converter are: 1. It has stable feedback loop even if the voltage range is wide it can provide a very good output voltage with relation. 2. Low output ripple, the output ripple of the Zeta converter is also lower than an equivalent SEPIC converter design. The multilevel Zeta converter is the combination of both conventional Zeta and the Voltage Multiplier Unit (VMU). The number of levels is easily added by the number of capacitors and diodes.

The excellence output voltage waveform depends on the number of inverter voltage level sand the number of output voltage level rises, the waveform become more sinusoidal [6]. To fulfill this requirement multilevel inverters are commonly used for their sinusoidal output wave. It is very challenging to get pure sine wave AC output with the use of

filter and it is very expensive, this can be easily achieved through multilevel inverter's (MLI) used. In MLI's are 1. Single source inverter 2.Multi source inverters. In our suggested circuit consists of single DC source only. This topology can be designed for both high and low power application. In the suggested scheme consists of two stages: the first is a multi-level DC-DC Zeta converter, which gives the DC output voltage value with the help of the VMU, get the N number of output levels, and the second one is the level circuit combine with H-Bridge inverter circuit, get the M level inverter outputs. Its actual details are seen in Fig.1.The M level stepped alternating current (AC) output voltage is easily obtained by only one DC source, with low number of power electronic components.

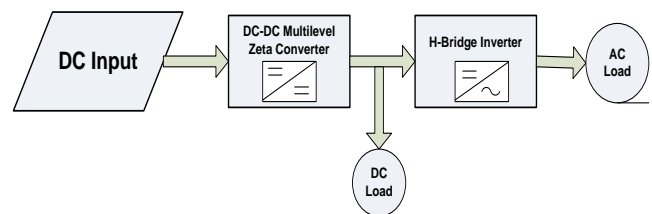

Fig. 1. Block diagram of proposed model

The main application of the MLI's are solar PV system, E-vehicles', auto mobiles, Fuel cells and Uninterrupted power supplies (UPS). Normal MLI's are complex structure need more input sources and stresses along the switches. In our suggested methodology simple in structure and used only one input source also reduced the switches stress. It is a symmetric MLI's DC source outputs are equal in magnitude.

## II. PROPOSED CONVERTER WITH INVERTER

The proposed model of DC-DC Zeta converter fed MLI's is illustrated in Fig. 2.

The Zeta converter is connected to the multiplier unit which is fed to the MLI via level switches. The DC-AC conversion is based on the Level circuit and the H-Bridge inverter.

# IMPLEMENTATION OF P & O ALGORITHM FOR MULTI LEVEL CASCADED- BOOST CONVERTER

Reka.J<sup>1</sup>, Vijayalakshmi.S<sup>2</sup>, Marimuthu.M<sup>3</sup>, Paranthagan.B<sup>4</sup>, Vijay.R<sup>5</sup>, Venugopal.R<sup>6</sup>

<sup>1</sup>Department of Electrical and Electronics Engineering, Cauvery College of Engineering, Trichy, Tamilnadu, India, Mail id: [reka.zenith@gmail.com](mailto:reka.zenith@gmail.com)

<sup>2</sup>Department of Electrical and Electronics Engineering, Saranathan College of Engineering, Trichy, Tamilnadu, India, Mail id: [bksvijji@gmail.com](mailto:bksvijji@gmail.com)

<sup>3</sup>Department of Electrical and Electronics Engineering, Saranathan College of Engineering, Trichy, Tamilnadu, India, Mail id: [marimuthueeephd@gmail.com](mailto:marimuthueeephd@gmail.com)

<sup>4</sup>Department of Electrical and Electronics Engineering, Saranathan College of Engineering, Trichy, Tamilnadu, India, Mail id: [paranthagan-eee@saranathan.ac.in](mailto:paranthagan-eee@saranathan.ac.in)

<sup>5</sup>Department of Electrical and Electronics Engineering, Saranathan College of Engineering, Trichy, Tamilnadu, India, Mail id: [vijay-eee@saranathan.ac.in](mailto:vijay-eee@saranathan.ac.in)

<sup>6</sup>Department of Electrical and Electronics Engineering, Saranathan College of Engineering, Trichy, Tamilnadu, India, Mail id: [satheesh-eee@saranathan.ac.in](mailto:satheesh-eee@saranathan.ac.in)

*Abstract*— Maximum power point (MPP) monitoring is an unavoidable feature of a solar (PV) array energy conversion system. Thus an attempt is made to implement the new multi-level cascaded boost converter for maximum power point tracking. MPPT plays a vital role in Photo Voltaic power system as they provides the maximum power output for PV System for different weather conditions and thereby gives improved array efficiency. The goal is accomplished here by implementing the Perturb & Observe MPPT algorithm, which also provides high voltage gain by the use of the proposed converter circuit. The MATLAB/SIMULINK is used for Testing and Implementing the required objective. The algorithms are implemented in m-file of MATLAB.

**Keywords:** *Photovoltaic Module, Multi Cascaded Boost Converter, MPPT Controller, Perturb and Observe method, PSIM.*

## I. INTRODUCTION

Environmental problems empower the world towards renewable energy production. The sunlight is the huge source of inexhaustible energy and the solar array are handled by the influence of the solar radiation, shading and temperature. Solar energy is effectively utilized by Photovoltaic System. The photovoltaic system is used to get the electrical energy from the PV system and restored in the battery

During the non-availability of solar energy, the battery storage system is used for supplying the power. The electric power obtain from solar panel is maximised using P&O algorithm by MPP Tracking. The DC-DC



# A Novel Non-isolated Single Switch Multilevel Cascaded DC–DC Boost Converter for Multilevel Inverter Application

M. Marimuthu<sup>1</sup> · S. Vijayalakshmi<sup>1</sup> · R. Shenbagalakshmi<sup>2</sup>

Received: 7 April 2020 / Revised: 9 June 2020 / Accepted: 22 July 2020  
© The Korean Institute of Electrical Engineers 2020

## Abstract

This paper presents a high gain non isolated Multilevel Cascaded Boost Converter (MCBC) for Electric vehicle applications. The proposed converter associates the basic cascaded Boost converter along with multilevel boost converter for boosting the voltages generated from different sources like solar energy, fuel cell and Battery. The multilevel boost converter is intended to be utilized as a dc link in which the high gain boosted voltage is provided to the multilevel inverter. By expending a single driven semiconductor switch and an inductor, the proposed converter is capable of producing high voltage gain with continuous input current and much higher step up conversion ratio. It not only allow to operate at much higher frequencies but aids in operating with a minimum duty cycle without a transformer. The proposed converter with five cascaded levels are simulated and is verified experimentally. The results thus illustrated go in concurrence with each other.

**Keywords** Boost converter · Multilevel cascaded boost converter · High voltage gain

## 1 Introduction

As per the United Nations report on climate change, the transportation sector majorly contributes towards the greenhouse gas emission. Even though India had made a Paris agreement in 2015 to reduce the emission, rigorous steps have to be taken in order to meet the unconditional commitments made in the Paris conference, 2015. The report further clarifies that the emission should be reduced by 55% lower than in 2018 so that the global warming would be limited to below 2 °C. The main reason for the increased emission from transport sector is due to the burning of petroleum products like petrol, diesel, CNG etc. It is also seen that after U.S. and China, India contributes more towards the emission

of Green House Gases leading to climate change. Hence there is a need for the modernized design of the Electric Vehicles which is one of the most promising alternatives for the conventional automobiles. The state of the art design of Electric vehicles leads to zero carbon emission vehicles which in turn results in “3Z” concept of zero poverty, zero unemployment and zero net carbon emission [1].

The hybrid electric vehicles and plug in hybrid electric vehicles are gaining popularity nowadays and a lot of researches are being conducted in order to develop a strong, robust and highly reliable hybrid energy storage scheme with immense power density, lesser price to weight ratio with longer life cycle. The Power Electronic Converters play a major role in controlling the power or current flow of such hybrid systems [2]. Since the hybrid electric vehicles use different power sources such as Battery, Fuel cells, Ultra capacitors and Ultrafly wheels, it is necessary that a robust and much more efficient dc–dc converter with high voltage conversion ratio is needed to boost up the available voltage from different sources into a desired regulated dc voltage. In [3] & [4] a highly efficient Boost converter is proposed in which a coupled inductor with three windings is manipulated so that high voltage gain is obtained and switching stress is also diminished. But the authors have not explicated the major limitations on the coupled inductors such as higher

✉ M. Marimuthu  
marimuthueeephd@gmail.com

S. Vijayalakshmi  
bksviji@gmail.com

R. Shenbagalakshmi  
Lakshmi\_amrith@yahoo.com

<sup>1</sup> Department of Electrical and Electronics Engineering,  
Saranathan College of Engineering, Trichy, Tamilnadu, India

<sup>2</sup> Department of Electrical and Electronics Engineering,  
SKN Sinhgad Institute of Technology & Science, Lonavala,  
Maharashtra, India

# Symmetric Multi-Level Boost Inverter with Single DC Source Using Reduced Number of Switches

Marikkannu MARIMUTHU\*, Subramanian VIJAYALAKSHMI

**Abstract:** In this paper a novel multilevel boost DC to DC converter with H-Bridge inverter circuit for single DC source is proposed. The proposed scheme has two stages: the first one is a multilevel boost converter which gives a multilevel dc output for a single dc source and the second level is a H-Bridge converter which converts multilevel DC to multilevel AC at required frequency. This DC-DC converter not only reduces the DC source but also reduces the switches, diodes and capacitors. This leads to decrease of the amount and the inverter space installation in order to increase the required output voltage by increasing the number of capacitors and diodes in the DC to DC converter. Comparison between the number of power switches for the suggested topology and other topologies in the recent literature is presented. Simulation results are conveyed through MatLAB/Simulink domain and the working of the suggested converter is realized.

**Keywords:** level circuit; multi-level boost converter (MBC); multi-level inverter (MLI); pulse width modulation (PWM); total harmonic distortion (THD)

## 1 INTRODUCTION

In order to achieve high boost ratios and excellent efficiency, there are several implemented boost topologies with transformer-less converter. In the conventional boost converter, the capacitor current is discontinuous resulting in larger capacitor size and EMI issues [1-5]. The MBC is the mixture of traditional boost DC-DC converter and the switched capacitor which works to provide different output voltages and a self-sustained voltage using one inductor, one switch,  $2M - 1$  ( $M$  - number of level) capacitors and  $2M - 1$  diodes for  $M$ \*MBC. It is a PWM based boost converter, where there are different required voltage levels with unidirectional current flow, and self-adjusting various level converters [6-11]. The main advantages of this converter are: it allows high switching frequency, a high gain beyond extreme duty cycle, continuous input current, and excludes transformer. Without modifying the main circuit, more levels of the converter should be achieved by adding diodes and capacitors. In order to achieve reduced switching losses, improved high voltage operation capability, less Electro Magnetic Interference (EMI), and high voltage gain, multilevel inverters are preferred.

To fulfill the demand of power rating and improved power quality with the reduced harmonic distortion, multilevel inverter is better than conventional inverter. Because the gate pulse used in the switches of MLI is high switching frequency PWM is recommended. Due to the easiness of the control and modularity the MLI is highly preferable to conventional inverter.

hard to get a pure sinusoidal AC output with the use of filters. It may increase overall cost of the system. Hence multilevel inverters are used in such applications. Multilevel inverters are classified into two major categories with single source and multiple sources. H-Bridge topology is used in multiple source inverters and the single source inverters use large capacitor banks. Fig. 1b shows the proposed MLI topology with Multi level Boost converter topology.

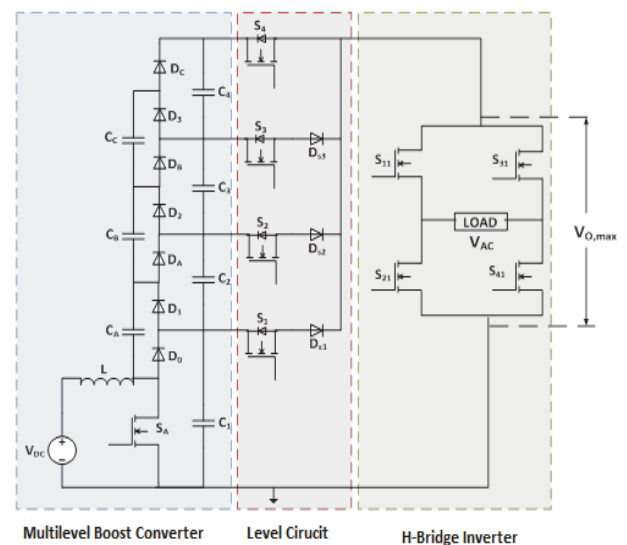

Figure 1b Proposed MLI topology with Multi boost DC to DC converter

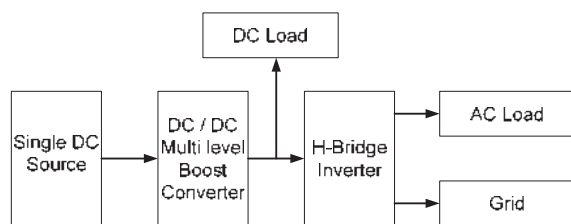

Figure 1a Proposed MLI block diagram

The AC power supply with high power quality and less THD is the primary requirement for the significance of High power. To meet this requirement multilevel inverters are normally used for their sinusoidal like output. In general, the renewable energy sources are DC. It is very

The minimum power renewable energy sources have no significance in high power applications, the dc boost converters are used to interface low power sources [20]. The proposed topology can be built for both low and high power application. This circuit consists of a single source multi-level boost converter whose output is the source of H-Bridge inverter. M-level inverter output can be obtained through this topology. The M-level stepped AC output voltage waveform can be obtained using one DC source, minimum number of switches, diodes and capacitors.

Applications of the extended MLI circuit are listed below: computer, telecom power supplies in remote areas supplied from solar panels, electric vehicles [22], uninterrupted power supplies [4] and renewable energy microgrid [21, 23].

# Design and Implementation of Multilevel Cascaded Boost converter fed Multilevel Inverter

Vijayalakshmi.S<sup>1</sup>, Marimuthu.M<sup>2</sup>, Paranthagan.B<sup>3</sup>, Dharneesh.K<sup>4</sup>, Manojkumar.P<sup>5</sup>, Kalaiarasan.G<sup>6</sup>, Surendran.R<sup>7</sup>

<sup>1</sup>Department of Electrical and Electronic Engineering, Saranathan College of Engineering, Trichy, Tamilnadu, India, Mail id: [bksviji@gmail.com](mailto:bksviji@gmail.com)

<sup>2</sup>Department of Electrical and Electronic Engineering, Saranathan College of Engineering, Trichy, Tamilnadu, India, Mail id: [marimuthueeephd@gmail.com](mailto:marimuthueeephd@gmail.com)

<sup>3</sup>Department of Electrical and Electronic Engineering, Saranathan College of Engineering, Trichy, Tamilnadu, India, Mail id: [paranthagan-eee@saranathan.ac.in](mailto:paranthagan-eee@saranathan.ac.in)

<sup>4</sup>Department of Electrical and Electronic Engineering, Saranathan College of Engineering, Trichy, Tamilnadu, India, Mail id: [dharneeshkalai@gmail.com](mailto:dharneeshkalai@gmail.com)

<sup>5</sup>Department of Electrical and Electronic Engineering, Saranathan College of Engineering, Trichy, Tamilnadu, India, Mail id: [manojkumar7622502@gmail.com](mailto:manojkumar7622502@gmail.com)

<sup>6</sup>Department of Electrical and Electronic Engineering, Saranathan College of Engineering, Trichy, Tamilnadu, India, Mail id: [kalaiaraangopal820@gmail.com](mailto:kalaiaraangopal820@gmail.com)

<sup>7</sup>Department of Electrical and Electronic Engineering, Saranathan College of Engineering, Trichy, Tamilnadu, India, Mail id: [surendran1819@gmail.com](mailto:surendran1819@gmail.com)

**Abstract**— Herein, a venture is contrived and executed with Multilevel Cascaded Boost converter fed Multilevel Inverter. This paper comes up with two grades, one specifies Multilevel Cascaded Boost Converter and other is Cascaded H-Bridge inverter. The Multilevel Cascaded Boost converter changes the single DC input into five stages and H-Bridge inverter converts DC output from converter into an AC. The output voltage stages of the converter can be enhanced by including capacitor and diode in the output terminal. This paper manages the machination and persistent state investigation of converter and inverter and the simulation have been performed exploiting MatLAB/Simulink.

**Keywords-** *Multilevel Converter; Cascaded Boost Converter; voltage multiplier cell; H-Bridge Inverter and Level Circuit.*

## I. INTRODUCTION

For the time being, the fossil fuels generate worry due to the fact that they are not persistent and will eventually shrink, became too expensive day by day and are environmentally damaging to reclaim. Besides the fossil fuels like coal, oil, natural gases are producing a risky effect and polluting the environment which are responsible for the climatic changes. Hence the renewable energy resources are becoming high attraction encompassed by the renewable energy resources. The photovoltaic power gaining the big league in future. Due to the captivating facts like pure, no charge of emission, and less maintenances. In many countries Photo Voltaic system are getting a rapid growth in domestic as well as in industrial applications. One big challenge is to afford an incorporation of DC low voltage PV module to utility grid. As a method to increase the available power a topology called Multilevel Converters are employed. This paper, a Novel topology called Multilevel Cascaded Boost Converter has been introduced to maximize the power obtained from the PV module.

# SINGLE PHASE MULTILEVEL INVERTER BASED ON A NOVEL SWITCHING SCHEME USING BUCK CONVERTER

**Paranthagan.B<sup>1</sup>, Vijayalakshmi.S<sup>2</sup>, Marimuthu.M<sup>3</sup>, Vijay.R<sup>4</sup>, Satheesh.R<sup>5</sup>**

<sup>1</sup>Department of Electrical and Electronics Engineering, Saranathan College of Engineering, Trichy, Tamilnadu, India, Mail id: [paranthagan-eee@saranathan.ac.in](mailto:paranthagan-eee@saranathan.ac.in)

<sup>2</sup>Department of Electrical and Electronics Engineering, Saranathan College of Engineering, Trichy, Tamilnadu, India, Mail id: [bksvijji@gmail.com](mailto:bksvijji@gmail.com)

<sup>3</sup>Department of Electrical and Electronics Engineering, Saranathan College of Engineering, Trichy, Tamilnadu, India, Mail id: [marimuthueeephd@gmail.com](mailto:marimuthueeephd@gmail.com)

<sup>4</sup>Department of Electrical and Electronics Engineering, Saranathan College of Engineering, Trichy, Tamilnadu, India, Mail id: [vijay-eee@saranathan.ac.in](mailto:vijay-eee@saranathan.ac.in)

<sup>5</sup>Department of Electrical and Electronics Engineering, Saranathan College of Engineering, Trichy, Tamilnadu, India, Mail id: [satheesh-eee@saranathan.ac.in](mailto:satheesh-eee@saranathan.ac.in)

**Abstract**— This paper presents a single phase multilevel inverter (MLI) based on a novel switching scheme. This new design produces a substantial decline in the count of power devices and capacitors required to implement a multilevel output battery-powered application. The proposed scheme has two stages namely, DC-DC converter and Inverter. Multilevel are achieved for the inverter by altering duty cycle of the DC-DC converter. In the MATLAB/SIMULINK setting, the proposed idea was implemented and the outcomes were validated.

**Keywords-** DC-DC Converter, Buck Converter, Multilevel Inverter, MATLAB

## I. INTRODUCTION

Due to the benefits of high power waveforms, less harmonic distortion, low common mode voltage, low switching operations, medium, high-voltage and high power capacity, multilevel inverters have become popular in recent years. Usually, an inverter is a system that uses certain electronic circuits to transform DC electrical power into AC type.

Buck converters can be highly efficient (often greater than 90%), making them helpful for tasks such as converting a computer's main (bulk) supply voltage (often 12 V) down to lower USB, DRAM and CPU voltages.. Buck converters are used in self-regulating power supplies and advanced telecom and data-com systems

Generally, a simple inverter provides 2 or 3 output voltage levels. But the multilevel inverter produces 5 levels of output voltage or more. As compared to a 2 stage inverter, it generates a stepped output voltage with reduced harmonic distortion. It offers higher levels of output voltage and power. The inverter requires a fixed dc voltage that can be extracted from the converter.

The multilevel inverter, correlated with lower output harmonics, provides high power capability. Their main downside is their complexity, which includes a large number of power devices and passive parts, as well as a very complex control circuit.



# JOURNAL OF REMOTE SENSING GIS & TECHNOLOGY

- HOME
- ABOUT
- LOGIN
- REGISTER
- CATEGORIES
- SEARCH
- CURRENT
- ARCHIVES
- ANNOUNCEMENTS

Home > Vol 6, No 3 (2020) > Vijayalakshmi

Open Access Subscription Access

## ISLAND MICRO-GRID HEALTH TRACKER SHOES

S. Vijayalakshmi, M. Marimuthu, S. K. Lakshmi, S. Megadharshini Megadharshini, K. Narmada Devi

### ABSTRACT

This paper presents an automated wearable technology that is being incorporated into an essential daily accessory, a shoe. This ensures round the clock monitoring of health and activity. Since being self-powered, accuracy and compatibility are the key features of the paper. Harvesting parasitic mechanical as well as thermal energy makes the shoe an island Pico grid that can function effectively.

### FULL TEXT:

PDF

### REFERENCES

Emaus A, Degerstrøm J, Wilsgaard T, Hansen

BH, Dieli- Conwright CM, Furberg AS, Pettersen SA, Andersen LB, Eggen AE, Bernstein L, Thune I. (2010), Does a variation in self-reported physical activity Reflect variation in objectively measured physical activity, resting heart rate, and physical fitness? Results from the Tromso study, Scand J Public Health, DOI: 10.1177/1403494810378919.

World Health Organization (2017), Global Strategy on Diet, Physical Activity, and Health, WHO, Available at: <http://www.who.int/dietphysicalactivity/pa/en> website.

Finkelstein EA, Haaland BA, Bilger M,Sahasranaman A, Sloan RA, Nang EE, Evenson K. R. (2016), Effectiveness of activity trackers with and without incentives to increase physical activity (TRIPPA): a randomized controlled trial, Lancet Diabetes Endocrinol, DOI: 10.1016/S2213-8587(16)30284-4.

Jakicic J M, Davis KK, Rogers RJ, King WC, Marcus MD, Helsel D, Rickman AD, Wahed AS, Belle SH (2016), Effect of wearable technology combined with lifestyle intervention on long-term weight loss: the IDEA randomized clinical trial, J Am Med Assoc, DOI: 10.1001/jama.2016.12858.

Susana Carneiro, Joana Silva, Bruno Aguiar, Tiago Rocha, Ines Sousa, Tiago Montanha and Jose Ribeiro (2015), “Accelerometer- Based Methods for Energy Expenditure using the Smartphone, 2015 IEEE International Symposium on Medical Measurements and Applications (MeMeA) Proceedings, DOI: 10.1109/MeMeA.2015.7145190.

Meethu Malu, Leah Findlater (2016), “Toward Accessible Health and Fitness Tracking for People with Mobility

### OPEN JOURNAL SYSTEMS

[Journal Help](#)

### USER

Username

Password

Remember me

### SUBSCRIPTION

[Login to verify subscription](#)

### NOTIFICATIONS

[View](#)  
[Subscribe](#)

### JOURNAL CONTENT

Search

Search Scope

### Browse

- [By Issue](#)
- [By Author](#)
- [By Title](#)
- [Other Journals](#)
- [Categories](#)

### FONT SIZE

### INFORMATION

- [For Readers](#)
- [For Authors](#)
- [For Librarians](#)

# Symmetric Multilevel Inverter Using DC-DC Zeta Converter

S.Srinithi  
Department of Electrical and  
Electronics Engineering  
Saranathan College of Engineering  
Trichy, India  
ssrinithiselvi@gmail.com

Dr.S.Vijayalakshmi  
Department of Electrical and  
Electronics Engineering  
Saranathan College of Engineering  
Trichy, India  
bksvijji@gmail.com

M.Marimuthu  
Department of Electrical and  
Electronics Engineering  
Saranathan College of Engineering  
Trichy, India  
marimuthueeephd@gmail.com

B.Parathagan  
Department of Electrical and  
Electronics Engineering  
Saranathan College of Engineering  
Trichy, India  
parathagan-eee@sarathan.ac.in

**Abstract**— This paper presented is an attempt to suggest a high-gain Zeta converter with a voltage multiplier cell is fed with multilevel H-Bridge inverter. A perfect mixture of a slightly modified version of the regular Zeta converter and a voltage multiplier unit is the proposed circuit. The voltage addition of the suggested refitted zeta enhances the voltage gain by increasing n time of the multiplier unit. The proposed converter decreases the voltage issue over the transition, which concludes the superior output and the gain is improved without disrupting the primary circuit. In inverter to use minimum switches and get M-level output. The thorough study of the proposed converter with numerical analysis is now achieved with the help of MatLAB/Simulink.

**Keywords**— Multilevel Zeta (MLZ), Voltage-Multiplier unit (VMU), H-Bridge inverter.

## I. INTRODUCTION

DC to DC converters are the circuits that transform direct current sources to another voltage level by adjusting the duty cycle of the main circuit switches. These converters are commonly used in power distribution systems, dc motor drive applications and switched mode dc power system. Now a day it can be used in the maximum power point tracking in PV panel like a buck-boost converter. The Zeta converter design is identical to the SEPIC converter. The advantages of Zeta converter over the SEPIC converter are: 1. It has stable feedback loop even if the voltage range is wide it can provide a very good output voltage with relation. 2. Low output ripple, the output ripple of the Zeta converter is also lower than an equivalent SEPIC converter design. The multilevel Zeta converter is the combination of both conventional Zeta and the Voltage Multiplier Unit (VMU). The number of levels is easily added by the number of capacitors and diodes.

The excellence output voltage waveform depends on the number of inverter voltage level sand the number of output voltage level rises, the waveform become more sinusoidal [6]. To fulfill this requirement multilevel inverters are commonly used for their sinusoidal output wave. It is very challenging to get pure sine wave AC output with the use of

filter and it is very expensive, this can be easily achieved through multilevel inverter's (MLI) used. In MLI's are 1. Single source inverter 2.Multi source inverters. In our suggested circuit consists of single DC source only. This topology can be designed for both high and low power application. In the suggested scheme consists of two stages: the first is a multi-level DC-DC Zeta converter, which gives the DC output voltage value with the help of the VMU, get the N number of output levels, and the second one is the level circuit combine with H-Bridge inverter circuit, get the M level inverter outputs. Its actual details are seen in Fig.1.The M level stepped alternating current (AC) output voltage is easily obtained by only one DC source, with low number of power electronic components.

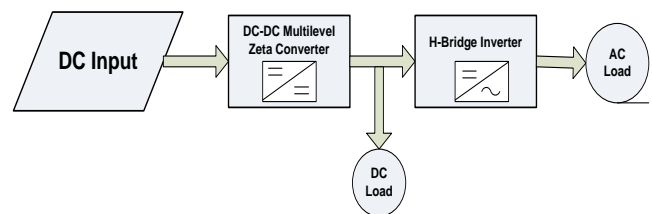

Fig. 1. Block diagram of proposed model

The main application of the MLI's are solar PV system, E-vehicles', auto mobiles, Fuel cells and Uninterrupted power supplies (UPS). Normal MLI's are complex structure need more input sources and stresses along the switches. In our suggested methodology simple in structure and used only one input source also reduced the switches stress. It is a symmetric MLI's DC source outputs are equal in magnitude.

## II. PROPOSED CONVERTER WITH INVERTER

The proposed model of DC-DC Zeta converter fed MLI's is illustrated in Fig. 2.

The Zeta converter is connected to the multiplier unit which is fed to the MLI via level switches. The DC-AC conversion is based on the Level circuit and the H-Bridge inverter.

# Analysis of PV Panel based Bidirectional Converter for Electric Vehicle

Vijayalakshmi S  
Department of EEE  
Saranathan college of Engineering,  
Trichy, India  
bksviji@gmail.com

Shivabalan N  
Department of EEE  
Saranathan college of Engineering,  
Trichy, India  
shivabalan1999@gmail.com

Thayananth.T  
Department of EEE  
Saranathan college of Engineering,  
Trichy, India

Marimuthu M  
Department of EEE  
Saranathan college of Engineering,  
Trichy, India  
marimuthueephd@gmail.com

Shathishkumar VK  
Department of EEE  
Saranathan college of Engineering  
Trichy, India  
shathishgokul@gmail.com

Venugopal. R  
Department of EEE  
Saranathan college of Engineering,  
Trichy, India  
venugopal-eee@saranathan.ac.in

Pravinraj T  
Department of EEE  
Saranathan college of Engineering  
Trichy, India  
pravinprince1122@gmail.com

**Abstract - This paper present an analysis of PV panel based Bidirectional converter for Electric vehicle charging. This system consists of solar cell battery, bidirectional dc -dc converter. A Battery is provided for supply power to dc motor during no sunlight condition. The bidirectional dc-dc converter is working in both charging and discharging the battery and can manage the flow of power in both the direction and hence excess energy from the PV panel can be stored in battery. MPPT controller extract maximum power from the PV module under the impact of varying irradiance and varying the load conditions. Model Performance evaluation and analysis has been done through MatLAB/Simulink**

**Keywords : PV panel, Bidirectional Converter, battery, Maximum Power Point Tracking (MPPT).**

## I. INTRODUCTION

Solar energy becomes the most challenging energy sources. In fact, a lot of domestic & industrial or commercial applications use solar energy. Solar energy is a key source to reduce Co2 emissions. On our country, ICE (Internal combustion Engines) are a major source of pollution, hence Electric vehicles become the promising solution. For many reasons taking into account, environmental and cost considerations, renewable energy sources such as solar energy is preferable to charge plug-in electric vehicles. In India, mostly IC engines where used for the transportation. In order to reduce environmental pollution and climatic change and increasing price of fossil fuels, Indian government encourages to promotes more and more electrical vehicles (EV). The Indian government set a target to accelerate the adoption of Electrical vehicles to reduce pollution and many other advantages like high torque and easy speed control. However, all IC engines have to be replaced by an energy storage battery with the help of suitable converter.

In [1] the authors propose an AC charging station with second life Li-ion battery, integrating solar PV, and wind energy. This station is grid connected which allows the export or import energy depending on the utilization. The authors in [2], [4] a control strategy of a multi-port, grid connected, direct DC PV charging station was proposed, the source of energy here can be either PV panels or AC grid, the transfer of energy from AC grid is bidirectional, hence, PV

energy can be injected on AC grid. These two topologies use many converters, which reduce efficiency. In [5] a charging strategy is proposed to minimize the energy cost, the charging time is divided into intervals to minimize the peak consumption of a fleet of EVs during day time. The charging station in this case is grid connected; in addition, the topology was not given.

The effect of fast charging EVs on the AC grid was investigated in [8]: the charging station in [8] is a DC fast charging, and only the grid is used as energy source. The energy source is not renewable and the efficiency is decreased by using two converters. Four possible architectures for a solar EV charger are proposed and compared in [9], these configurations are also grid connected, two possible choices for interconnection to the AC grid: AC inter-connection or DC inter-connection. The efficiency is decreased by the use of several DC-DC and DC-AC converters.

Our proposed PV fed bidirectional converter for EV vehicle is illustrated in Figure 1. This block diagram consists of PV panel, bidirectional converter, battery, and E-bike. The power from PV panel is irregular in nature, so when solar power generation is higher than the demand of the load, then the surplus energy is served to the battery station via bidirectional converter. Any time when the load demand goes beyond the instantaneous solar power generation, the shortfall of power demand is supplied by the station battery through the converter. When the absence of solar power, the battery power is transferred to the load through bidirectional converter. This study can be done for 1KW Solar charging station to charge electric bikes. P&O algorithm has been used in our system for implementing MPPT, due to its simplicity and less computational demands. Also, no prior knowledge of the PV system is necessary for the algorithm to work. The sun has been playing numerous roles in humane existence.

In this paper, section 2 consists of proposed circuit, section 3 contains simulation circuit and results discussion are carried out in section 4, finally section 5 consists of conclusion.

# A Novel Isolated DC-DC Multi-Level Flyback Converter for Multi-Level Inverter Application

Venugopal R

Department of Electrical and  
Electronics Engineering  
Saranathan College of Engineering  
Trichy, India  
venugopalramadoss@gmail.com

Dr. Vijayalakshimi S

Department of Electrical and  
Electronics Engineering  
Saranathan College of Engineering  
Trichy, India  
bksviji@gmail.com

Marimuthu M

Department of Electrical and  
Electronics Engineering  
Saranathan College of Engineering  
Trichy, India  
marimuthueeephd@gmail.com

Chandra Kishore M

Department of Electrical and  
Electronics Engineering  
Saranathan College of Engineering  
Trichy, India  
chandra.083.ck@gmail.com

Mohammed Rifat Z

Department of Electrical and  
Electronics Engineering  
Saranathan College of Engineering  
Trichy, India  
rifatzahir@gmail.com

Niresh Shankar P

Department of Electrical and  
Electronics Engineering  
Saranathan College of Engineering  
Trichy, India  
niresshine@gmail.com

**Abstract --- The main theme of this paper is to present a high voltage gain dc-dc boost converter using flyback and multilevel concept. The proposed converter focuses on multilevel outputs with voltage multiplier cell. The input of the general dc-dc converters is either PV array or battery or fuel cell. The circuit is composed of diodes and capacitors which acts as voltage multiplier and also as a rectifier. The implemented multilevel flyback converter can be connected to an H-bridge forming a multilevel inverter. With the help of a single driven semiconductor switch namely MOSFET, the designed converter can produce a high voltage gain in continuous conduction mode. The proposed multilevel flyback converter has been simulated and verified with theoretical values. The results have been demonstrated in the report.**

**Keywords --- Flyback Converter - Multilevel Flyback - Voltage Multiplier (VM).**

## I. INTRODUCTION

Intergovernmental Panel on Climate Change, regularly access the latest climate science reports for every country which is established in 1988. The earth's average temperature is rising at an unprecedented rate, causing rapid warming and climate changes in the contrary of fossil fuels like coal and petrol. Since 1973, various acts like Air act which aims to control the levels of air pollution through measures of National Ambient Air Quality Standards (NAAQS) and Motor vehicles Act (1988) is aimed to address the vehicular traffic and transportation of hazardous wastes. In order to reduce consumption of fossil fuels, solar cars comes into picture. Hybrid Solar vehicles and Commercial Solar Vehicles are replacing the conventional auto Mobiles. The Solar Vehicles requires a wide range dc input voltages for its operation so the demand for DC-DC Converters are in the rise. Isolated converter which has high voltage is combined with VM cell is implemented in this paper.

The flyback converter is a power supply topology that uses mutually coupled inductor or transformer to store energy. The flyback converters are similar to the booster converters in architecture and performance. However, the primary winding of the transformer replaces inductor while

the secondary provides the output. In the flyback configuration, the primary and secondary windings of transformer are utilized as two separate inductors. The basic flyback converter uses a relatively small number of components. A switching device chops the input DC voltage and the energy in the primary is transferred to the secondary through the switching transformer. A diode in the secondary rectifies the voltage while the capacitor boosts and removes the ripple.

A voltage multiplier is an electrical circuit with combination of capacitor and diode that converts AC electrical power from a lower voltage to a higher DC voltage. Voltage multiplier cells are very much similar to rectifier. Usage in electrical and electronic application such as in microwave ovens, strong electric field coils for cathode-ray tubes, electrostatic and high voltage test equipment, etc. The DC output voltage of a rectifier is limited to the peak value of its sinusoidal input voltage. While combining multiple diodes and capacitors as VM cells, we can effectively multiply the DC output voltage for some odd or even multiples.

## II. DESIGN AND OPERATION OF MULTILEVEL FLYBACK CONVERTER

The overall block diagram for the need of high gain converter is shown in fig 1. The ultimatum of the proposed converter is to design a multilevel flyback converter using voltage multiplier cells. This interlinking of flyback and VM makes it possible to develop any number of levels of output just by adding combinations of diodes and capacitors. The main topology is to terminate the limitation of output.

The circuit is going to be operated in continuous conduction mode. Hence an inductor which act as a filter is connected parallel in the primary side of transformer. The inductor is used to limit high input voltage. A single semiconductor switch N-channel MOSFET has been used to control the pwm. Arduino micro controller has been used to provide gate pulse to the MOSFET. The switching frequency implemented is 50 kHz. The converter can operate in extremely high frequencies and so smaller value of inductor is enough. The circuit diagram has been shown in fig 2.

# Non-isolated Multilevel Zeta Converter for MLI Application

Proceedings of International Conference on Power Electronics and Renewable Energy Systems pp 21-30 | Cite as

- Marikannu Marimuthu (1)
- Subramanian Vijayalakshmi (1)
- B. Paranthagan (2)
- R. Venugopal (3)
- S. Srinithi (4)
- B. Yuvaraj (5)
- R. Soundarajan (5)
- S. K. Vasantha Kumar (5)

1. Department of Electrical and Electronics Engineering, Saranathan College of Engineering, , Trichy, India

2. Associate Professor, Department of Electrical and Electronics Engineering, Saranathan College of Engineering, , Trichy, India

3. Assistant Professor, Department of Electrical and Electronics Engineering, Saranathan College of Engineering, , Trichy, India

4. PG Scholar, Department of Electrical and Electronics Engineering, Saranathan College of Engineering, , Trichy, India

5. UG Student, Department of Electrical and Electronics Engineering, Saranathan College of Engineering, , Trichy, India

Conference paper

First Online: 22 November 2021

- 64 Downloads

Part of the [Lecture Notes in Electrical Engineering](#) book series (LNEE, volume 795)

## Abstract

A new multilevel zeta converter which converts fixed DC voltage to multilevel DC output voltage is discussed in this paper. Proposed converter has stable voltage feedback capacity and produces high gain output voltages with less input current. Voltage supplied by the PV panel or the fuel cell is at an output of a low voltage. These output voltages can be interfaced with standalone (or) grid connected inverter system by employing the proposed converter. By using a single transistor with the multilevel capacitor geometric structure, the proposed converter is able to generate an output voltage that is much higher and has ripple free output current with a higher step-up conversion ratio. It allows for operation at much higher frequencies for a much longer



## **Performance Comparison of L-UPQC and R-UPQC with FUZZY logic Controller for Power Quality Improvement**

Ananthan Nagarajan<sup>1\*</sup>, P.Sivachandran<sup>2</sup>, M.V.Suganyadevi<sup>3</sup>

<sup>1</sup>Ph.D Scholar, Anna University, Guindy, Chennai,India

<sup>2</sup>Professor, Department of EEE, Vel Tech Multi Tech Dr. Rangarajan Dr. Sakunthala Engineering College, Chennai,India

<sup>3</sup> Associate Professor, Department of EEE, Saranathan College of Engineering, Trichy, India

**Abstract :** In the modern power system, the usage of power electronic loads was statically high and it behaves as non-linear load. This load causes the serious voltage distortion and power quality issues on the transmission and distribution system by injecting the harmonics. Usually active power filters are used to regulate this problem. Unified power quality conditioner is the combination of series and shunt active power filters. It not only eliminates the harmonics, also it treats all type of voltage and current fluxuations and compensate the reactive power in distribution system. In this paper new topology of unified power quality conditioner with different control strategy was introduced to rectify the power quality issues and increase the strength of power quality. UPQC concern feedback system with FUZZY logic controllers was used to improve the performance of UPQC and compare the results using MAT LAB/SIMULINK.

**Index Terms :** L-UPQC, R-UPQC, Active Power Filters, Power Quality.

### **I. Introduction**

An electric power system is a network of electrical components deployed to supply, transfer, store, and use electric power. An example of an electric power system is the grid that provides power to an extended area. An electrical grid power system can be broadly divided into the generators that supply the power, the transmission system that carries the power from the generating centres to the load centres, and the distribution system that feeds the power to nearby homes and industries[1]. Compared to generation and transmission we have huge power quality issues on distribution system. The impacts of power quality problems are voltage surges/spikes, voltage dips, under voltage, high-voltage spikes, frequency variation, power sag, electrical line noise, brownouts, blackouts, very short interruptions, long interruptions, voltage swell, and harmonic distortion.[2].

Now a day we frequently using variety of sensitive loads such as computer, led television, home automation, etc. Due to poor power quality such equipment may failure or less life span. To diagnose this

# GSM Based Automatic Energy Meter Reading System

<sup>[1]</sup> M. Aravinth, <sup>[2]</sup> A. Francis Adaikala Raj, <sup>[3]</sup> D. Hariraju, <sup>[4]</sup> D. Hariharan, <sup>[5]</sup> Dr. M.V. Suganya Devi  
<sup>[1]</sup> <sup>[2]</sup> <sup>[3]</sup> <sup>[4]</sup> UG Scholar, Department of EEE, Saranathan College of Engineering Trichy, India  
<sup>[5]</sup> Associate Professor, Department of EEE, Saranathan College of Engineering, Trichy, India

**Abstract:** This data presents the implementation of a simple low cost wireless Global System for Mobile (GSM) energy meter and imply the message back to the end user via GSM modem. A GSM occupying wireless communication module is synchronized with electronic energy meter of each entity to have far-off connection over the usage of electricity. This paper is useful to glean meter readings. The employed man power don't need regular visitation to each end user for the consumed data collection and to distribute the check slip. A phone with a GSM receiver at the other end, which contains the database acts as the billing sector. The complete monthly routine and due check is conveyed back after processing these data.

**Keywords—** GSM, Wireless, Energy meter.

## I. INTRODUCTION

Electrical power plays a vital role for the human survival and evolution. Apart from the efforts to meet rising interest, automation in the energy usage is also necessary to enhance people's livelihood. At this moment the employee goes to premises and draft the reading of the meter manually. An energy meter is a device which is used to measure the energy consumption of any residence or industrial establishment. In conventional energy metering system we measure consumption of energy. The company hire employees who visit each premises and draft the reading manually.

This is a sluggish and laborious work to be done. In skyscrapers and luxurious housing apartments and areas, traditional meter and the usage drafting process is outdated. There may be a chance for lacking checks, absence of consumer etc. Even though, these traditional meters cause problems they still persist. For a system which will provide the check in user's phone through the wireless GSM module will be more suitable to the current generation. The ample propagation of wireless communication gives out the new possibilities for the next generation Automatic Meter Reading (AMR) whose goal is to collect the energy usage from the meter automatically. AMR have new features that help to reduce the cost of usage to consumer and the man power provided by the utility provider is reduced. Here a new approach of electronic metering of energy meter is introduced in this script will automatically detect the energy usage and record these reading continuously, and then send it to the billing sector through the GSM module. Convincingly after processing the acquired data the check is generated and send to the end user as a message (SMS).

## II. LITERATURE SURVEY

[1] S. Arun, Dr. Sidappa Naidu "Design and implementation of Automatic meter Reading System using GSM, ZIGBEE through GPRS". This paper gives an implementation technology for a wireless automatic meter reading system incorporating widely used GSM and ZIGBEE. Using GSM WAMRS provides a cost-effective, wireless, the WAMRS sends information of utility usage, power quality and outage alarm to utility usage.

[2] B. Abdul Rahim, O. Homa Kesav "Automated wireless meter reading system for monitoring and controlling power. The ARM7LPC2148" microcontroller module gets the data from the energy meter and performs necessary operations like breaking the circuit through relay control unit and the information is send to mobile phone through GSM.

[3] Shradda Male, Pallavi Vethekar, kavitha More, Prof. V.K. Bhusari "Smart Wireless Electronic energy meter reading using embedded technology". In this Paper they presented that the metering IC gives the output in the form of pulses which are counted using the timer in PIC microcontroller. These pulses are identified by automatic voltage regulator. For reading the data from the IC, the microcontroller is programmed using software interfacing.

[4] E. Moni Silviya, K. Meena Vinodhini, Salai Thillai Thilagam.J "GSM based Automatic energy meter reading with instant billing". In This paper IR sensor is used to measure the current consumption unit. The IR transmitter is used in the rotating unit of the energy meter. By getting the number of rotation current consumption can be taken.

# Prediction of Voltage Stability Margin using SVR for the Real Time Environment

Dr. M. V. Suganya Devi <sup>1</sup>,  
Associate Professor,  
Saranathan College of Engineering,  
Panjappur, Trichy-12,

P. Pavithraa<sup>2</sup>, A. Yuvarani<sup>2</sup>,  
K. G. PavithraDevi<sup>2</sup>,  
UG Scholar,  
Saranathan College of Engineering,  
Panjappur, Trichy-12

**Abstract:** This paper investigates the use of reactive power reserves (RPR) as an indicator to estimate voltage stability margin (VSM) in an online environment. The methodology relies upon the relationship between system-wide RPRs and VSM. Support vector regression model(SVM) are utilized in order to express how variations in RPRs can be transformed into direct information about VSM. Data regarding RPRs and system VSM are obtained through an offline voltage stability assessment (VSA) and stored in a database for further SVR development. Different load increase directions and a comprehensive list of contingencies are considered to account for uncertainty present in real-time operations. Once properly designed and validated, the SVRs are ready to be used in the online environment. The methodology is tested on the IEEE 30-bus system and a real Indian bus system containing 181 buses. Preliminary results show that SVRs can be successfully employed in online VSM estimation.

**Keywords:** Support vector regression, Voltage stability margin, Regression, Reactive power, CPF

## NOMENCLATURE:

Y - dependent variable (or response).

X - independent variable (or regressor) in the SVR.

$\beta$  - regression coefficient.

$\epsilon$  -  $i$ th residual.

n - Number of samples.

$\lambda$  - Load Increase Parameter.

## I INTRODUCTION

In the world, number of times condition of blackout occurs, by which a lot of consumers gets affected. Some of major blackouts from all over the world in the last few decades include a massive breakdown in India on 30-31/July/2012, by which 7 states and approx.620 millions peoples affected. This is called biggest ever power failure in the world. Another one is fault in transmission line occurs at Uttar Pradesh state in India on 2/Jan/2001, by which 230 millions peoples affected. On 1/Nov/2014 Bangladesh suffered nationwide power outage for almost 10hrs and almost 150 million peoples affected. On 26/Jan/2015 over 80% of Pakistan went power off due some technical fault at power station in sindh, by which 140 million peoples affected. A transmission system failure occurs in java-Bali,

Indonesia on 18/Aug/2005, approx.100 million peoples get affected [1].

At any point of time, a power system operating condition should be stable, meeting various operational criteria, and it should also be protected in the event of any realistic emergency. Power system stability may be defined as that property of a power system that enable it to remain in a state of operating equilibrium under normal operating conditions and to regain an acceptable state of equilibrium after being subjected to disturbances. Present day power systems are being operated closer to their stability limits due to economic and environmental constraints[2]. Maintaining a stable and secure operation of a power system is therefore a very important and challenging issue. In order to improve reactive power management, the North American Electric Reliability Corporation (NERC) has issued several reliability standards related to real-time reactive power reserve monitoring and voltage control [3]–[4]. Real-time reactive power reserve monitoring has also been identified as one of the recommended actions to reduce the likelihood of future system blackouts [5]. The inherent relationship between reactive power support and voltage stability is the general argument used to support these practices.

Despite the development of new standards and practices, re- active power monitoring systems are not a novelty for some North American and European utilities. Bonneville Power Administration (BPA) developed an online reactive power monitoring system that monitors the available RPRs at some generators and SVCs for different areas of their system [6]. At low levels of RPR, an alarming system will indicate that corrective actions should be taken in order to move the system to a safer operating condition. Other utilities rely on the monitored amounts of RPRs to implement special protection schemes against voltage collapse [7]–[8]. Real-time reactive power reserve monitoring has also been identified as one of the recommended actions to reduce the likelihood of future system blackouts. The relationship between reactive power support and voltage stability is used to support these practices. However, monitoring RPR alone cannot provide quantitative information of, how far a system might be from a voltage collapse. Therefore, the



# Hybrid Renewable Energy Parameter Monitoring and Control of Smart Street Light Using IoT

S MURUGESAN, M.V.SUGANYADEVI

**Abstract:** In day today life, the whole world electricity wastage is the biggest problem in society. The power wastage of street light is the major problem in rural areas and remote location. The objective of our current work is to design IoT based power generation and management of smart street light using hybrid renewable solar and wind energy system. This proposed work DC-DC converter which is used to boost the output power from the sources and it transmits it to the street light. In our proposed work, we use esp8266 modem can monitor the voltage and current hybrid renewable energy system. All this parameters are controlled and monitored through IOT blynk server from the base station. Using the IoT Technology for supervising wind and solar power generation can effectively improve the performance of smart street light monitoring and control system. IoT is employed to feed the information into the thinkspeak cloud in order that it eases the storage of data and may be accessed at any point of your time throughout the energy generational process. This project can do high efficiency power and additionally the peak demand has been satisfied.

**Index Terms:** IoT, DC-DC converter, ESP8266, LM 35, Thingspeak, Blynk App, Wind and Solar system.

## 1 INTRODUCTION

The street lights consume nearly 30-40% of the whole city power consumption. Thus, system able to expeditiously manage the lighting is completely sensible. the biggest expenses of a city are primarily attributable to street lights. a smart street light may be used to cut the municipal waste up to 50- 70th. An intelligent lighting system primarily adjusts the light supported the method it is used. The project is especially used to track the usage of light using sensors and it's the one exploitation the wireless system management to regulate to manage} the energy consumption and uses reduction measures through power acquisition and control. Whenever the required the sunshine are made ON/OFF remotely and also the same data can be accessed by internet, which may be created ON/OFF using IoT The intelligent street light controller should be installed on the light pole that consists of microcontroller together with various sensing element and wireless module. The captured information cane transferred to base station wherever the energy gets stored using wireless technology to observe the smart system. It can be operated remotely via internet server or IoT blynk app. The proposed system was designed by microcontroller, IoT modem and relay driver circuit which interface the smart LED lamp. This also include the nodemcu devices where the authorized person can interact with cloud or Android IoT app to control the Street light from any place with the help of IoT. This technology has been developed to reduce the power consumption of lighting system

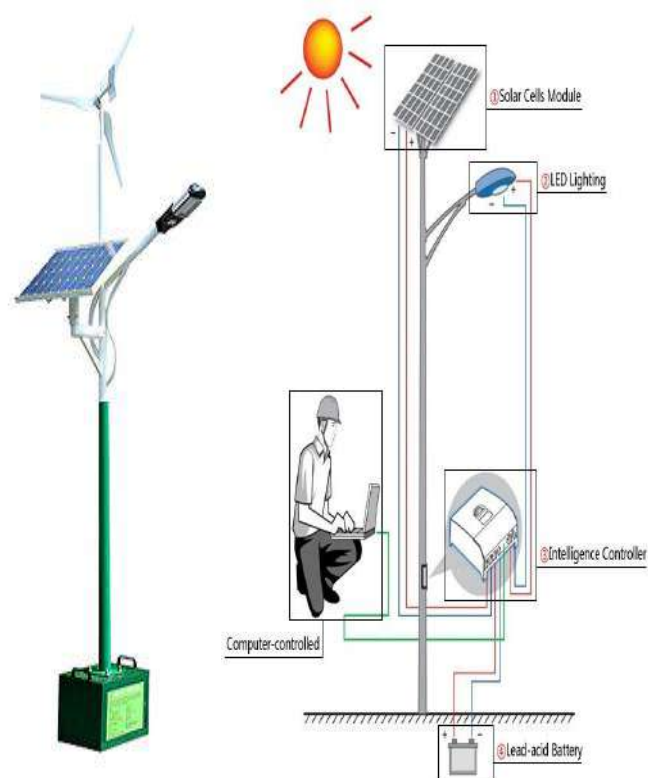

**Fig.1 shows the design of smart street light system**

The centralized IoT network monitoring lights ON/OFF control are the power efficient and low cost approach for saving electricity. This technique cuts down the cost of typical system by 50-60% that improves the electricity of the country and saves an enormous amount of investment as it may be utilized in helpful concepts.



# Detection and classification of multi-complex power quality events in a smart grid using Hilbert–Huang transform and support vector machine

C. K. Hemapriya<sup>1</sup> · M. V. Suganyadevi<sup>1</sup> · C. Krishnakumar<sup>1</sup>Received: 6 December 2019 / Accepted: 24 March 2020 / Published online: 6 April 2020  
© Springer-Verlag GmbH Germany, part of Springer Nature 2020

## Abstract

This article examines the potential ability of a chosen Hilbert–Huang transform (HHT) in detecting and identifying a multi-complex electric power quality events (PQE) signal in smart grid power systems under various noise situations. HHT is an active signal processing technique, comprising the units of empirical mode decomposition (EMD) and Hilbert spectral analysis (HSA) to detect the non-stationary electric signals. The function of EMD is to detect and decompose the non-stationary electric signal in different scales of frequency modules ranging from maximum to minimum values, and thereby the attained signals are characterized as intrinsic mode functions (IMFs). HSA details the IMF signals individually to produce a unique Hilbert spectrum which carries the information of original signal. By observing the instant time-varying deviations of frequency and amplitude of the resultant signals, it is possible to categorize the disturbing signals from the original signal. The discussed slots of work is simulated under MATLAB environment, and the results report that the HHT successfully detects the single PQE, complex PQE and multi-complex PQE signals under 25 dB, 50 dB and without noise situations. The outcomes of HHT technique are compared with other transforms such as S-transform and wavelet transform to highlight superior qualities of HHT. The identified PQE signals from HHT are classified using support vector machine to improve its classification accuracy. It is wiser to disclose that the proposed system with inbuilt monitoring and identification of PQE signals will suit present smart grid system.

**Keywords** Empirical mode decomposition · Hilbert–Huang transform · Intrinsic mode functions · Power quality · Support vector machine · S-transform · Wavelet transform

## Abbreviations

ANN	Artificial neural network
ARTMAP	Adaptive resonance theory map
CWT	Continuous wavelet transform
DFT	Discrete Fourier transform
DOST	Discrete orthogonal S-transform
ELM	Extreme learning machine
EMD	Empirical mode decomposition
FFT	Fast Fourier transform
FNN	Feed-forward neural network
FPGA	Field programmable gate array

FT	Fourier transform
FTTT	Fast time–time transform
GA	Genetic algorithm
HHT	Hilbert–Huang transform
HST	Hyperbolic S-transform
IMF	Intrinsic mode functions
MNN	Modular neural network
NM	Not mentioned
NN	Neural network
PDF	Probability density functions
PNN	Probabilistic neural network
PQ	Power quality
PQE	Power quality event
PSO	Particle swarm optimization
RBDDT	Rule-based decision tree
RMS	Root mean square
RVM	Relevance vector machine
SAX	Symbolic aggregate approximation

✉ C. K. Hemapriya  
hemapriya.ck@gmail.com

<sup>1</sup> Department of Electrical and Electronics Engineering,  
Saranathan College of Engineering, Tiruchchirappalli,  
Tamilnadu, India

# USING SOFT COMPUTING TECHNIQUES THE MEASUREMENT OF VOLTAGE STABILITY OF THE POWER SYSTEM

**Dr. M. V. Suganyadevi**

Associate Professor, Department of Electrical and Electronics Engineering,  
Saranathan College of Engineering, Trichy- 12, India

**Perumal Raja. S, Pradeep. P, M. Vasanth, M. Viswanathan**

UG Scholar, Department of Electrical and Electronics Engineering,  
Saranathan College of Engineering, Trichy- 12, India

## ABSTRACT

*In this paper we propose measurement based voltage stability using different soft computing technique for estimating the output data of the voltage stability margin. In the conventional method of monitoring of the voltage stability limits of the power system through different lines to busses consumes more time to get the desired values for the analysis. In this method we use some of the optimization techniques such as Support Vector Regression (SVR), Artificial Neural network (ANN) to obtain more specific results in a limited time frame. We use IEEE 30-bus system for testing.*

**Keywords:** Voltage stability assessment, PSAT, CPF, ANN, ANFIS, SVR, Voltage stability limits

**Cite this Article:** Dr. M. V. Suganyadevi, Perumal Raja. S, Pradeep. P, M. Vasanth and M. Viswanathan, Using Soft Computing Techniques the Measurement of Voltage Stability of the Power System, *International Journal of Electrical Engineering & Technology*, 11(3), 2020, pp. 32-39.

<http://www.iaeme.com/IJEET/issues.asp?JType=IJEET&VType=11&IType=3>

---

## 1. INTRODUCTION

Electric power system has become more complex and larger. Power system components operate very much closer to their stability limits, with the small security margin. In case of occurrence of any type of fault or disturbance in generator, transmission line, transformer can lead to voltage instability [1]. These changes of the operating limit of the electrical parameter increases such that they cannot be controlled by corrective devices used in control system parameter. When power quality problems occurring in a system causing decrease in voltage level of the system or sag, gradual increase or swell that occurs in the system under heavily loaded system. Some well-known example of voltage instability accidents such as German, Sweden, Belgium, Japan, USA [2] [3].

## ADVANCED ENERGY METER BASED ON INTERNET OF THINGS

**Dr.M.V.Suganyadevi\***, **P.Priyadharshani<sup>1</sup>**, **S.Selvashanthini<sup>2</sup>**, **S.Suruthi<sup>3</sup>**, **M.Swarnasri<sup>4</sup>**

<sup>1,2,3,4</sup> UG Student, Department of EEE & Saranathan College of Engineering, Trichy, India

\* Associate Professor, Department of EEE & Saranathan College of Engineering, Trichy, India,  
suganyadevi-eee@saranathan.ac.in

**Abstract** - Today the world is developed with lots and lots of technology in all the aspects. As the people survive in this technological world they are very much dependent on the electrical and electronic equipments for their day today life. And, day by day the population growth is also drastically increasing. These both issues make the usage of power more. As the usage of power is more the electricity reading is complex which may causes human errors while notifying the readings. Due to this the energy crisis and energy theft occurs. To eradicate these problems an advanced energy meter using internet of things (IoT) is implemented. The features of this energy meter are whenever the over voltage arises the indication is provided in the form of alarm to the respective consumers so as to limit the usage of power. This provides the day today power reading that is voltage and current used by the consumers in regular time intervals. And this device provides the electricity theft indication .Additional feature is that, if the consumer who has not paid the electricity payment the disconnection of the service is done and the service is resumed in case when the payment is done from the utility side. This paper deals with these entire concepts which are mentioned above in a detailed manner. The main concept of advanced energy meter is that it is a low cost and effective energy meter than a normal energy meter which provides the over voltage indication, the consumed power in a regular intervals, indication of electricity theft to the respective consumers by using a microcontroller and a Wi-Fi module along with IoT.

**Key Words:** Internet of Things, Advanced energy meter, microcontroller, Wi-Fi module

### I. INTRODUCTION

Today the world is developed with multiple technologies one such is wireless technology. This is helpful in automatic devices and reduces the human work with the help of microcontrollers. This is implemented in the advanced energy meter.

In case of existing energy meter requires human power to note down the data and for calculating the power. And calculation of reading sometimes gives error data due to human error while calculating.

As the users are increased day by day this creates problem in maintaining and regulating the system periodically. And the operator has to do calculation and billing manually for each and every consumer. If the consumer is not in their residence when the operator comes to take reading it becomes difficult situation for the operator. These all makes hectic situation for operator. And also it is a time consuming process.

And there comes a difficult situation for an operator even during weather condition is bad and during natural calamities. And if the energy is theft the consumers are not notified about that problem. But the billing becomes expensive without using more power.

These issues are limited in wireless technology. This does not need any human intervention like operators. In case of wired system there is a need a regular maintenance as there is lot of connection and also cost high.

In case of wireless technology the maintenance is easy and it is convenient for users. In the proposed system wireless technology based of Internet of Things (IoT) is done.

## Photovoltaic based Induction motor speed control Using SEPIC converter

S.Gomathi\*, Dr.M.V.Suganyadevi<sup>1</sup>, Dr.A.Deepak<sup>2</sup>, M.Nithya<sup>3</sup>, R.Vivitha<sup>4</sup>

\*Assistant Professor , St. Joseph's Institute of Technology, Chennai.

<sup>1</sup>Associate Professor, Saranathan College of Engineering, Trichy.

<sup>2</sup>EM -Design Engineer ,ePropelled Pvt.Ltd.,Chennai

<sup>3,4</sup> Student, St. Joseph's Institute of Technology, Chennai.

Email: suganyadevi-eee@saranathan.ac.in

### Abstract

A simplified photovoltaic based Speed control of Induction motor (IM) using SEPIC converter is proposed. It improves overall performance of the system. Solar PV system consists of two stages of power transformation. Initial stage maximum power is absorbed from the solar PV panel using MPPT algorithm. Maximum power in the solar panel depends on variation of temperature, PV array voltage and isolation level. Solar PV output is fed to the SEPIC converter. Varying the duty ratio of the SEPI converter input voltage of the motor to be controlled. Next stage different Speed is achieved by changing the voltage of IM. Stability is attained with help of implementing PI controller in closed loop system. PI controller eliminates noise signals and increase the steady state accuracy. New proposed method has high voltage gain, low voltage and current ripple factor, and constant Speed control of IM. Existing water pumping system used with boost converter, it provides less efficiency, more ripple factor. Normally current and voltage ripples create harmonics, harmonics are reduced by connecting large capacitor or an LC filter. It makes the system more complicated, expensive and inefficient. New system with SEPI converter overcome the drawbacks. Induction motor becomes more familiar due to its advantages like self starting torque, high power factor, simple in construction and low maintenance. In Agriculture pumping system used for irrigation purpose. This new PV based pumping system provides pollution free environment compared to diesel water pumping system.

**Keywords:** Photovoltaic cells, MPPT, Speed control, SEPI converter

### 1. INTRODUCTION

Recent years need of renewable energy sources are increased day by day. It provides pollution less and healthy Environment. But most promising one in renewable energy source is installation amount of solar PV array is costlier one and have poor efficiency. Olden days efficiency of solar PV array is in the range of 5- 10%. Nowadays efficiency can be improved up to 15-16%, it is the best alternative sources for conventional energy like fossil fuel system. MPPT algorithm is used to get more power from solar PV Panel, MPPT is required to operate the PV array at its maximum PowerPoint. Solar water pumps [1-3] playing a vital role in rural areas, where the electricity is not available. Solar power fed water pumps using in remote areas for irrigation, normally most of the water pumps are running with non-renewable sources. These non-renewable sources induces the green house gases it leads to global warming. Solar PV based water pumping system is more convenient compared to diesel based water pumping system [4]. Major difficulty in this system is to maintain the active power of the PV system. In PV system due to solar radiation active power changing, MPPT retaining constant voltage of the system. MPPT is achieved by different algorithms are perturbation and observation (P&O), incremental

# Design and Development of SEPIC Converter Fed BLDC Motor Drive for Photovoltaic Application

M.V.Suganyadevi\*,D.Lakshmi<sup>1</sup>L.Ajay<sup>2</sup>,T. Ananth<sup>3</sup>,N. Balaji<sup>4</sup>,K. Mathavan<sup>5</sup>

<sup>1</sup>Associate Professor/EEE, AMET Deemed to be University, Chennai

<sup>2,3,4,5</sup>UG Scholar, Department of Electrical Electronics Engineering,  
Saranathan College of Engineering, Tiruchirappalli, Tamilnadu, India.

\*[suganyadevi-eee@saranathan.ac.in](mailto:suganyadevi-eee@saranathan.ac.in), <sup>1</sup>[lakshmiee@gmail.com](mailto:lakshmiee@gmail.com).

<sup>2</sup>[ajaylakshmanan98@gmail.com](mailto:ajaylakshmanan98@gmail.com), <sup>3</sup>[ananth19981@gmail.com](mailto:ananth19981@gmail.com),

<sup>4</sup>[balaji23899@gmail.com](mailto:balaji23899@gmail.com),

<sup>5</sup>[mathavaeee@gmail.com](mailto:mathavaeee@gmail.com)

## Abstract

*In this paper, a solar photo voltaic (SPV) array fed through SEPIC and VSI to BLDC motor. Even though BLDC driver design part is quite complicated, it's mostly preferred because of its efficiency and High-Power density in now a day and it difficult to maintain PV voltage constant at all time. To maintain PV output voltage constant, Converter is required. Various converters are in practice, among all converters, SEPIC provides non-inverting output voltage and perform both buck as well as boost operation. Three phase VSI is used for achieve electronic Commutation in order to run BLDC motor. Finally, DC voltage from SEPIC that fed to BLDC through three phase VSI. This paper mainly proposes a PV cell integrated SEPIC converter feeding a rated voltage to BLDC motor. MATLAB/SIMULINK based model is developed and simulation results are presented.*

**Keywords:** photovoltaic (PV), BLDC Motor, SEPIC , Voltage Source Inverter (VSI)

## 1. INTRODUCTION

In modern world electricity generation lack due to unavailability of fossil fuel in recent times, to reduce the utilization of electricity by practicing low power consumption loads in household appliances especially fan that is induction motors. It is replaced by BLDC motor [15,18]. Solar PV array power that fed to BLDC through driver (VSI). Here problem is the PV array not capable of providing same power to load in all situations. It may vary based on sun radiation intensity [1]. SEPIC provides constant output voltage and input voltage has wide variations around the rated voltage for duty cycle above 0.5 it will boost the voltage and below 0.5 it will buck the voltage. The SEPIC converter exchanges energy between the capacitors and inductor in order to convert the voltage from one level to another and SEPIC produce non-inverted output voltage [2]. BLDC has high starting torque, high efficiency, high density compared to the other motors, electronics [10, 11]. BLDC motor is driven by a three-phase inverter with conducting interval for each phase is 120-degree, in this 120-degree mode of conduction each switch conducts for 120-degree time period. Here two switches will conduct simultaneously at any instant of time after every 60-degree. one of conducting switches is turned off and another switch will start conducting. Delay of 60-degree between turning on and turning off of switches of same leg to short circuit of switches delay of switching is necessary. The dead-time period of 30-degree is provided between two series switches that enough to avoid short circuit [9]. Voltage Source Inverter (VSI) is operated in 120-degree mode of conduction for eliminating the switching losses [4]. So, this paper proposed with design part of SEPIC and VSI. PV system integrated SEPIC converter feeding the BLDC drive. BLDC drive is operated with open loop speed control the simulation results are presented for various speed.

# MODELING AND ANALYSIS OF GCP BASED PV SYSTEM WITH ZINC-AIR BATTERY STORAGE FOR COMBAT VEHICLES

R.Kishore Kumar<sup>1</sup>, Dr.P.Sivachandran<sup>2</sup>, Dr.M.V.Suganyadevi<sup>3</sup>

<sup>1</sup>Research Scholar, Center for Research, Anna University, Chennai.

<sup>2</sup>Professor, Vel Tech Multi Tech Dr.Rangarajan Dr.sakunthala Engineering College, Chennai.

<sup>3</sup>Associate Professor, Saranathan College of Engineering, Trichy.

<sup>1,2,3</sup> email id: kishore8192@gmail.com, sivaranjaniuma@gmail.com, mvsuganyadevi@gmail.com

**Abstract:** *Combat vehicles are mainly dependent on diesel combustion engine and battery bank for power demand in remote areas for monitoring and controlling electrical equipments, sensors, control systems and communication devices etc. In the proposed system existing diesel combustion engine is integrated with GCP (Green Colored Polycrystalline) solar panel and Zinc-Air battery. Among various kinds of solar panels the GCP panels are difficult to track or see from satellite and easy to hide from enemies. A perturbs and observes MPPT algorithm is implemented in MATLAB/SIMULINK environment. The Zinc-Air batteries are embedded in the combat vehicles to provide a continuous power for long time in remote areas without any intermittence. In night time Zinc-Air battery "inhales" oxygen from the free air which acts as the cathode reactant. The virtually limitless supply of air enables the zinc air cells to offer continuous power and it has many performance advantages compared with lithium ion battery. The cost and loss investigations were carried out using PVsyst 6.5.2 and HOMER software.*

**Key words:** *GCP, Perturb and Observe algorithm, Zinc-air battery, HOMER.*

## 1. INTRODUCTION

The worldwide fuel consumption [1] by every transport vehicle and combat vehicle has increased rapidly and estimated that the increase in fuel consumption is 41 percent during last century. Now the fossil fuels (liquid and natural gas) are been the primary energy source for the present scenario. Sustained urbanization, industrialization, and increased use of vehicle for every purpose lead to price increment. Demand in fuel led to unprecedented dependency on fuels. Presently, the most important concerns regarding fuels are the harmful gas emissions and the irreversible depletion of natural resources.

Based on the energy statistics the global carbon dioxide emissions will increase by 39 percent to reach 40.4 billion metric. Emission and pollution are the key concern with traditional vehicle. Liquid fuels used in vehicle produce carbon dioxide, sulfur dioxide and nitrogen oxides in day today life. Present vehicle use a diesel or petrol engine where it

converts the chemical energy into mechanical energy but the availability of fuel will be less in upcoming years. The carbon di-oxide emission from vehicle is more harmful to environment and particularly to the human health, animals [2] [3]. The depletion of fossil fuel reserves has placed a lot of importance on the role of alternative and greener sources of fuels to drive vehicle.

Among various kind of renewable energy [4], solar energy for green power generation and Zinc Air battery for charge storage leads to design the hybrid vehicle. The GCP based solar and Zinc Air battery powered hybrid vehicle will become a promising economical vehicle. It offers many advantages such as incurring no fuel costs, not being polluting, required little maintenance, and emitting no noise. But the output power varies randomly due to fluctuation of solar insolation and climatic conditions in order to overcome the fluctuation Diesel engine driven generator for electrical energy is used to provide an uninterrupted energy sources during emergency.

Diesel engine driven generator is coupled with PV for power compensation. Then the system convert all the resources in to one form typically DC electrical power and according to the required load condition it can be modified using inverters. The aggregated output is used to supply a variety of loads used in a system to drive all electronic and electrical devices connected in combat vehicle like sensors and monitoring devices.

PV completely disappears during the night hours and Zinc Air battery produce continuous energy with help of by in-haling oxygen. It works as a compensator to the fluctuating power output of the photovoltaic array. The design process of hybrid energy systems requires the power management controller for selection of the most suitable combination of power sources. Generating the power with help of solar panel and Zinc Air battery reduces carbon di-oxide emission.

# Development of IoT Architecture for Physically Challenged People Using BLYNK Server

S.Murugesan<sup>1</sup>, C.Kalavalli<sup>2</sup>, S.Vijayalakshmi<sup>3</sup>, S.R.Paveethra<sup>4</sup> and M.V.Suganyadevi<sup>5</sup>

<sup>1,2,3,4</sup>Assistant Professor, <sup>5</sup>Associate Professor,

<sup>1,2,3,4</sup>Department of EEE, K. Ramakrishnan College of Technology, Trichy-621112, India.

<sup>5</sup>Department of EEE, Saranathan College of Engineering, Trichy-620012, India

## ABSTRACT

Now a very speed of life keep monitoring of physically challenged people are very difficult. By checking the health report of physically challenged people at residence is a tough task. Especially long aged physically challenged peoples should be continuously monitored and their relatives need to be informed by their health report from periodic while at work. So we need an innovative system that automated this work with ease of operation. Our project keep towards a smart physically challenged people health monitoring system that has used Sensors to monitor physically challenged people health and uses net connection to inform their relatives in case of any problems happened. Our project has checked the temperature as well as human heartbeat sensing to keep track of health. Objective of this project work was to propose and develop an Internet of Things (IoT) based system for physically disabled people. A dynamic system consisting of sensors, nodemcu esp8666, Wi-Fi connected over an internet was developed. Communication between hardware and software was done using RS232 communication. With this system, patient on reaching the Higher Limit (HL) or Lower Limit (LL) can send alerts to all the mobile numbers entered over the network. The BLYNK IoT android application was used to send the Notification through touch on buttons. Thus BLYNK IOT based physically challenged people health tracking system effectively uses internet to monitor physically challenged people health stats and save lives on time.

**KEY WORDS:** INTERNET OF THINGS, HIGHER LIMIT, BLYNK IOT, HEALTH CARE, NODEMCU,.

## INTRODUCTION

Patients suffer from wide variety of disabilities can upto the range in severe from low of stamina to loss of health. Physical inability results in physical difficulties of different variation. The IoT technology provides proactive help to patients with it advanced human machine interaction by internet networking physical devices

and embedded sensors which enables these objects for collecting and exchanging data. Physical disability results in physical difficulties of different levels. (Murugesan. S et al., 2019) The IoT technology provides proactive help to patients by internet networking physical devices and embedded sensors. (S.Vijayalakshmi et al., 2020) Paralyzed patients are provided with unobtrusive support by the caregivers with the help of an application where a combination of services such as, Patient monitoring system of physically challenged peoples.

## ARTICLE INFORMATION

\*Corresponding Author: [murugesanmep@gmail.com](mailto:murugesanmep@gmail.com)

Received 10th May 2020 Accepted after revision 20th June 2020

Print ISSN: 0974-6455 Online ISSN: 2321-4007 CODEN: BBRBCA

Thomson Reuters ISI Web of Science Clarivate Analytics USA and Crossref Indexed Journal



NAAS Journal Score 2020 (4.31) SJIF: 2020 (7.728)

A Society of Science and Nature Publication,

Bhopal India 2020. All rights reserved.

Online Contents Available at: <http://www.bbrc.in/>



## Modified Bridgeless Buck Rectifier for Led Applications

C. Pearline Kamalini<sup>\*1</sup>, M. V. Sugvahnnyadevi<sup>2</sup>

<sup>1</sup>Assistant Professor, <sup>2</sup>Associate Professor, Department of Electronics and Electrical Engineering, Saranathan College of Engineering, Thiruchirapalli, Tamil Nadu, India

\*Corresponding Author: pearline-eee@saranathan.ac.in

### ABSTRACT

A great bridgeless buck rectifier for power factor control with a single inductor is planned which extensively builds the proficiency by decreasing the quantity of directing semiconductor segments. The low usage of the attractive segment in the customary bridgeless buck rectifier builds execution. The proposed rectifier's proficiency is additionally improved by disposing of information connect diodes. Likewise, the rectifier duplicates its yield voltage which broadens utilize capable energy of the mass capacitor after an exit the line voltage. The reenactment of open circle controlled bridgeless buck PFC rectifier with a single inductor and altered converter is acted in MATLAB programming thus its activity is confirmed. The prototype circuit is designed to produce a 12V output voltage suitable for LED applications.

**Keywords**--Bridgeless Converters, Buck Converter, Magnetic Utilization, Power Factor correction, Rectifier

### INTRODUCTION

Presently a-days ac-dc power supplies are utilized in numerous electrical and gadgets applications like battery charges, personal computers, and so forth These force supplies should satisfy certain global guidelines to have required proficiency at various force levels. However, power supplies associated with ac mains present symphonious flows inside the utility. It is very notable that these consonant flows cause a few issues like voltage mutilation, warming, clamor, and

lessen the fitness of line to deliver energy.

Electrical planners are persistently looking for occasions to expand PF, decrease THD check, improve proficiency in this force supplies. Consequently, Bridgeless force factor rectification circuits are one among the answers for satisfying these necessities [1].

A scaffold diode rectifier followed by an ordinary lift converter has is the most normally utilized PFC circuit as a result of its straightforwardness and great PF execution [2]. Nonetheless, a lift PFC front end shows 1 – 3 % lesser effectiveness at 100V line contrasted with that at 230V line. This drop of proficiency at low line can be ascribed to expanded information current and produce higher misfortunes in semiconductors. Thus to diminish this misfortune bridgeless lift geography which disposes of the utilization of extension rectifier was presented [3]. The bridgeless lift PFC has similar disadvantages to regular lift converter, for example, high voltage stress, high normal mode commotion, no inrush current insurance, and low attractive usage. These disadvantages of lift PFC converter can be overwhelmed by actualizing buck PFC geography.

This paper analyses the operation of a Modified bridgeless buck rectifier with a single inductor [4] and the block diagram is shown in Fig.1. Generally, a bridgeless buck rectifier has its output voltage twice that of a conventional buck rectifier, it is designed in such a way that it needs harmonic limit specifications. Moreover switching losses of the dc-dc output stage of bridgeless buck rectifier is effectively lower than that of boost PFC circuit [5].

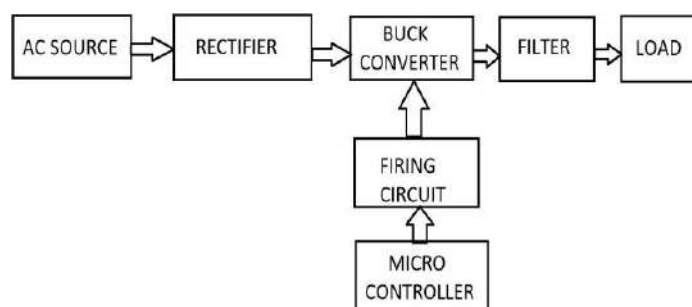

# Improved STATCOM Control to Improve Transient Stability of Power of a Power System using PSO technique

*DR.M.V.Suganyadevi*

*Department of Electrical and Electronics Engineering  
Saranathan College of Engineering  
Trichy, India*

*Sankari S*

*Department of Electrical and Electronics Engineering  
Saranathan College of Engineering  
Trichy, India*

*Preethi V*

*Department of Electrical and Electronics Engineering  
Saranathan College of Engineering  
Trichy, India*

*Srijah R*

*Department of Electrical and Electronics Engineering  
Saranathan College of Engineering  
Trichy, India*

**Abstract-**In recent year, photovoltaic is widely used in diverse application. The photovoltaic is a device which converts solar energy into a DC electrical energy. The wind farm produces a ac source by integrating these two renewable energy causes a voltage dip in grid side to overcome this problem we introduces a facts devices. FACTS devices boost power network performance by rerouting facility flow on transmission lines so that thermal limits aren't surpassed, all while meeting grid stakeholders' contractual obligations and increasing system load ability. FACTS devices work in the steady state by providing or consuming reactive electricity, increasing or decreasing voltage, and regulating transmission line or phase series impedance. The benefits of FACTS devices, on the other hand, are based on their form, size, number, and position within the transmission. Particle swarm optimization is one of several heuristic or analytical methods for locating the best locations for given FACTS devices within the power grid (PSO).This paper shows the transient stability of a power system and it is achieved by using a particle swarm algorithm, which was one of the fast simple, fast converging technique. The above mentioned topology is analyzed using MATLAB/ SIMULINK platform and the result is acquired for an inter machine's stability.

**Keywords:** *Multi-machine-DFIG -Facts device-Solar-STATCOM*

## I. INTRODUCTION

Considerable attempts have been made to blend renewable energy in order to satisfy demand, onto grid for long-term and stable generation of electricity. Taking into account the complementary wind and solar energy features, the expansion of the current wind farm with photovoltaic panels will greatly reduce the fluctuations in power generation and increase the operating economy [1]. The primary goal of this paper is really to discuss the use of solar power plants, wind turbines, and synchronous machines concurrently inside the grid of the facility. In this scenario, the intermittent interaction of renewable solar and wind also may threaten grid accuracy and performance. Wind turbines based on double-powered induction generators (DFIG) use small-scale, limited-voltage controlled converters. The low over current withstand capability of DFIG-based wind turbines makes them highly susceptible to grid faults. Modern double fed induction generator systems commonly implement rotor circuit protections to safeguard the rotor side converter (RSC) during fault conditions. Because of insecurity and

# A Novel IUPQC for Multi-Feeder Systems Using Multilevel Converters With Grid Integration of Hybrid Renewable Energy System

NOORUL AMEEN S, PASHITH H, PRAHATHISH B, VAIKUNTH B, DR. M.V.SUGANYADEVI

Saranathan College of Engineering, Trichy

## ABSTRACT:

Multi-Microgrid (MMG) is a combination of two or more microgrids (MGs), based on renewable energy sources, integrated at a common point of coupling. However, due to the fluctuating resources and also with different variable loads, it is difficult to maintain a balance between sources and loads, which consequently leads to power quality problems such as voltage and current distortions. In this regard, a novel multi-function device like Interline Unified Power Quality Conditioner (IUPQC) is proposed to mitigate these power quality issues. IUPQC consists of series and shunt active power filter (APF) linked through a common DC link capacitor. However, unlike Unified Power Quality Conditioner (UPQC), in IUPQC, the APFs are individually connected to two independent distribution feeders. The shunt APF mitigates current imperfections of feeder 1 and regulates the DC voltage of the DC link capacitor whereas the series APF mitigates voltage imperfections of feeder. This paper presents the incorporation of IUPQC between two MGs (feeders) in MMG, and design of its controller to compensate and minimize the voltage and current harmonics due to the source and load disturbances

**Keywords:** Power Factor, Power quality Conditioner, Capacitors

## INTRODUCTION

The energy is neither be created nor destroyed but it can be converted from one form to another. The generation of an electrical energy is nothing but the conversion of various other forms of energy into an electrical energy. The electrical power is generated in bulk at the generating stations which are also called power stations. The generated electrical energy is demanded by the consumers. This causes due to power losses and power quality problems in the transmission lines FACTS device is introduced to reduce such problems. Microgrid leads to effective distribution in rural area all distribution includes effective power processor to control and monitor the power exchange between the grid. When such processor get fully exploited it leads to high power quality problems and power consumption by developing narrow band communication and local control algorithm full microgrid is exploited with marginal investment. This study deals with experimental verification of inter line Power Flow Controller. Interline Power Flow Controller (IPFC) is a Concept of Flexible AC Transmission System (FACTS) controller with the unique capability for series compensation with the unique capability of power flow management among multi-line of a substation. In low-voltage residential micro-grids, where number and type of DERs and loads is unpredictable and may vary during daytime, cooperative operation can be achieved by simple cross-communication among neighbor EPPs, without centralized supervisor or additional control units. During disturbances, the generation and corresponding loads can separate from the distribution system to isolate the microgrid's load from the disturbance (providing UPS services) without harming the transmission grid's integrity. The system also shows the possibility to achieve auxiliary functions such as voltage unbalance correction and harmonic current compensation. The DGs are properly controlled to autonomously compensate for voltage unbalance while sharing the compensation effort and also active and reactive powers. The control system of the DGs mainly consists of active and reactive power droop controllers, a virtual impedance loop,



All



ADVANCED SEARCH

Conferences > 2021 IEEE International Power... ?

# Performance investigation of SVR for evaluating Voltage Stability Margin in a Power utility

Publisher: IEEE

Cite This

PDF

Tamilarasan Thiyagarajan ; Suganyadevi Mv ; A.Karuppa Samy ; A. Venkadesan All Authors

## More Like This

Using support vector machines for determining voltage unstable areas in power systems

2008 IEEE 2nd International Power and Energy Conference

Published: 2008

Towards Development of Equivalent Model of Hybrid Renewable Energy Source Plant for Voltage Stability Studies

2021 IEEE Madrid PowerTech

Published: 2021

Show More



## Alerts

Manage Content Alerts

Add to Citation Alerts

3 Full Text Views

### Abstract



Downl PDF

Document Sections

- I. Introduction
- II. Continuation Power Flow
- III. Support Vector Machine
- IV. Simulation Results and Discussions
- V. Conclusion

**Abstract:** Voltage stability margin is one of the key parameters to ensure the credibility of the power system in real time. Voltage stability margin indicates the maximum loading c... **View more**

#### Metadata

**Abstract:** Voltage stability margin is one of the key parameters to ensure the credibility of the power system in real time. Voltage stability margin indicates the maximum loading capacity of the system i.e, further increase in load will collapse the system voltage, and the system becomes unstable. Hence in real time, the evaluation of voltage stability margin is crucial and requires more significance. In recent times, reinforcement learning algorithms attracts a great deal of interest for determining the voltage stability margin. In this paper, voltage stability analysis on the power system has been accomplished using the Continuous power flow method with Spider SVM regression algorithm. The analysis was carried out in the IEEE 118 bus system, with the help of PSAT

Authors

Figures

References

the expected model with the best accuracy for many cases.

IEEE websites place cookies on your device to give you the best user experience. By using our websites, you agree to the placement of these cookies. To learn more, read our Privacy Policy.

Accept & Close

## Password based circuit breaker operation for the safety of lineman during maintenance work

- Sakthi Raja V, Rakesh K.K, Pravin kumar N, Saravanan S,  
Dr.M.V.Suganyadevi

*Department of Electrical and Electronics Engineering, Saranathan College of Engineering, Trichy*

### ABSTRACT

Nowadays, accidental death of lineman is a commonly occurring tragedy. so, it is compulsory for us to guarantee the safety of linemen by adapting a new method of operation. A new system should be adapted to regulate and manage the control panel which consists of all the electrical components and circuit breakers. These accidents are on the rise throughout the country, main reason being miscommunication between the maintenance workers and sub-station workers. The planned system gives a solution for this problem and reduces the risk for linemen. The control to activating/ deactivating the control panel is in the hands of the linemen only. In this new method of operation, a "Passcode or Password" is needed to access the control panel and further to operate the circuit breaker (ON/OFF). An encrypted Passcode/Password is sent from the substation to the circuit breaker operators (linemen), for the purpose of executing maintenance works. The password is registered and forwarded to the lineman's mobile and also to the management panel by the help of GSM module. The received passcode/password is typed in through the matrix keyboard which acts as the input device and also it is interfaced to the microcontroller present inside the panel. The password entered by the lineman is compared with the encrypted passcode received from the substation through the GSM module. Only when both the passwords match, the lineman will be able to access the control panel and to operate the circuit breaker, so he can proceed to do the repair works and maintenance works. If any third party enters a wrong password, he/she will not be able to access or operate the control panel and hence the system will be completely secured.

**Keywords:** Security, lineman, password, control panel

Date of Submission: 21-04-2021

Date of Acceptance: 06-05-2021

### I. INTRODUCTION

In present times, casualties of line-workers due to accidents occurring during maintenance works is on the rise. Until now, to execute maintenance works, Line clearance method is used to shut down the electrical line in which the work is to be done. There are lots of short-comings to this method, like accidental charging of the line due to mistake of the operators at station, which can lead to serious injuries, and in some unfortunate cases, even deaths of line-workers. The employment of microcontrollers can be a solution to this issue. The employment of communication networks will increase the potency of the pilotless devices. This new method with the help of GSM module, reduces the risk of physical contact with the high voltage electrical lines, and enables us to control the circuit breakers automatically. so, we decided to implement GSM based circuit to control the operation of the electrical lines.

A circuit breaker is a protective device which acts as a switch designed to safeguard an

electrical circuit from damage caused by short circuit. When operated manually there is a chance of fatal accidents occurring to the line-workers such as linemen and occurrence of these accidents are steadily increasing during the electric line repair due to the lack of communication and coordination between the maintenance staff and the electric substation staff [1]. Circuit breakers are an important necessity for an electrical system as they play a vital role in protecting the electrical components. And their malfunctioning can cause damage to the electrical equipment and could result in unstable operating conditions. When doing repair works on electrical lines there is a probability of miscommunication between the linemen and substation workers. This miscommunication could result in an accident and result in the death of the line-workers.

There are many major disadvantages to the existing system of Circuit Breaker operation, for example: During maintenance or repair works, the entire line is turned off which is a major

# Performance Comparison of UPQC for Improving the Power Quality with Industrial Controller Techniques

Ananthan Nagarajan<sup>1</sup>, Sivachandran P<sup>2</sup>, Suganyadevi M V<sup>3</sup>

<sup>1</sup>Department of Electrical and Electronics Engineering, Assistant Professor, Veltech Multitech Dr. Rangarajan Dr. sakunthala Engineering College, Chennai, Tamilnadu, India.

<sup>2</sup> Department of Electrical and Electronics Engineering, Professor, Vaigai College of Engineering, Madurai, Tamilnadu, India.

<sup>3</sup>Department of Electrical and Electronics Engineering, Associate Professor, Saranathan College of Engineering, Trichy, Tamilnadu, India.

## ABSTRACT

In the modern power system, the usage of power electronics loads is relatively high and it behaves as a non-linear load. This load causes serious voltage distortion and power quality issues on the transmission and distribution system by injecting the harmonics. The active power filters are used to regulate this problem. A unified power quality conditioner is a combination of series and shunt active power filters. It not only eliminates the harmonics but also it treats all type of voltage and current fluctuations and compensate the reactive power in the distribution system. In this paper unified power quality conditioner with a different control, strategy is introduced to rectify the power quality issues and increase the efficiency of power quality. UPQC concern feedback systems with P, PI, and PID controllers are used to improve the performance of UPQC and compare the different strategies using MATLAB/SIMULINK.

**Index Terms**-- Power Quality, APF (active power filters), Harmonics.

## I. INTRODUCTION

In general, the power system consists of generation, transmission, and distribution. Apart from that generation, transmission and distribution have the major problem called power quality issues. The power quality issues are voltage sag, voltage swell, interruption, harmonics, flickers, etc. Now a day we frequently using many sensitive loads such as computers, led television, etc. These loads have electronic circuits for smart operation. Such loads may cause improper power quality which leads to huge power loss, misbehavior of equipment, inferences with the nearest communication lines, and so forth [1]–[4]. Additionally, the power electronics loads may inject the harmonics into the grid. Thereby reducing the equipment's performance and its life span. Despite the above disadvantages, such types of loads are needed to reduce manpower, so the elimination of sensitive loads is not possible.

. Due to poor power quality, such equipment may fail. To diagnose this problem and also to improve the power quality we have the only solution, called Unified Power Quality Conditioner [1].

## Performance enhancement of BLDC motor using PID controller

S. Usha<sup>1</sup>, Pranjul Mani Dubey<sup>2</sup>, R. Ramya<sup>3</sup>, M.V. Suganyadevi<sup>4</sup>

<sup>1,3</sup>Department of Electrical and Electronics Engineering, SRM Institute of Science and Technology, Kattankulathur, India

<sup>2</sup>Department of Chemical and environmental engineering, University of Cincinnati, Cincinnati, United States of America

<sup>4</sup>Department of Electrical and Electronics Engineering, Saranathan College of Engineering affiliated to Anna university, Trichy, India

### Article Info

#### Article history:

Received Feb 7, 2021

Revised Jul 12, 2021

Accepted Jul 23, 2021

#### Keywords:

BLDC motor

PI-controller

PID- controller

Firing signal generator

Frequency analysis

Speed control

### ABSTRACT

Mainly the DC motors are employed in most of the application. The main objective is to Regulate the DC motor system. A motor which displays the appearances of a DC motor but there is no commutator and brushes is called as brushless DC motor. These motors are widespread to their compensations than other motors in relationships of dependability, sound, efficiency, preliminary torque and longevity. To achieve the operation more reliable and less noisy, brushless dc motors are employed. In the proposed work, dissimilar methods of speed control are analysed. In real time submission of speed control of BLDC motor, numerous strategies are executed for the speed control singularity. The modified approaches are the employment of PI controller, use of PID controller and proposed current controller.

*This is an open access article under the [CC BY-SA](https://creativecommons.org/licenses/by-sa/4.0/) license.*



### Corresponding Author:

S. Usha

Department of Chemical and environmental engineering

University of Cincinnati

2600 Clifton Ave, Cincinnati, OH 45221, United States of America

Email: ushakarthick@gmail.com

## 1. INTRODUCTION

BLDC motors have an outsized number of applications in industries. The only difference between a BLDC motor and a permanent synchronous motor is the back EMF [1], [2]. The back EMF in a permanent synchronous motor is of sinusoidal form and in a BLDC, machine is of trapezoidal form. Commutation is the process of interchanging the current through the coil which make the motor to spin. The commutation of the currents is done with the help of automatically changes DC to AC which is basically supplied by a DC source.

The currents which induced in the rotating part can be failed due to very high resistivity of mutually stainless steel and magnet. Damping winding should be of very less value because due to this only magnetic flux got decreases [3], [4]. The BLDC Motor is run on DC supply rather than AC Supply. The DC voltage is converted into 3-phase AC voltage, which is then supplied to the motor. AC source can also be used and then it can be converted into DC but the main disadvantage of converting AC to DC is that it will cause new problems like THD, poor power factor, poor quality etc. that's why BLDC motors are run on DC source and not on AC [5], [6]. The DC source can be directly connected or it can be given by connecting it across any of the converters like DC-DC converter, SEPIC converter etc. BLDC fed with diode bridge rectifier has poor power factor. By using different converter techniques Voltage can be controlled and power factor can be improved [7], [8].

Different simulations are performed by researchers to analyse the performance and process of the procedure to get the better speed regulation and higher starting torque of the motor. The researchers are

## Design and Implementation of Proportional Resonant Controller for Power Inverters

C.Pearline Kamalini<sup>1</sup>, Dr.M.V.Suganyadevi<sup>2</sup>, Bharathi Freetha K<sup>3</sup>,  
Madhu shree S<sup>4</sup>

<sup>1</sup> AssisatProfessor, [pearline-eee@saranathan.ac.in](mailto:pearline-eee@saranathan.ac.in)

<sup>2</sup> Associate Professor, [suganyadevi-eee@saranathan.ac.in](mailto:suganyadevi-eee@saranathan.ac.in)

<sup>3,4</sup> UG students, [ms.s.madhushree@gmail.com](mailto:ms.s.madhushree@gmail.com)

Department of EEE, Saranathan College of Engineering, Trichy

### ABSTRACT.

This paper provides a design procedure of single-phase inverter with LC filter and the inverter load current is regulated by Proportional-resonant controller. The Proportional-resonant controller provides an effective control of single-phase inverter suitable for various Distributed Generation systems i.e grid connected and stand-alone systems. The performance study is based on frequency response and the model is simulated in MATLAB/SIMULINK environment which provides better stability, improved load current regulation with low THD value prescribed in the IEEE standards. The prototype model is also fabricated with Atmega328 processor and performance are satisfied.

**Keywords:** PV inverter, LC filter, PR controller, APF,THD.

Date of Submission: 10-07-2021

Date of Acceptance: 26-07-2021

### I. INTRODUCTION

Inverter is one of the main power conditioning devices in the integration of renewable energy, other distributed energy sources. Voltage source converter is the basic component in power quality improvement to filter out the harmonics i.e Active Power filters and Facts devices. The power conversion from DC to AC with good power quality is from an Inverter. As a consequence, power converters for renewable energy sources are becoming increasingly common. It's vital to produce clean and green energy. It is important to sustain the inverter output and the proposed system is designed with an LC filter to filter out high frequency components. [1] The various control techniques to control the PV inverters to provide high quality of output current and voltage connected to a linear or

non-linear load are hysteresis current controller, Predictive Current controller, Proportional Integral (PI) controller and Proportional Resonant (PR) controller [2]. The effect of harmonics such as power losses, decay of quality power reduces the equipment life and failure of components. In a grid-connected application, for example, the power converter must follow many typical grid parameters, including voltage, current, frequency, harmonics, power factor, and flicker.

Based on literature the hysteresis controller is simple, unconditional stability and good accuracy with comprehensive band harmonic spectrum. The predictive controller force the measured current to track the reference current. The famous conventional controller PI controller produces steady state error while tracking the sinusoidal reference due to dynamic integral term[3]. The proposed PR controller provides zero steady state error, high gain in wide range of frequency response with fast tracking of specified references and with low value of %THD. The block diagram of single-phase inverter with PR controller is shown in Fig:1.

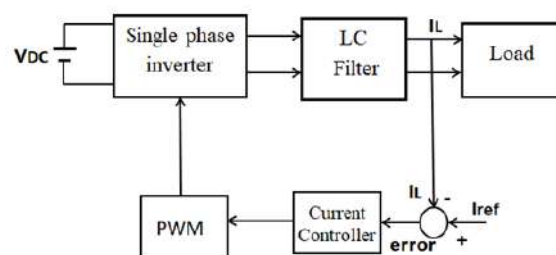

Fig.1 Closed loop Block diagram of single-phase inverter





# UPQC-based effective mitigation of harmonics by signal processing approach

Ananthan Nagarajan<sup>1</sup> · M. V. Suganyadevi<sup>2</sup>

Received: 21 August 2021 / Revised: 30 November 2021 / Accepted: 2 December 2021  
© The Author(s) under exclusive licence to The Korean Institute of Power Electronics 2021

## Abstract

This paper introduces a solution for solving the harmonics problem in power distribution systems. The unified power quality conditioner (UPQC) is a combination of shunt and series converters linked by a common capacitor. Controlling the link voltage and generating the reference current are the two main objectives of this work. An adaptive PI controller is employed for regulating the link voltage. For reference current generation, the DDSRF (decoupled double synchronous reference frame) theory is employed, which assists in eliminating the harmonics that occur in the system. By the DDSRF theory, a THD of around 3.3% is accomplished, and to further minimize the harmonics, a signal processing approach is implemented. Pre-processing, segmentation and feature extraction are the three major steps used in this paper to accurately extract the reference current. Finally, the obtained test data is classified with the trained data by the DCNN (deep convolutional neural network). Thus, the reference current is extracted clearly by this technique, and the THD is minimized to 0.98%. This work is implemented in MATLAB, and the results are verified through hardware implementation.

**Keywords** UPQC · Adaptive PI controller · DDSRF theory · Weiner filter · Hilbert transform · DCNN

## 1 Introduction

Power quality (PQ) is necessary in distribution systems and PQ deals with both current and voltage quality, since deviations in current and voltage from their ideal values create PQ disturbances. Among the various disturbances, harmonic distortions have the most serious effects in terms of the overall performance of system. In most power systems, non-linear elements and switched loads are present and these distortions result in additional losses in the loads. Mitigating these harmonics is necessary and several types of active filters, passive filters, de-rating transformers, etc., are employed for the mitigation of harmonics [1–3]. In addition, some multifunctional grid connected inverters are utilized in mitigating the problems associated with the current and

voltage quality [4]. However, these inverters require more VA. Thus, FACTS devices are widely applied in power systems for harmonic mitigation. In addition, FACTS devices have more economic benefits along with effective energy utilization [5, 6].

One type of FACTS device that assists in the compensation of both source current and load voltage harmonics is the UPQC. The UPQC is employed with an electronically coupled transformer, which assists in the elimination of harmonics [7]. Using various control techniques like P, PI, PID and Fuzzy, power quality enhancement is accomplished with the assistance of the UPQC [8, 9]. To effectively eliminate the harmonics that occur in a system, the generation of a reference signal is necessary and there are several theories for generating reference signals. The extraction of reference current includes either time-domain or frequency domain methods. The time-domain methods contain the discrete Fourier transform, while frequency domain methods include p–q theory and d–q theory [10]. Although, the p–q theory is simple and efficient, it is not applicable for  $1\phi$  systems. Reference current is also generated by the p–q theory on the basis of the second-order integer and modified SRF theory which provides accurate results at the expense of an increased computational burden [11, 12]. In [13], harmonic

✉ Ananthan Nagarajan  
jananthan1991@gmail.com

<sup>1</sup> Department of Electrical and Electronics Engineering, Vel Tech Multi Tech Dr. Rangarajan Dr. Sakunthala Engineering College, Chennai, Tamil Nadu, India

<sup>2</sup> Department of Electrical and Electronics Engineering, Saranathan College of Engineering, Trichy, Tamil Nadu, India

# Design and Analysis Of Quadratic Boost Converter

M.Priyanga<sup>1</sup>, B.Paranthagan<sup>2</sup>, Dr.S.Vijayalakshmi<sup>3</sup>, M.Marimuthu<sup>4</sup>

PG Scholar, EEE, Saranathan College of Engineering, Trichy, India<sup>1</sup>  
 Associate Professor, EEE, Saranathan College of Engineering, Trichy, India<sup>2,3</sup>  
 Assistant Professor, EEE, Saranathan College of Engineering, Trichy, India<sup>4</sup>

**Abstract—** In this paper the simulation of a High gain DC-DC Quadratic Boost Converter is presented. Operation of the QBC is analyzed, leading to mathematical expressions that can be used to design a converter. Based on the derived analytical expressions, a 200W, QBC converter is designed. The proposed quadratic boost converter implemented in MATLAB/SIMULINK.

**Keywords—**DC-DC converter, Quadratic Boost Converter

## I. INTRODUCTION

In recent years for a great number of appliances dc-dc converter is employed. Normally in renewable energy system, the system having low output characteristics to recover this demand DC-DC converter topology is implemented. For maintaining the output DC voltage range in PV array and fuel cells, converter is wont to improve the output voltage. But during the switching operation the voltage stress is high. While selecting the converter the concentrating options are; once switch is activate it should attain the zero voltage crossing, when PhotoVoltaic array is connected to the grid the converter should ought to offer the high terminal voltage for low input vary. The converter which provides the high output vary at low voltage stress is a lot of economical. Voltage gain typically supported duty magnitude relation thus by selecting the passive parts components the duty magnitude relation can be restricted.

## II. QUADRATIC BOOST CONVERTER

The circuit diagram of a quadratic boost converter is shown in Fig1. The circuit comprises of a single switch S, three diodes D1, D2 and D3, two capacitors C1 and C2, two inductors L1 and L2 and a load resistor R. The circuit operation is entirely in view of the supposition that the switch S is perfect in operation and capacitors C1 and C2 is

thought to be substantial so the voltage over the capacitors VC1 and VC2 are almost consistent over an switching period. At the point when the switch is ON: The comparable circuit schematic of the QBC amid the ON state is appeared in Fig 2.when switch S is turned on D2 is forward one-sided, while D1 and D3 invert one-sided. Currents are provided to L1 and L2 by Vin furthermore, C1 respectively.

At the point when the turn is OFF: The method for operation and current stream heading of QBC amid OFF state is appeared in Fig 3. In this condition D1 and D3 are forward biased, while D2 switch is reverse biased. L1 and L2 are charging C1 and C2 individually. During this state, iL1 and iL2 is diminished.

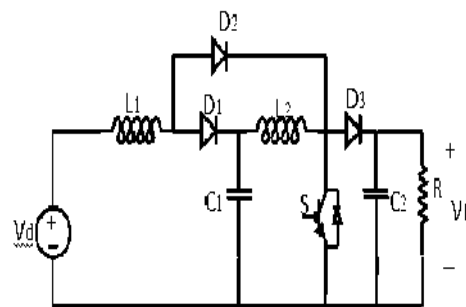

Fig1. Quadratic Boost Converter

## III. STEADY STATE ANALYSIS

Mode 1 (Switch S = on)

The equivalent circuit schematic of the QBC during the ON state is shown in Fig 3.6.when switch S is turned on D 2 is

# Symmetric Multilevel Inverter Using DC-DC Zeta Converter

S.Srinithi

Department of Electrical and  
Electronics Engineering  
Saranathan College of Engineering  
Trichy, India  
ssrinithiselvi@gmail.com

Dr.S.Vijayalakshmi

Department of Electrical and  
Electronics Engineering  
Saranathan College of Engineering  
Trichy, India  
bksvijji@gmail.com

M.Marimuthu

Department of Electrical and  
Electronics Engineering  
Saranathan College of Engineering  
Trichy, India  
marimuthueeephd@gmail.com

B.Parathagan

Department of Electrical and  
Electronics Engineering  
Saranathan College of Engineering  
Trichy, India  
parathagan-eee@sarathan.ac.in

**Abstract**— This paper presented is an attempt to suggest a high-gain Zeta converter with a voltage multiplier cell is fed with multilevel H-Bridge inverter. A perfect mixture of a slightly modified version of the regular Zeta converter and a voltage multiplier unit is the proposed circuit. The voltage addition of the suggested refitted zeta enhances the voltage gain by increasing n time of the multiplier unit. The proposed converter decreases the voltage issue over the transition, which concludes the superior output and the gain is improved without disrupting the primary circuit. In inverter to use minimum switches and get M-level output. The thorough study of the proposed converter with numerical analysis is now achieved with the help of MatLAB/Simulink.

**Keywords**— Multilevel Zeta (MLZ), Voltage-Multiplier unit (VMU), H-Bridge inverter.

## I. INTRODUCTION

DC to DC converters are the circuits that transform direct current sources to another voltage level by adjusting the duty cycle of the main circuit switches. These converters are commonly used in power distribution systems, dc motor drive applications and switched mode dc power system. Now a day it can be used in the maximum power point tracking in PV panel like a buck-boost converter. The Zeta converter design is identical to the SEPIC converter. The advantages of Zeta converter over the SEPIC converter are: 1. It has stable feedback loop even if the voltage range is wide it can provide a very good output voltage with relation. 2. Low output ripple, the output ripple of the Zeta converter is also lower than an equivalent SEPIC converter design. The multilevel Zeta converter is the combination of both conventional Zeta and the Voltage Multiplier Unit (VMU). The number of levels is easily added by the number of capacitors and diodes.

The excellence output voltage waveform depends on the number of inverter voltage level sand the number of output voltage level rises, the waveform become more sinusoidal [6]. To fulfill this requirement multilevel inverters are commonly used for their sinusoidal output wave. It is very challenging to get pure sine wave AC output with the use of

filter and it is very expensive, this can be easily achieved through multilevel inverter's (MLI) used. In MLI's are 1. Single source inverter 2.Multi source inverters. In our suggested circuit consists of single DC source only. This topology can be designed for both high and low power application. In the suggested scheme consists of two stages: the first is a multi-level DC-DC Zeta converter, which gives the DC output voltage value with the help of the VMU, get the N number of output levels, and the second one is the level circuit combine with H-Bridge inverter circuit, get the M level inverter outputs. Its actual details are seen in Fig.1.The M level stepped alternating current (AC) output voltage is easily obtained by only one DC source, with low number of power electronic components.

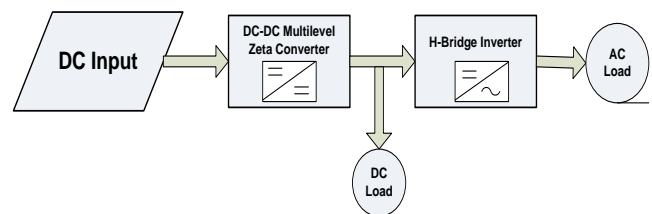

Fig. 1. Block diagram of proposed model

The main application of the MLI's are solar PV system, E-vehicles', auto mobiles, Fuel cells and Uninterrupted power supplies (UPS). Normal MLI's are complex structure need more input sources and stresses along the switches. In our suggested methodology simple in structure and used only one input source also reduced the switches stress. It is a symmetric MLI's DC source outputs are equal in magnitude.

## II. PROPOSED CONVERTER WITH INVERTER

The proposed model of DC-DC Zeta converter fed MLI's is illustrated in Fig. 2.

The Zeta converter is connected to the multiplier unit which is fed to the MLI via level switches. The DC-AC conversion is based on the Level circuit and the H-Bridge inverter.

# IMPLEMENTATION OF P & O ALGORITHM FOR MULTI LEVEL CASCADED- BOOST CONVERTER

Reka.J<sup>1</sup>, Vijayalakshmi.S<sup>2</sup>, Marimuthu.M<sup>3</sup>, Paranthagan.B<sup>4</sup>, Vijay.R<sup>5</sup>, Venugopal.R<sup>6</sup>

<sup>1</sup>Department of Electrical and Electronics Engineering, Cauvery College of Engineering, Trichy, Tamilnadu, India, Mail id: [reka.zenith@gmail.com](mailto:reka.zenith@gmail.com)

<sup>2</sup>Department of Electrical and Electronics Engineering, Saranathan College of Engineering, Trichy, Tamilnadu, India, Mail id: [bksvijji@gmail.com](mailto:bksvijji@gmail.com)

<sup>3</sup>Department of Electrical and Electronics Engineering, Saranathan College of Engineering, Trichy, Tamilnadu, India, Mail id: [marimuthueeephd@gmail.com](mailto:marimuthueeephd@gmail.com)

<sup>4</sup>Department of Electrical and Electronics Engineering, Saranathan College of Engineering, Trichy, Tamilnadu, India, Mail id: [paranthagan-eee@saranathan.ac.in](mailto:paranthagan-eee@saranathan.ac.in)

<sup>5</sup>Department of Electrical and Electronics Engineering, Saranathan College of Engineering, Trichy, Tamilnadu, India, Mail id: [vijay-eee@saranathan.ac.in](mailto:vijay-eee@saranathan.ac.in)

<sup>6</sup>Department of Electrical and Electronics Engineering, Saranathan College of Engineering, Trichy, Tamilnadu, India, Mail id: [satheesh-eee@saranathan.ac.in](mailto:satheesh-eee@saranathan.ac.in)

*Abstract*— Maximum power point (MPP) monitoring is an unavoidable feature of a solar (PV) array energy conversion system. Thus an attempt is made to implement the new multi-level cascaded boost converter for maximum power point tracking. MPPT plays a vital role in Photo Voltaic power system as they provides the maximum power output for PV System for different weather conditions and thereby gives improved array efficiency. The goal is accomplished here by implementing the Perturb & Observe MPPT algorithm, which also provides high voltage gain by the use of the proposed converter circuit. The MATLAB/SIMULINK is used for Testing and Implementing the required objective. The algorithms are implemented in m-file of MATLAB.

**Keywords:** *Photovoltaic Module, Multi Cascaded Boost Converter, MPPT Controller, Perturb and Observe method, PSIM.*

## I. INTRODUCTION

Environmental problems empower the world towards renewable energy production. The sunlight is the huge source of inexhaustible energy and the solar array are handled by the influence of the solar radiation, shading and temperature. Solar energy is effectively utilized by Photovoltaic System. The photovoltaic system is used to get the electrical energy from the PV system and restored in the battery

During the non-availability of solar energy, the battery storage system is used for supplying the power. The electric power obtain from solar panel is maximised using P&O algorithm by MPP Tracking. The DC-DC

# Design and Implementation of Multilevel Cascaded Boost converter fed Multilevel Inverter

Vijayalakshmi.S<sup>1</sup>, Marimuthu.M<sup>2</sup>, Paranthagan.B<sup>3</sup>, Dharneesh.K<sup>4</sup>, Manojkumar.P<sup>5</sup>, Kalaiarasan.G<sup>6</sup>, Surendran.R<sup>7</sup>

<sup>1</sup>Department of Electrical and Electronic Engineering, Saranathan College of Engineering, Trichy, Tamilnadu, India, Mail id: [bksviji@gmail.com](mailto:bksviji@gmail.com)

<sup>2</sup>Department of Electrical and Electronic Engineering, Saranathan College of Engineering, Trichy, Tamilnadu, India, Mail id: [marimuthueeephd@gmail.com](mailto:marimuthueeephd@gmail.com)

<sup>3</sup>Department of Electrical and Electronic Engineering, Saranathan College of Engineering, Trichy, Tamilnadu, India, Mail id: [paranthagan-eee@saranathan.ac.in](mailto:paranthagan-eee@saranathan.ac.in)

<sup>4</sup>Department of Electrical and Electronic Engineering, Saranathan College of Engineering, Trichy, Tamilnadu, India, Mail id: [dharneeshkalai@gmail.com](mailto:dharneeshkalai@gmail.com)

<sup>5</sup>Department of Electrical and Electronic Engineering, Saranathan College of Engineering, Trichy, Tamilnadu, India, Mail id: [manojkumar7622502@gmail.com](mailto:manojkumar7622502@gmail.com)

<sup>6</sup>Department of Electrical and Electronic Engineering, Saranathan College of Engineering, Trichy, Tamilnadu, India, Mail id: [kalaiaraangopal820@gmail.com](mailto:kalaiaraangopal820@gmail.com)

<sup>7</sup>Department of Electrical and Electronic Engineering, Saranathan College of Engineering, Trichy, Tamilnadu, India, Mail id: [surendran1819@gmail.com](mailto:surendran1819@gmail.com)

**Abstract**— Herein, a venture is contrived and executed with Multilevel Cascaded Boost converter fed Multilevel Inverter. This paper comes up with two grades, one specifies Multilevel Cascaded Boost Converter and other is Cascaded H-Bridge inverter. The Multilevel Cascaded Boost converter changes the single DC input into five stages and H-Bridge inverter converts DC output from converter into an AC. The output voltage stages of the converter can be enhanced by including capacitor and diode in the output terminal. This paper manages the machination and persistent state investigation of converter and inverter and the simulation have been performed exploiting MatLAB/Simulink.

**Keywords-** *Multilevel Converter; Cascaded Boost Converter; voltage multiplier cell; H-Bridge Inverter and Level Circuit.*

## I. INTRODUCTION

For the time being, the fossil fuels generate worry due to the fact that they are not persistent and will eventually shrink, became too expensive day by day and are environmentally damaging to reclaim. Besides the fossil fuels like coal, oil, natural gases are producing a risky effect and polluting the environment which are responsible for the climatic changes. Hence the renewable energy resources are becoming high attraction encompassed by the renewable energy resources. The photovoltaic power gaining the big league in future. Due to the captivating facts like pure, no charge of emission, and less maintenances. In many countries Photo Voltaic system are getting a rapid growth in domestic as well as in industrial applications. One big challenge is to afford an incorporation of DC low voltage PV module to utility grid. As a method to increase the available power a topology called Multilevel Converters are employed. This paper, a Novel topology called Multilevel Cascaded Boost Converter has been introduced to maximize the power obtained from the PV module.

# SINGLE PHASE MULTILEVEL INVERTER BASED ON A NOVEL SWITCHING SCHEME USING BUCK CONVERTER

Paranthagan.B<sup>1</sup>, Vijayalakshmi.S<sup>2</sup>, Marimuthu.M<sup>3</sup>, Vijay.R<sup>4</sup>, Satheesh.R<sup>5</sup>

<sup>1</sup>Department of Electrical and Electronics Engineering, Saranathan College of Engineering, Trichy, Tamilnadu, India, Mail id: [paranthagan-eee@saranathan.ac.in](mailto:paranthagan-eee@saranathan.ac.in)

<sup>2</sup>Department of Electrical and Electronics Engineering, Saranathan College of Engineering, Trichy, Tamilnadu, India, Mail id: [bksvijji@gmail.com](mailto:bksvijji@gmail.com)

<sup>3</sup>Department of Electrical and Electronics Engineering, Saranathan College of Engineering, Trichy, Tamilnadu, India, Mail id: [marimuthueeephd@gmail.com](mailto:marimuthueeephd@gmail.com)

<sup>4</sup>Department of Electrical and Electronics Engineering, Saranathan College of Engineering, Trichy, Tamilnadu, India, Mail id: [vijay-eee@saranathan.ac.in](mailto:vijay-eee@saranathan.ac.in)

<sup>5</sup>Department of Electrical and Electronics Engineering, Saranathan College of Engineering, Trichy, Tamilnadu, India, Mail id: [satheesh-eee@saranathan.ac.in](mailto:satheesh-eee@saranathan.ac.in)

**Abstract**— This paper presents a single phase multilevel inverter (MLI) based on a novel switching scheme. This new design produces a substantial decline in the count of power devices and capacitors required to implement a multilevel output battery-powered application. The proposed scheme has two stages namely, DC-DC converter and Inverter. Multilevel are achieved for the inverter by altering duty cycle of the DC-DC converter. In the MATLAB/SIMULINK setting, the proposed idea was implemented and the outcomes were validated.

**Keywords**- DC-DC Converter, Buck Converter, Multilevel Inverter, MATLAB

## I. INTRODUCTION

Due to the benefits of high power waveforms, less harmonic distortion, low common mode voltage, low switching operations, medium, high-voltage and high power capacity, multilevel inverters have become popular in recent years. Usually, an inverter is a system that uses certain electronic circuits to transform DC electrical power into AC type.

Buck converters can be highly efficient (often greater than 90%), making them helpful for tasks such as converting a computer's main (bulk) supply voltage (often 12 V) down to lower USB, DRAM and CPU voltages.. Buck converters are used in self-regulating power supplies and advanced telecom and data-com systems

Generally, a simple inverter provides 2 or 3 output voltage levels. But the multilevel inverter produces 5 levels of output voltage or more. As compared to a 2 stage inverter, it generates a stepped output voltage with reduced harmonic distortion. It offers higher levels of output voltage and power. The inverter requires a fixed dc voltage that can be extracted from the converter.

The multilevel inverter, correlated with lower output harmonics, provides high power capability. Their main downside is their complexity, which includes a large number of power devices and passive parts, as well as a very complex control circuit.

# Symmetric Multilevel Inverter Using DC-DC Zeta Converter

S.Srinithi  
Department of Electrical and  
Electronics Engineering  
Saranathan College of Engineering  
Trichy, India  
ssrinithiselvi@gmail.com

Dr.S.Vijayalakshmi  
Department of Electrical and  
Electronics Engineering  
Saranathan College of Engineering  
Trichy, India  
bksvijji@gmail.com

M.Marimuthu  
Department of Electrical and  
Electronics Engineering  
Saranathan College of Engineering  
Trichy, India  
marimuthueeephd@gmail.com

B.Parathagan  
Department of Electrical and  
Electronics Engineering  
Saranathan College of Engineering  
Trichy, India  
parathagan-eee@sarathan.ac.in

**Abstract**— This paper presented is an attempt to suggest a high-gain Zeta converter with a voltage multiplier cell is fed with multilevel H-Bridge inverter. A perfect mixture of a slightly modified version of the regular Zeta converter and a voltage multiplier unit is the proposed circuit. The voltage addition of the suggested refitted zeta enhances the voltage gain by increasing n time of the multiplier unit. The proposed converter decreases the voltage issue over the transition, which concludes the superior output and the gain is improved without disrupting the primary circuit. In inverter to use minimum switches and get M-level output. The thorough study of the proposed converter with numerical analysis is now achieved with the help of MatLAB/Simulink.

**Keywords**— Multilevel Zeta (MLZ), Voltage-Multiplier unit (VMU), H-Bridge inverter.

## I. INTRODUCTION

DC to DC converters are the circuits that transform direct current sources to another voltage level by adjusting the duty cycle of the main circuit switches. These converters are commonly used in power distribution systems, dc motor drive applications and switched mode dc power system. Now a day it can be used in the maximum power point tracking in PV panel like a buck-boost converter. The Zeta converter design is identical to the SEPIC converter. The advantages of Zeta converter over the SEPIC converter are: 1. It has stable feedback loop even if the voltage range is wide it can provide a very good output voltage with relation. 2. Low output ripple, the output ripple of the Zeta converter is also lower than an equivalent SEPIC converter design. The multilevel Zeta converter is the combination of both conventional Zeta and the Voltage Multiplier Unit (VMU). The number of levels is easily added by the number of capacitors and diodes.

The excellence output voltage waveform depends on the number of inverter voltage level sand the number of output voltage level rises, the waveform become more sinusoidal [6]. To fulfill this requirement multilevel inverters are commonly used for their sinusoidal output wave. It is very challenging to get pure sine wave AC output with the use of

filter and it is very expensive, this can be easily achieved through multilevel inverter's (MLI) used. In MLI's are 1. Single source inverter 2.Multi source inverters. In our suggested circuit consists of single DC source only. This topology can be designed for both high and low power application. In the suggested scheme consists of two stages: the first is a multi-level DC-DC Zeta converter, which gives the DC output voltage value with the help of the VMU, get the N number of output levels, and the second one is the level circuit combine with H-Bridge inverter circuit, get the M level inverter outputs. Its actual details are seen in Fig.1.The M level stepped alternating current (AC) output voltage is easily obtained by only one DC source, with low number of power electronic components.

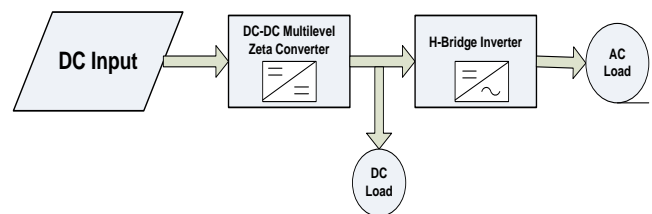

Fig. 1. Block diagram of proposed model

The main application of the MLI's are solar PV system, E-vehicles', auto mobiles, Fuel cells and Uninterrupted power supplies (UPS). Normal MLI's are complex structure need more input sources and stresses along the switches. In our suggested methodology simple in structure and used only one input source also reduced the switches stress. It is a symmetric MLI's DC source outputs are equal in magnitude.

## II. PROPOSED CONVERTER WITH INVERTER

The proposed model of DC-DC Zeta converter fed MLI's is illustrated in Fig. 2.

The Zeta converter is connected to the multiplier unit which is fed to the MLI via level switches. The DC-AC conversion is based on the Level circuit and the H-Bridge inverter.

# Non-isolated Multilevel Zeta Converter for MLI Application

Proceedings of International Conference on Power Electronics and Renewable Energy Systems pp 21-30 | Cite as

- Marikannu Marimuthu (1)
- Subramanian Vijayalakshmi (1)
- B. Paranthagan (2)
- R. Venugopal (3)
- S. Srinithi (4)
- B. Yuvaraj (5)
- R. Soundarajan (5)
- S. K. Vasantha Kumar (5)

1. Department of Electrical and Electronics Engineering, Saranathan College of Engineering, , Trichy, India

2. Associate Professor, Department of Electrical and Electronics Engineering, Saranathan College of Engineering, , Trichy, India

3. Assistant Professor, Department of Electrical and Electronics Engineering, Saranathan College of Engineering, , Trichy, India

4. PG Scholar, Department of Electrical and Electronics Engineering, Saranathan College of Engineering, , Trichy, India

5. UG Student, Department of Electrical and Electronics Engineering, Saranathan College of Engineering, , Trichy, India

Conference paper

First Online: 22 November 2021

- 64 Downloads

Part of the [Lecture Notes in Electrical Engineering](#) book series (LNEE, volume 795)

## Abstract

A new multilevel zeta converter which converts fixed DC voltage to multilevel DC output voltage is discussed in this paper. Proposed converter has stable voltage feedback capacity and produces high gain output voltages with less input current. Voltage supplied by the PV panel or the fuel cell is at an output of a low voltage. These output voltages can be interfaced with standalone (or) grid connected inverter system by employing the proposed converter. By using a single transistor with the multilevel capacitor geometric structure, the proposed converter is able to generate an output voltage that is much higher and has ripple free output current with a higher step-up conversion ratio. It allows for operation at much higher frequencies for a much longer



# Execution of PV supported Wet Processor with Improved performance for Domestic Application

K.Kalyani<sup>1</sup>, R.Balasubramanian<sup>2</sup>, M.Marimuthu<sup>3</sup>, B.Paranthagan<sup>4</sup>, K. Ramash Kumar<sup>5</sup>

PG Scholar, Department of EEE, Saranathan College of Engineering, Trichy, India<sup>1</sup>

Associate professor, Department of EEE, Saranathan College of Engineering, Trichy, India<sup>2</sup>

Assistant Professor, Department of EEE, Saranathan College of Engineering, Trichy, India<sup>3</sup>

Associate Professor, Department of EEE, Saranathan College of Engineering, Trichy, India<sup>4</sup>

Professor, Department of EEE, Karpagam College of Engineering, Coimbatore, India<sup>5</sup>

**Abstract:** This paper is exhibited for running of solar based wet processor using Photovoltaic frameworks and due to absence of battery it will perform at minimum cost and aims to holds out the DC source which step up from the PV panel and concatenate to an inverter to give an AC outcome and coupling of motor to the wet processor is driven by an Inverter. Perturb and Observe (P&O) calculation based Maximum Power Point Tracker (MPPT) utilized for enhancing productivity of the framework and by accomplishing a compelling PV based wet grinding system without a need for storage purpose. The outcomes are exhibited on accessibility of solar irradiance and simulation result comes about by utilizing MATLAB/SIMULINK which predicts the Open and closed loop system model.

**Keywords-** Photovoltaic (PV), Boost Converter, perturb and observe (P&O), Maximum power point tracker (MPPT), Induction motor.

## I. INTRODUCTION

Sun oriented energy is the most ease, widespread wellspring of energy as daylight's all through. Sunlight based energy changed over into electrical energy helpfully by photovoltaic innovation. Including boards are expanded the introduced control in the PV framework it can be alluring highlights of PV innovation. Among the numerous uses of PV energy, pounding is the most encouraging. In the framework, when daylight is accessible sun oriented energy are put away. Crushing to remote home are met from the sun oriented based wet Grinder. The majority of the PV frameworks are associated specifically to the DC motor. Sun oriented. fueled wet processor worked with AC drive utilizes an inverter with air conditioning motor. Acceptance motor offer capacity to pick as far as toughness, productivity, size, and viability.

Supported the DC control from sun based exhibit and sustained to an inverter which gives air conditioning. Motor are coupled to the Grinder which drive by air conditioning yield from inverter. Photovoltaic power framework generally influence vital of most extreme input to point following (MPPT) controller, which is an electronic framework that works the Photovoltaic (PV) modules to enables the modules to create all the power they will accomplish a predetermined thing [1]. MPPT calculations

are distinctive writes like as Perturbation and Observation (P&O) Method, incremental conductance strategy and so forth. There are preferences in avoid utilization of vast banks of lead corrosive batteries, which are overwhelming, expensive and have one fifth of lifetime of PV board[4]. Various item utilize dc motor driven in a few sections of the world, however they experience the ill effects of procedure of protecting a condition because of the nearness of the commutator and brushes.

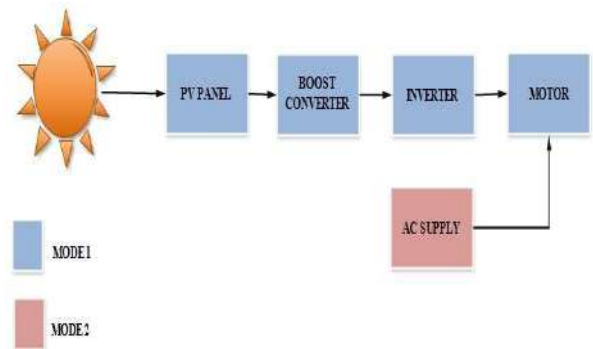

Fig.1 Basic Block Diagram

Fig.1 shows the block diagram of this proposal. It comprises of Solar board, support converter, MPPT controller, inverter, Load. Voltage sensor and current sensor used to detect the voltage and current from the board. MPPT controller acquires the info voltage and current from the board. These qualities can be advance agreeing into the MPPT calculation to track the Maximum power purpose of sun oriented board. The contribution to DC-DC converter from the yield of MPPT square is utilized as which might be voltage parameter or obligation cycle.

The working voltage keeping up at the Maximum power point with help of DC-DC converter. By changing the obligation cycle of DC -DC converter. In this paper advance up the working voltage at the most extreme power point utilizing Boost converter. Between the suns powered board and load DC-DC control converter are associated. The MPPT piece are heart of the model which finding the Maximum working purpose of sun powered board [1]. It gives gating sign to Boost converter to Maintains the working voltage at the most extreme working point regardless of temperature and sun oriented irradiance.

# Automatic Solar Based Grass Cutter

## Saranathan College Of Engineering, Trichy

### “Department Of Electrical Engineering”

V. Kavya, R. Meenachi, S. Mahalakshmi  
Guided by R. Balasubramanian, Associate Professor

**Abstract-** This paper is based on survey of identification of classification of solar based grass cutter. The solar grass cutter is a fully automated grass cutting robotic vehicle powered by solar energy that also avoids obstacles and is capable of fully automated grass cutting without the need of any human interaction. The system uses two 6V batteries to power the vehicle movement motors as well as the grass cutter motor. We also use a solar panel to charge the battery so that there is no need of charging it externally. The grass cutter and vehicle motors are interfaced to a microcontroller that controls the working of all the motors. It is also interfaced to an ultrasonic sensor for object detection. The micro-controller moves the vehicle motors in forward direction in case no obstacle is detected. On obstacle detection the obstacle sensor monitors it and the micro-controller thus stops the grass cutter to avoid any damage to the object. Micro-controller then turns the robotic movement as long as it gets clear of the object and then moves the grass cutter in forward direction again.

**Keywords** - Autonomous Area coverage, Lawn availability, Path planning, Robotic.

## INTRODUCTION

Grass cutter machines have become very popular today. Most of the times, grass cutter machines are used for soft grass furnishing. In a time where technology is merging with environmental awareness, consumers are looking for ways to contribute to the relief of their own carbon footprints. Pollution is man-made and can be seen in our own daily lives, more specifically in our own homes. Herein, we propose a model of the automatic grass cutting machine powered through solar energy, (nonrenewable energy). Automatic grass cutting machine is a machine which is going to perform the

grass cutting operation on its own. This model reduces both environment and noise pollution. Our new design for an old and outdated habit will help both customer and the environment. This project of a solar powered automatic grass cutter will relieve the consumer from mowing their own lawns and will reduce both environmental and noise pollution. This design is meant to be an alternate green option to the popular and environmentally hazardous fuel powered lawn mower. Ultimately, the consumer will be doing more for the environment while doing less work in their daily lives. The hope is to keep working on this project until a suitable design can be implemented and then be ultimately placed on the market. Moving the grass cutters with a standard motor powered grass cutters is an inconvenience, and no one takes pleasure in it. Cutting grass cannot be easily accomplished by elderly, younger, grass cutter moving with engine create noise pollution due to the loud engine, and local air pollution due to the combustion in the engine. Also, a motor powered engine requires periodic maintenance such as changing the engine oil. Even though electric solar grasses are environmentally friendly, they too can be an inconvenience. Along with motor powered grass cutter, electric grass cutters are also hazardous and cannot be easily used by all. Also, if the electric grass cutter is corded, mowing could prove to be problematic and dangerous. The prototype will also be will be charged from sun by using solar panels.

## Existing System

Now a day's pollution is a major issue for whole world. Pollution is manmade and can be seen in own homes. In case gas powered lawn movers due to the emission of the gases it is responsible for pollution. Also the cost of the fuel is increasing. Hence it is not efficient. The solar powered lawn cutters are introduced. Solar powered lawn mower can be described as the application of solar energy to power

# Transformerless Inverter Topology for Single Phase Application with Elimination of Leakage Current

**K.Rajkumar<sup>1</sup>, Manikandan.R<sup>2</sup>, Sethulakshmanan.N<sup>2</sup>, Nidhish.T<sup>2</sup>, Prasanth.M<sup>2</sup>**

<sup>1</sup>Assistant Professor, Department of Electrical and Electronics Engineering, Saranathan College of Engineering, Tiruchirappalli, Tamilnadu, India. [avk.rajkumar@gmail.com](mailto:avk.rajkumar@gmail.com)

<sup>2</sup>Scholar, Department of Electrical and Electronics Engineering, Saranathan College of Engineering, Tiruchirappalli, Tamilnadu, India.

<sup>2</sup> [tr.mani15@gmail.com](mailto:tr.mani15@gmail.com) , [smartsethu98@gmail.com](mailto:smartsethu98@gmail.com) [nidhiships@gmail.com](mailto:nidhiships@gmail.com) , [jeevaprasanth99@gmail.com](mailto:jeevaprasanth99@gmail.com)

## ABSTRACT

Various disadvantages such as increased weight, size and cost of single phase photovoltaic converter with transformer has urged the design engineers towards to the transformerless topologies. But, the main challenge of transformer less inverter topology is leakage current. In recent years, many leakage current reduction techniques have been addressed. Many of them are of galvanic isolation. Nevertheless the galvanic isolation can not only results the constant value of common mode voltage (CMV). Hence, it is not possible to achieve complete leakage current elimination. In this work, a transformerless single phase inverter with a clamping method is proposed to obtain constant CMV in all its operating modes. Additionally, a modified modulation approach is also proposed to enable a current path during the negative region of power. Consequently, it is possible to achieve reactive power region by the enabled bidirectional current path in the negative region of power. The result shows the complete clamping of the CMV and reactive power generation by the proposed system. Improved efficiency and reduction of harmonic distortions is also achieved.

**Key words:** CMV, Leakage current, PV, Power system; Reactive power; SiC, Transformerless Inverter; WBG.

## 1. INTRODUCTION

It is observed from the literature survey, various topologies of transformerless inverters have been dealt by numerous researches [1, 2, 3, 4]. Main demerit of transformerless inverters is its leakage current flow in absence of transformer. More leakage current flow increases total harmonic distortion (THD), electromagnetic interference (EMI) and thus escalates the overall system losses. In some cases, it may bring about personal safety issues [5]. In many transformerless inverter topologies, the efficiency has been increased by using unipolar modulation technique, thereby reducing the leakage current by truncating the AC side from DC side during the

freewheeling operation. This is just the well-known galvanic isolation approach.

Using this approach, various topologies have been introduced inclusive of famous HERIC inverter, H5 inverter and H6 inverter topologies [6, 7]. Since the CMV is unidentifiable by the operating modes, it is very important to note that the galvanic isolation alone cannot mitigate the leakage current. Therefore, modifications are required in modulation techniques and converter topologies as well.

Generally, obtaining unity power factor operation is being the primary objective of modulation techniques. As the grid connected operation of inverters require the reactive power generation as a desirable factor, the bipolar modulation techniques used to generate reactive power increase the switching losses and pull down the efficiency.

From [8, 9], it is found that Si MOSFET based transformerless inverter gives higher efficiency in reactive power generation, but there is a possibility of device failure because of inferior reverse recovery characteristics of Si MOSFET. The main aim of these inverters is to reduce the cost by avoiding complexity due to antiparallel conduction of diode. However, SiC MOSFET yields better performance on its reverse recovery due to shorter life time of its minority carrier [9, 10, 11].

For this reason, SiC MOSFET helps to generate the reactive power neither by modifying the structure of converter nor by increasing the number of freewheeling diodes. Due to the above fact, the wide band gap (WBG) power device, say SiC MOSFET is used in this work in order to offer the reactive power without any structural modification in the converter. Besides, lower THD and higher efficiency is achieved by operating the converter at 100 kHz switching frequency.

## 2. TOPOLOGY TO ELIMINATE THE LEAKAGE CURRENT

The novel inverter topology introduced in this work is derived from the regular H6 topology where the sixth switch has been



# Application of firefly algorithm for power estimations of solar photovoltaic power plants

Rajkumar K<sup>a</sup> and Kevin Ark Kumar <sup>b</sup>

<sup>a</sup>Department of EEE, Saranathan College of Engineering, Tiruchirappalli, India; <sup>b</sup>High Pressure Boiler Plant, Bharat Heavy Electricals Limited, Tiruchirappalli, India

## ABSTRACT

Modeling of solar photovoltaic cell is an essential requirement in the computations involved in solar photovoltaic power systems. Some metaheuristic algorithms are used for determining the cell parameters in the literature, however, more investigation is required with reference to varying solar irradiation and temperature to improve the accuracy of the models. Hence, this paper proposes firefly algorithm for identification of the cell parameters accurate enough to construct the cell characteristics under varying solar irradiation and temperature conditions. Experimental results obtained at standard irradiation and temperature of 1000 W/m<sup>2</sup>, 25°C, and at other irradiation levels such as 800 W/m<sup>2</sup> and 600 W/m<sup>2</sup>, temperature levels such as 40°C and 50°C were presented along with simulated values. The value of series resistance, shunt resistance and diode ideality factor for temperatures from 20°C to 60°C and irradiation of 400 W/m<sup>2</sup> to 1000 W/m<sup>2</sup> are computed using this proposed method. A comparison of the proposed method with other researchers at irradiation of 1000, 800, and 600 W/m<sup>2</sup> and 25°C was provided. The results of implementation show that there is a good agreement between computed values and data sheet values. The proposed method will definitely be useful for large scale solar photovoltaic designers, researchers, simulators.

## ARTICLE HISTORY

Received 9 June 2019

Revised 6 April 2021

Accepted 8 April 2021

## KEYWORDS

Solar photovoltaic; firefly algorithm; estimation; ideality factor; PV cell; cell modeling

## Introduction

Solar photovoltaic systems attracted many users due to its simple construction, eco-friendliness, noiseless operation and reliability. The government schemes of various nations have promoted solar power plants through various incentives and subsidies (Osorio-Aravena et al., 2021). The main question arising in the minds of investors is the techno-economic feasibility (Zhongqun et al., 2021) and the power output during various seasons (Jeong et al., 2020). The daily power generation from the solar power plants are estimated using several methods in the literature and more specifically using stochastic algorithms. There are plenty of day-ahead prediction models estimating the power generation using historical data. In (Ayan and Toylan 2020) artificial neural network was used to predict solar parameters and the performance are proved to be significantly better and similarly analog ensemble method was used in (Zhang et al., 2019) and a data-driven approach was used in (Abuella and Chowdhury 2018) for accurate power forecasting. However, analytical models of power plant yields better results in the majority of the cases. Though the models for electrical components such as dc-dc converters, dc-ac inverters etc. are well established, the model for PV cell is also an essential component that is being explored by several researchers today. Also, for the successful design and implementation of solar photovoltaic (PV) power system, a model of photovoltaic cell is mandatory.



# A carrierless pulse-width modulation strategy for three-phase cross-switched multilevel inverter using area equalization method

Rajkumar Kuppapillai<sup>1</sup> · Thamizharasan Sandirasegarane<sup>2</sup> · Krishnakumar Chittibabu<sup>1</sup>

Received: 8 July 2021 / Accepted: 18 November 2021  
© The Author(s), under exclusive licence to Springer-Verlag GmbH Germany, part of Springer Nature 2021

## Abstract

Multilevel inverters (MLI) are preferred for high voltage, medium power applications due to their ability to synthesize the stepped waveform nearly to a sinusoidal voltage. However, it has several issues like, increased number of devices, higher blocking voltage and power loss in higher voltage levels. Additionally, the traditional pulse-width modulation (PWM) applied to MLI is simply an extension of three-level inverter PWM and it becomes cumbersome at higher voltage levels. Therefore, this research article proposes a PWM strategy without carrier and reference signals. This concept equates the area under target fundamental output voltage to that of actual output voltage. In the proposed PWM strategy, a mathematical model is developed to compute the position of the pulse and the width of the pulse using centroid technique and equal area criteria, respectively. The proposed strategy is generalized to any preferred levels with reduced complexity in implementation. The simulation results of the proposed strategy showcase better performance indices. Gate pulses are generated by Xilinx Spartan 3E FPGA controller in experimentation. The experimental investigation of the three-phase five-level inverter prototype gives the results confirming the capabilities of the proposed strategy in real-time applications.

**Keywords** Area equalization · Multilevel inverter · Centroid technique · FPGA · PWM

## 1 Introduction

The emergence of multilevel inverters makes helpful in supplying high power and medium voltage industrial applications which fits its use broadly in domestic needs. Several researches have been put forth to develop dedicated modulation strategies for particular topologies or to bring an amalgamation in traditionally tailored control strategies to operate the topologies for level synthesizer with the aim of good performance indices. On the basis of carrier phase disposition PWM (PDPWM), Zhao et al. [1] developed a higher and lower carrier cells alternative phase opposition PWM for the hybrid-clamped multilevel inverter constructed by reduced number of devices. This strategy claims to operate over a broad range of modulation indices, reduced switching losses and lower amplitude of lower harmonics. Zhang and

Lum [2] introduced a novel pulse-width modulation scheme in flying-capacitor asymmetric H-bridge inverter with the positive and negative cross-carriers to control the flying-capacitor voltage by utilizing the redundant switching states of the output voltages and three modes of pre-charging the flying capacitor without extra equipments. The capacitance of the flying capacitor and the switching frequency of the power switches are selected based on the allowable voltage fluctuation across the flying-capacitor and the load current. A novel minimized loss DPWM method is developed by varying the offset based on peak values of three-phase load currents and as a result of avoiding commutations at high currents with reduced switching loss for multilevel inverters [3]. A generalized pulse-width modulation approach developed within the carrier-based PWM by Grigoletto and Pinheiro [4] to eliminate both the low-frequency oscillations and imbalances of the dc-link capacitor voltages in four or more level diode clamped multilevel inverters. The four different sequential switching hybrid-modulation strategies comprised of fundamental-frequency modulation and multilevel sinusoidal-modulation (MSPWM) strategies for cascaded multilevel inverters are developed in [5], with the characteristics of the reduced switching losses, good har-

✉ Rajkumar Kuppapillai  
avk.rajkumar@gmail.com

<sup>1</sup> Department of Electrical and Electronics Engineering, Saranathan College of Engineering, Tiruchirappalli, India

<sup>2</sup> School of Engineering and Technology, Surya Group of Institutions, Vikiravandi, India

# DESIGN OF SEPIC CONVERTER FOR RENEWABLE ENERGY APPLICATIONS

J.SHERRIN BANU <sup>[1]</sup>, DR.S.VIJAYALAKSHMI<sup>[2]</sup>,M.MARIMUTHU<sup>[3]</sup>

*PG Scholar, Dept. Of EEE, Saranathan College Of Engineering, Trichy, India<sup>[1]</sup>*

*Associate Professor, Dept. Of EEE, Saranathan College Of Engineering, Trichy, India<sup>[2]</sup>*

*Assistant Professor, Dept. Of EEE, Saranathan College Of Engineering, Trichy, India<sup>[3]</sup>*

**Email id:** sherrinbanu2@gmail.com

## ABSTRACT

Design of the power electronics circuitry are now -a-days reducing the size, space and weight of the converter/ inverters circuits. This is possible because of the availability of new high switching frequency devices. This paper represents the analysis performance of SEPIC converter for renewable energy applications. This converter is used in buck as well as in boost mode.

The SEPIC converter is designed, analyzed and simulated. The proposed model of the SEPIC converter consist of two parts: (i) main converter components like switch, Inductors, Diodes, Capacitors, and a Load.,(ii) a control circuit for controlling the duty cycle using ARDIUNO .

To verify the proposed model, the circuit is prepared and their experimental results were compared with the results obtained by simulation of the circuit in PROTEUS and MATLAB.

## KEYWORDS :

SEPIC converter ,switch, inductors, diodes, capacitors, and a load, duty cycle, ARDIUNO, PROTEUS, MATLAB.

THE DC-DC converter is a dc power supply that is small, light in weight and highly efficient and uses a semiconductor switching elements. It can respond quickly and suitable to change in input voltage. The dc input voltage to the converter is assumed to have zero internal impedance. The SEPIC is a type of DC-DC converter allowing voltage at its output to be either greater than or lesser than or equal to its input voltage. The output voltage of the converter is controlled by controlling the duty cycle of the MOSFET.

A Sepic converter is a Boost converter followed by a buck boost converter, but has advantage of having the output voltage polarity same as that of the input voltage .a coupling capacitor transfers the energy from the input to output . During ON time the diode is reverse biased due to negative polarity of coupling capacitor and inductor  $L_2$  and inductor  $L_1$  is charged through source and coupling capacitor is discharged.

During OFF time the switch  $L_1$  charged coupling capacitor and  $L_2$  transfers energy to the output diode is forward biased in this case.

## I.INTRODUCTION

## II. ANALYSIS OF SEPIC CONVERTER

# MODELLING AND SIMULATION OF HYBRID (WIND and SOLAR) FOR DC MICROGRID

S.Priya

*PG Student, Dept Of EEE,*

Saranathan College Of Engineering, Trichy,

E-Mail-priyamalathy13gmail.com

M.Marimuthu,

*Assistance prof, Dept Of EEE,*

Saranathan College Of Engineering, Trichy,

E-Mail-marimuthuoffice@gmail.com

S.Vijayalakshimi

*Associate prof, Dept Of EEE,*

Saranathan College Of Engineering, Trichy,

E-Mail-bksvijji@gmail.com

S. Prassanna Perumal,

*PG Student, Dept Of EEE,*

Saranathan College Of Engineering, Trichy,

E-Mail-prassannaex@gmail.com

## ABSTRACT:

This paper deals with the development of DC Micro grid using Hybrid Wind/Solar power system using MATLAB/SIMULINK. The hybrid of small modular device such as PV, small wind turbine and storage device and it given to DC load is known as DC microgrid. Wind/Solar hybrid power system is used to improve the energy efficiency and the LED'S are useful for power cost. LED'S are energy saving, high luminous efficiency and very much useful life. LED (Light Emitting Diode) street light system play an major role and run in DC power with the increased use of Hybrid power system, Since the irradiance of pv panel and speed of the wind turbine is variable this is controlled by power electronics device. Here buck and boost converter is used for both the energy. The proposed system was canvas in consider to the operation status of the hybrid input power and battery voltage using MATLAB simulation. The hybrid system is determined by simulating using MATLAB/SIMULINK.

**Keywords:** (Solar, Wind, Boost and Buck Converter, MPPT and PID controller, DC Microgrid)

## I. INTRODUCTION

In present day a huge problem in many countries is power demand, so we move to Renewable energy that we integrated the solar and wind energy. The global insight of renewable energy in power system is rapidly increasing for wind and solar energy system. Amount of solar power and wind power integration increases it can

be created technical challenges to the grid Power system due to solar and wind power is naturally sporadic. The size of the battery storage energy belong to intermittency level of the solar or wind .In summation if solar or wind are used to supply the power to a stand-alone system, energy storage system becomes essential to assure that power supply is continuous.

## A. WIND ENERGY

The popular field of technology is wind energy so it has many developments laying ahead the wind power industry is one of the fastest expanding industries as a result of rapid growth of installed capacity. In Fig.1 depicts the generation of Power using Windmill. This is the renewable energy sources for taken from wind mill. The generation of electricity from wind energy has less installation and maintenance. We can produce the energy almost 24 hours of the day. Initial cost also less for this kind of system.

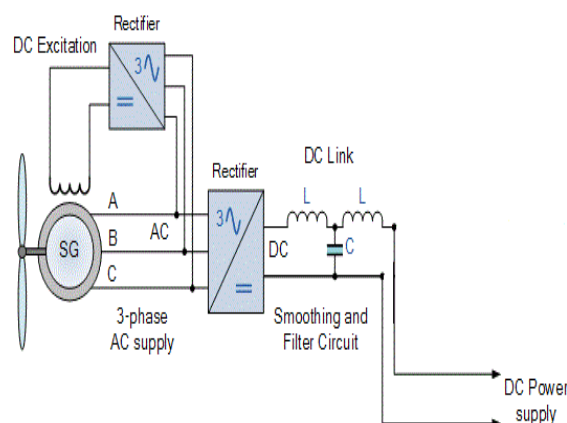

Fig. 1 Generation of power using Wind mill

# Design and Analysis Of Quadratic Boost Converter

M.Priyanga<sup>1</sup>, B.Paranthagan<sup>2</sup>, Dr.S.Vijayalakshmi<sup>3</sup>, M.Marimuthu<sup>4</sup>

PG Scholar, EEE, Saranathan College of Engineering, Trichy, India<sup>1</sup>  
 Associate Professor, EEE, Saranathan College of Engineering, Trichy, India<sup>2,3</sup>  
 Assistant Professor, EEE, Saranathan College of Engineering, Trichy, India<sup>4</sup>

**Abstract—** In this paper the simulation of a High gain DC-DC Quadratic Boost Converter is presented. Operation of the QBC is analyzed, leading to mathematical expressions that can be used to design a converter. Based on the derived analytical expressions, a 200W, QBC converter is designed. The proposed quadratic boost converter implemented in MATLAB/SIMULINK.

**Keywords—**DC-DC converter, Quadratic Boost Converter

## I. INTRODUCTION

In recent years for a great number of appliances dc-dc converter is employed. Normally in renewable energy system, the system having low output characteristics to recover this demand DC-DC converter topology is implemented. For maintaining the output DC voltage range in PV array and fuel cells, converter is wont to improve the output voltage. But during the switching operation the voltage stress is high. While selecting the converter the concentrating options are; once switch is activate it should attain the zero voltage crossing, when PhotoVoltaic array is connected to the grid the converter should ought to offer the high terminal voltage for low input vary. The converter which provides the high output vary at low voltage stress is a lot of economical. Voltage gain typically supported duty magnitude relation thus by selecting the passive parts components the duty magnitude relation can be restricted.

## II. QUADRATIC BOOST CONVERTER

The circuit diagram of a quadratic boost converter is shown in Fig1. The circuit comprises of a single switch S, three diodes D1, D2 and D3, two capacitors C1 and C2, two inductors L1 and L2 and a load resistor R. The circuit operation is entirely in view of the supposition that the switch S is perfect in operation and capacitors C1 and C2 is

thought to be substantial so the voltage over the capacitors VC1 and VC2 are almost consistent over an switching period. At the point when the switch is ON: The comparable circuit schematic of the QBC amid the ON state is appeared in Fig 2.when switch S is turned on D2 is forward one-sided, while D1 and D3 invert one-sided. Currents are provided to L1 and L2 by Vin furthermore, C1 respectively.

At the point when the turn is OFF: The method for operation and current stream heading of QBC amid OFF state is appeared in Fig 3. In this condition D1 and D3 are forward biased, while D2 switch is reverse biased. L1 and L2 are charging C1 and C2 individually. During this state, iL1 and iL2 is diminished.

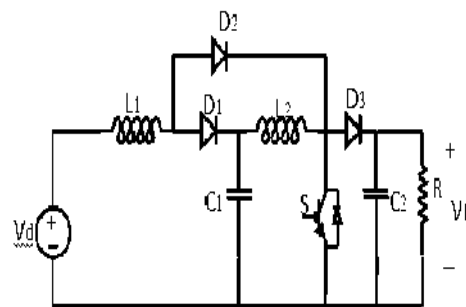

Fig1. Quadratic Boost Converter

## III. STEADY STATE ANALYSIS

Mode 1 (Switch S = on)

The equivalent circuit schematic of the QBC during the ON state is shown in Fig 3.6.when switch S is turned on D 2 is



# Analysis of PV Panel based Bidirectional Converter for Electric Vehicle

Vijayalakshmi S  
Department of EEE  
Saranathan college of Engineering,  
Trichy, India  
bksviji@gmail.com

Shivabalan N  
Department of EEE  
Saranathan college of Engineering,  
Trichy, India  
shivabalan1999@gmail.com

Thayananth.T  
Department of EEE  
Saranathan college of Engineering,  
Trichy, India

Marimuthu M  
Department of EEE  
Saranathan college of Engineering,  
Trichy, India  
marimuthueeephd@gmail.com

Shathishkumar VK  
Department of EEE  
Saranathan college of Engineering  
Trichy, India  
shathishgokul@gmail.com

Venugopal. R  
Department of EEE  
Saranathan college of Engineering,  
Trichy, India  
venugopal-eee@saranathan.ac.in

Pravinraj T  
Department of EEE  
Saranathan college of Engineering  
Trichy, India  
pravinprince1122@gmail.com

**Abstract - This paper present an analysis of PV panel based Bidirectional converter for Electric vehicle charging. This system consists of solar cell battery, bidirectional dc -dc converter. A Battery is provided for supply power to dc motor during no sunlight condition. The bidirectional dc-dc converter is working in both charging and discharging the battery and can manage the flow of power in both the direction and hence excess energy from the PV panel can be stored in battery. MPPT controller extract maximum power from the PV module under the impact of varying irradiance and varying the load conditions. Model Performance evaluation and analysis has been done through MatLAB/Simulink**

**Keywords : PV panel, Bidirectional Converter, battery, Maximum Power Point Tracking (MPPT).**

## I. INTRODUCTION

Solar energy becomes the most challenging energy sources. In fact, a lot of domestic & industrial or commercial applications use solar energy. Solar energy is a key source to reduce Co2 emissions. On our country, ICE (Internal combustion Engines) are a major source of pollution, hence Electric vehicles become the promising solution. For many reasons taking into account, environmental and cost considerations, renewable energy sources such as solar energy is preferable to charge plug-in electric vehicles. In India, mostly IC engines where used for the transportation. In order to reduce environmental pollution and climatic change and increasing price of fossil fuels, Indian government encourages to promotes more and more electrical vehicles (EV). The Indian government set a target to accelerate the adoption of Electrical vehicles to reduce pollution and many other advantages like high torque and easy speed control. However, all IC engines have to be replaced by an energy storage battery with the help of suitable converter.

In [1] the authors propose an AC charging station with second life Li-ion battery, integrating solar PV, and wind energy. This station is grid connected which allows the export or import energy depending on the utilization. The authors in [2], [4] a control strategy of a multi-port, grid connected, direct DC PV charging station was proposed, the source of energy here can be either PV panels or AC grid, the transfer of energy from AC grid is bidirectional, hence, PV

energy can be injected on AC grid. These two topologies use many converters, which reduce efficiency. In [5] a charging strategy is proposed to minimize the energy cost, the charging time is divided into intervals to minimize the peak consumption of a fleet of EVs during day time. The charging station in this case is grid connected; in addition, the topology was not given.

The effect of fast charging EVs on the AC grid was investigated in [8]: the charging station in [8] is a DC fast charging, and only the grid is used as energy source. The energy source is not renewable and the efficiency is decreased by using two converters. Four possible architectures for a solar EV charger are proposed and compared in [9], these configurations are also grid connected, two possible choices for interconnection to the AC grid: AC inter-connection or DC inter-connection. The efficiency is decreased by the use of several DC-DC and DC-AC converters.

Our proposed PV fed bidirectional converter for EV vehicle is illustrated in Figure 1. This block diagram consists of PV panel, bidirectional converter, battery, and E-bike. The power from PV panel is irregular in nature, so when solar power generation is higher than the demand of the load, then the surplus energy is served to the battery station via bidirectional converter. Any time when the load demand goes beyond the instantaneous solar power generation, the shortfall of power demand is supplied by the station battery through the converter. When the absence of solar power, the battery power is transferred to the load through bidirectional converter. This study can be done for 1KW Solar charging station to charge electric bikes. P&O algorithm has been used in our system for implementing MPPT, due to its simplicity and less computational demands. Also, no prior knowledge of the PV system is necessary for the algorithm to work. The sun has been playing numerous roles in humane existence.

In this paper, section 2 consists of proposed circuit, section 3 contains simulation circuit and results discussion are carried out in section 4, finally section 5 consists of conclusion.

# A Novel Isolated DC-DC Multi-Level Flyback Converter for Multi-Level Inverter Application

Venugopal R  
Department of Electrical and  
Electronics Engineering  
Saranathan College of Engineering  
Trichy, India  
venugopalramadoss@gmail.com

Dr. Vijayalakshimi S  
Department of Electrical and  
Electronics Engineering  
Saranathan College of Engineering  
Trichy, India  
bksviji@gmail.com

Marimuthu M  
Department of Electrical and  
Electronics Engineering  
Saranathan College of Engineering  
Trichy, India  
marimuthueephd@gmail.com

Chandra Kishore M  
Department of Electrical and  
Electronics Engineering  
Saranathan College of Engineering  
Trichy, India  
chandra.083.ck@gmail.com

Mohammed Rifat Z  
Department of Electrical and  
Electronics Engineering  
Saranathan College of Engineering  
Trichy, India  
rifatzahir@gmail.com

Niresh Shankar P  
Department of Electrical and  
Electronics Engineering  
Saranathan College of Engineering  
Trichy, India  
niresshine@gmail.com

**Abstract --- The main theme of this paper is to present a high voltage gain dc-dc boost converter using flyback and multilevel concept. The proposed converter focuses on multilevel outputs with voltage multiplier cell. The input of the general dc-dc converters is either PV array or battery or fuel cell. The circuit is composed of diodes and capacitors which acts as voltage multiplier and also as a rectifier. The implemented multilevel flyback converter can be connected to an H-bridge forming a multilevel inverter. With the help of a single driven semiconductor switch namely MOSFET, the designed converter can produce a high voltage gain in continuous conduction mode. The proposed multilevel flyback converter has been simulated and verified with theoretical values. The results have been demonstrated in the report.**

**Keywords --- Flyback Converter - Multilevel Flyback - Voltage Multiplier (VM).**

## I. INTRODUCTION

Intergovernmental Panel on Climate Change, regularly access the latest climate science reports for every country which is established in 1988. The earth's average temperature is rising at an unprecedented rate, causing rapid warming and climate changes in the contrary of fossil fuels like coal and petrol. Since 1973, various acts like Air act which aims to control the levels of air pollution through measures of National Ambient Air Quality Standards (NAAQS) and Motor vehicles Act (1988) is aimed to address the vehicular traffic and transportation of hazardous wastes. In order to reduce consumption of fossil fuels, solar cars comes into picture. Hybrid Solar vehicles and Commercial Solar Vehicles are replacing the conventional auto Mobiles. The Solar Vehicles requires a wide range dc input voltages for its operation so the demand for DC-DC Converters are in the rise. Isolated converter which has high voltage is combined with VM cell is implemented in this paper.

The flyback converter is a power supply topology that uses mutually coupled inductor or transformer to store energy. The flyback converters are similar to the booster converters in architecture and performance. However, the primary winding of the transformer replaces inductor while

the secondary provides the output. In the flyback configuration, the primary and secondary windings of transformer are utilized as two separate inductors. The basic flyback converter uses a relatively small number of components. A switching device chops the input DC voltage and the energy in the primary is transferred to the secondary through the switching transformer. A diode in the secondary rectifies the voltage while the capacitor boosts and removes the ripple.

A voltage multiplier is an electrical circuit with combination of capacitor and diode that converts AC electrical power from a lower voltage to a higher DC voltage. Voltage multiplier cells are very much similar to rectifier. Usage in electrical and electronic application such as in microwave ovens, strong electric field coils for cathode-ray tubes, electrostatic and high voltage test equipment, etc. The DC output voltage of a rectifier is limited to the peak value of its sinusoidal input voltage. While combining multiple diodes and capacitors as VM cells, we can effectively multiply the DC output voltage for some odd or even multiples.

## II. DESIGN AND OPERATION OF MULTILEVEL FLYBACK CONVERTER

The overall block diagram for the need of high gain converter is shown in fig 1. The ultimatum of the proposed converter is to design a multilevel flyback converter using voltage multiplier cells. This interlinking of flyback and VM makes it possible to develop any number of levels of output just by adding combinations of diodes and capacitors. The main topology is to terminate the limitation of output.

The circuit is going to be operated in continuous conduction mode. Hence an inductor which act as a filter is connected parallel in the primary side of transformer. The inductor is used to limit high input voltage. A single semiconductor switch N-channel MOSFET has been used to control the pwm. Arduino micro controller has been used to provide gate pulse to the MOSFET. The switching frequency implemented is 50 kHz. The converter can operate in extremely high frequencies and so smaller value of inductor is enough. The circuit diagram has been shown in fig 2.

# Symmetric Multilevel Inverter Using DC-DC Zeta Converter

S.Srinithi

Department of Electrical and  
Electronics Engineering  
Saranathan College of Engineering  
Trichy, India  
ssrinithiselvi@gmail.com

Dr.S.Vijayalakshmi

Department of Electrical and  
Electronics Engineering  
Saranathan College of Engineering  
Trichy, India  
bksvijji@gmail.com

M.Marimuthu

Department of Electrical and  
Electronics Engineering  
Saranathan College of Engineering  
Trichy, India  
marimuthueeephd@gmail.com

B.Parathagan

Department of Electrical and  
Electronics Engineering  
Saranathan College of Engineering  
Trichy, India  
parathagan-eee@sarathan.ac.in

**Abstract**— This paper presented is an attempt to suggest a high-gain Zeta converter with a voltage multiplier cell is fed with multilevel H-Bridge inverter. A perfect mixture of a slightly modified version of the regular Zeta converter and a voltage multiplier unit is the proposed circuit. The voltage addition of the suggested refitted zeta enhances the voltage gain by increasing n time of the multiplier unit. The proposed converter decreases the voltage issue over the transition, which concludes the superior output and the gain is improved without disrupting the primary circuit. In inverter to use minimum switches and get M-level output. The thorough study of the proposed converter with numerical analysis is now achieved with the help of MatLAB/Simulink.

**Keywords**— Multilevel Zeta (MLZ), Voltage-Multiplier unit (VMU), H-Bridge inverter.

## I. INTRODUCTION

DC to DC converters are the circuits that transform direct current sources to another voltage level by adjusting the duty cycle of the main circuit switches. These converters are commonly used in power distribution systems, dc motor drive applications and switched mode dc power system. Now a day it can be used in the maximum power point tracking in PV panel like a buck-boost converter. The Zeta converter design is identical to the SEPIC converter. The advantages of Zeta converter over the SEPIC converter are: 1. It has stable feedback loop even if the voltage range is wide it can provide a very good output voltage with relation. 2. Low output ripple, the output ripple of the Zeta converter is also lower than an equivalent SEPIC converter design. The multilevel Zeta converter is the combination of both conventional Zeta and the Voltage Multiplier Unit (VMU). The number of levels is easily added by the number of capacitors and diodes.

The excellence output voltage waveform depends on the number of inverter voltage level sand the number of output voltage level rises, the waveform become more sinusoidal [6]. To fulfill this requirement multilevel inverters are commonly used for their sinusoidal output wave. It is very challenging to get pure sine wave AC output with the use of

filter and it is very expensive, this can be easily achieved through multilevel inverter's (MLI) used. In MLI's are 1. Single source inverter 2.Multi source inverters. In our suggested circuit consists of single DC source only. This topology can be designed for both high and low power application. In the suggested scheme consists of two stages: the first is a multi-level DC-DC Zeta converter, which gives the DC output voltage value with the help of the VMU, get the N number of output levels, and the second one is the level circuit combine with H-Bridge inverter circuit, get the M level inverter outputs. Its actual details are seen in Fig.1.The M level stepped alternating current (AC) output voltage is easily obtained by only one DC source, with low number of power electronic components.

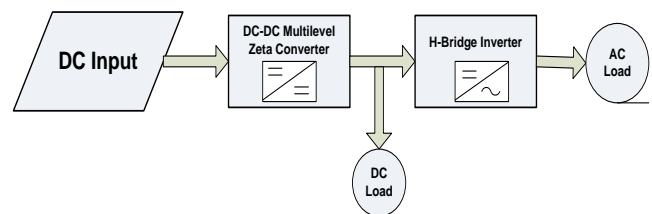

Fig. 1. Block diagram of proposed model

The main application of the MLI's are solar PV system, E-vehicles', auto mobiles, Fuel cells and Uninterrupted power supplies (UPS). Normal MLI's are complex structure need more input sources and stresses along the switches. In our suggested methodology simple in structure and used only one input source also reduced the switches stress. It is a symmetric MLI's DC source outputs are equal in magnitude.

## II. PROPOSED CONVERTER WITH INVERTER

The proposed model of DC-DC Zeta converter fed MLI's is illustrated in Fig. 2.

The Zeta converter is connected to the multiplier unit which is fed to the MLI via level switches. The DC-AC conversion is based on the Level circuit and the H-Bridge inverter.

# IMPLEMENTATION OF P & O ALGORITHM FOR MULTI LEVEL CASCADED- BOOST CONVERTER

Reka.J<sup>1</sup>, Vijayalakshmi.S<sup>2</sup>, Marimuthu.M<sup>3</sup>, Paranthagan.B<sup>4</sup>, Vijay.R<sup>5</sup>, Venugopal.R<sup>6</sup>

<sup>1</sup>Department of Electrical and Electronics Engineering, Cauvery College of Engineering, Trichy, Tamilnadu, India, Mail id: [reka.zenith@gmail.com](mailto:reka.zenith@gmail.com)

<sup>2</sup>Department of Electrical and Electronics Engineering, Saranathan College of Engineering, Trichy, Tamilnadu, India, Mail id: [bksvijji@gmail.com](mailto:bksvijji@gmail.com)

<sup>3</sup>Department of Electrical and Electronics Engineering, Saranathan College of Engineering, Trichy, Tamilnadu, India, Mail id: [marimuthueeephd@gmail.com](mailto:marimuthueeephd@gmail.com)

<sup>4</sup>Department of Electrical and Electronics Engineering, Saranathan College of Engineering, Trichy, Tamilnadu, India, Mail id: [paranthagan-eee@saranathan.ac.in](mailto:paranthagan-eee@saranathan.ac.in)

<sup>5</sup>Department of Electrical and Electronics Engineering, Saranathan College of Engineering, Trichy, Tamilnadu, India, Mail id: [vijay-eee@saranathan.ac.in](mailto:vijay-eee@saranathan.ac.in)

<sup>6</sup>Department of Electrical and Electronics Engineering, Saranathan College of Engineering, Trichy, Tamilnadu, India, Mail id: [satheesh-eee@saranathan.ac.in](mailto:satheesh-eee@saranathan.ac.in)

*Abstract*— Maximum power point (MPP) monitoring is an unavoidable feature of a solar (PV) array energy conversion system. Thus an attempt is made to implement the new multi-level cascaded boost converter for maximum power point tracking. MPPT plays a vital role in Photo Voltaic power system as they provides the maximum power output for PV System for different weather conditions and thereby gives improved array efficiency. The goal is accomplished here by implementing the Perturb & Observe MPPT algorithm, which also provides high voltage gain by the use of the proposed converter circuit. The MATLAB/SIMULINK is used for Testing and Implementing the required objective. The algorithms are implemented in m-file of MATLAB.

**Keywords:** *Photovoltaic Module, Multi Cascaded Boost Converter, MPPT Controller, Perturb and Observe method, PSIM.*

## I. INTRODUCTION

Environmental problems empower the world towards renewable energy production. The sunlight is the huge source of inexhaustible energy and the solar array are handled by the influence of the solar radiation, shading and temperature. Solar energy is effectively utilized by Photovoltaic System. The photovoltaic system is used to get the electrical energy from the PV system and restored in the battery

During the non-availability of solar energy, the battery storage system is used for supplying the power. The electric power obtain from solar panel is maximised using P&O algorithm by MPP Tracking. The DC-DC



# A Novel Non-isolated Single Switch Multilevel Cascaded DC–DC Boost Converter for Multilevel Inverter Application

M. Marimuthu<sup>1</sup> · S. Vijayalakshmi<sup>1</sup> · R. Shenbagalakshmi<sup>2</sup>

Received: 7 April 2020 / Revised: 9 June 2020 / Accepted: 22 July 2020  
© The Korean Institute of Electrical Engineers 2020

## Abstract

This paper presents a high gain non isolated Multilevel Cascaded Boost Converter (MCBC) for Electric vehicle applications. The proposed converter associates the basic cascaded Boost converter along with multilevel boost converter for boosting the voltages generated from different sources like solar energy, fuel cell and Battery. The multilevel boost converter is intended to be utilized as a dc link in which the high gain boosted voltage is provided to the multilevel inverter. By expending a single driven semiconductor switch and an inductor, the proposed converter is capable of producing high voltage gain with continuous input current and much higher step up conversion ratio. It not only allow to operate at much higher frequencies but aids in operating with a minimum duty cycle without a transformer. The proposed converter with five cascaded levels are simulated and is verified experimentally. The results thus illustrated go in concurrence with each other.

**Keywords** Boost converter · Multilevel cascaded boost converter · High voltage gain

## 1 Introduction

As per the United Nations report on climate change, the transportation sector majorly contributes towards the greenhouse gas emission. Even though India had made a Paris agreement in 2015 to reduce the emission, rigorous steps have to be taken in order to meet the unconditional commitments made in the Paris conference, 2015. The report further clarifies that the emission should be reduced by 55% lower than in 2018 so that the global warming would be limited to below 2 °C. The main reason for the increased emission from transport sector is due to the burning of petroleum products like petrol, diesel, CNG etc. It is also seen that after U.S. and China, India contributes more towards the emission

of Green House Gases leading to climate change. Hence there is a need for the modernized design of the Electric Vehicles which is one of the most promising alternatives for the conventional automobiles. The state of the art design of Electric vehicles leads to zero carbon emission vehicles which in turn results in “3Z” concept of zero poverty, zero unemployment and zero net carbon emission [1].

The hybrid electric vehicles and plug in hybrid electric vehicles are gaining popularity nowadays and a lot of researches are being conducted in order to develop a strong, robust and highly reliable hybrid energy storage scheme with immense power density, lesser price to weight ratio with longer life cycle. The Power Electronic Converters play a major role in controlling the power or current flow of such hybrid systems [2]. Since the hybrid electric vehicles use different power sources such as Battery, Fuel cells, Ultra capacitors and Ultrafly wheels, it is necessary that a robust and much more efficient dc–dc converter with high voltage conversion ratio is needed to boost up the available voltage from different sources into a desired regulated dc voltage. In [3] & [4] a highly efficient Boost converter is proposed in which a coupled inductor with three windings is manipulated so that high voltage gain is obtained and switching stress is also diminished. But the authors have not explicated the major limitations on the coupled inductors such as higher

✉ M. Marimuthu  
marimuthueeephd@gmail.com

S. Vijayalakshmi  
bksviji@gmail.com

R. Shenbagalakshmi  
Lakshmi\_amrith@yahoo.com

<sup>1</sup> Department of Electrical and Electronics Engineering,  
Saranathan College of Engineering, Trichy, Tamilnadu, India

<sup>2</sup> Department of Electrical and Electronics Engineering,  
SKN Sinhgad Institute of Technology & Science, Lonavala,  
Maharashtra, India

# Symmetric Multi-Level Boost Inverter with Single DC Source Using Reduced Number of Switches

Marikkannu MARIMUTHU\*, Subramanian VIJAYALAKSHMI

**Abstract:** In this paper a novel multilevel boost DC to DC converter with H-Bridge inverter circuit for single DC source is proposed. The proposed scheme has two stages: the first one is a multilevel boost converter which gives a multilevel dc output for a single dc source and the second level is a H-Bridge converter which converts multilevel DC to multilevel AC at required frequency. This DC-DC converter not only reduces the DC source but also reduces the switches, diodes and capacitors. This leads to decrease of the amount and the inverter space installation in order to increase the required output voltage by increasing the number of capacitors and diodes in the DC to DC converter. Comparison between the number of power switches for the suggested topology and other topologies in the recent literature is presented. Simulation results are conveyed through MatLAB/Simulink domain and the working of the suggested converter is realized.

**Keywords:** level circuit; multi-level boost converter (MBC); multi-level inverter (MLI); pulse width modulation (PWM); total harmonic distortion (THD)

## 1 INTRODUCTION

In order to achieve high boost ratios and excellent efficiency, there are several implemented boost topologies with transformer-less converter. In the conventional boost converter, the capacitor current is discontinuous resulting in larger capacitor size and EMI issues [1-5]. The MBC is the mixture of traditional boost DC-DC converter and the switched capacitor which works to provide different output voltages and a self-sustained voltage using one inductor, one switch,  $2M - 1$  ( $M$  - number of level) capacitors and  $2M - 1$  diodes for  $M^*$ MBC. It is a PWM based boost converter, where there are different required voltage levels with unidirectional current flow, and self-adjusting various level converters [6-11]. The main advantages of this converter are: it allows high switching frequency, a high gain beyond extreme duty cycle, continuous input current, and excludes transformer. Without modifying the main circuit, more levels of the converter should be achieved by adding diodes and capacitors. In order to achieve reduced switching losses, improved high voltage operation capability, less Electro Magnetic Interference (EMI), and high voltage gain, multilevel inverters are preferred.

To fulfill the demand of power rating and improved power quality with the reduced harmonic distortion, multilevel inverter is better than conventional inverter. Because the gate pulse used in the switches of MLI is high switching frequency PWM is recommended. Due to the easiness of the control and modularity the MLI is highly preferable to conventional inverter.

hard to get a pure sinusoidal AC output with the use of filters. It may increase overall cost of the system. Hence multilevel inverters are used in such applications. Multilevel inverters are classified into two major categories with single source and multiple sources. H-Bridge topology is used in multiple source inverters and the single source inverters use large capacitor banks. Fig. 1b shows the proposed MLI topology with Multi level Boost converter topology.

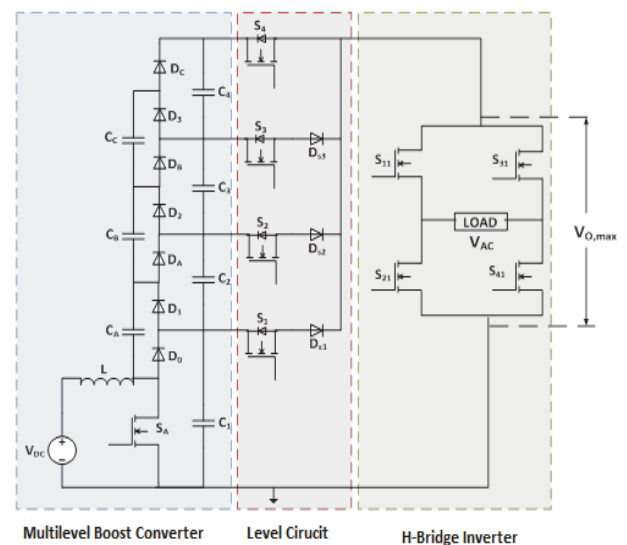

Figure 1b Proposed MLI topology with Multi boost DC to DC converter

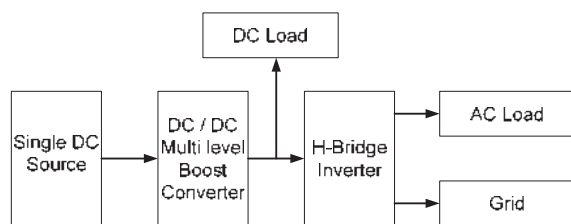

Figure 1a Proposed MLI block diagram

The AC power supply with high power quality and less THD is the primary requirement for the significance of High power. To meet this requirement multilevel inverters are normally used for their sinusoidal like output. In general, the renewable energy sources are DC. It is very

The minimum power renewable energy sources have no significance in high power applications, the dc boost converters are used to interface low power sources [20]. The proposed topology can be built for both low and high power application. This circuit consists of a single source multi-level boost converter whose output is the source of H-Bridge inverter. M-level inverter output can be obtained through this topology. The M-level stepped AC output voltage waveform can be obtained using one DC source, minimum number of switches, diodes and capacitors.

Applications of the extended MLI circuit are listed below: computer, telecom power supplies in remote areas supplied from solar panels, electric vehicles [22], uninterrupted power supplies [4] and renewable energy microgrid [21, 23].

# Design and Implementation of Multilevel Cascaded Boost converter fed Multilevel Inverter

Vijayalakshmi.S<sup>1</sup>, Marimuthu.M<sup>2</sup>, Paranthagan.B<sup>3</sup>, Dharneesh.K<sup>4</sup>, Manojkumar.P<sup>5</sup>, Kalaiarasan.G<sup>6</sup>, Surendran.R<sup>7</sup>

<sup>1</sup>Department of Electrical and Electronic Engineering, Saranathan College of Engineering, Trichy, Tamilnadu, India, Mail id: [bksviji@gmail.com](mailto:bksviji@gmail.com)

<sup>2</sup>Department of Electrical and Electronic Engineering, Saranathan College of Engineering, Trichy, Tamilnadu, India, Mail id: [marimuthueeephd@gmail.com](mailto:marimuthueeephd@gmail.com)

<sup>3</sup>Department of Electrical and Electronic Engineering, Saranathan College of Engineering, Trichy, Tamilnadu, India, Mail id: [paranthagan-eee@saranathan.ac.in](mailto:paranthagan-eee@saranathan.ac.in)

<sup>4</sup>Department of Electrical and Electronic Engineering, Saranathan College of Engineering, Trichy, Tamilnadu, India, Mail id: [dharneeshkalai@gmail.com](mailto:dharneeshkalai@gmail.com)

<sup>5</sup>Department of Electrical and Electronic Engineering, Saranathan College of Engineering, Trichy, Tamilnadu, India, Mail id: [manojkumar7622502@gmail.com](mailto:manojkumar7622502@gmail.com)

<sup>6</sup>Department of Electrical and Electronic Engineering, Saranathan College of Engineering, Trichy, Tamilnadu, India, Mail id: [kalaiaraangopal820@gmail.com](mailto:kalaiaraangopal820@gmail.com)

<sup>7</sup>Department of Electrical and Electronic Engineering, Saranathan College of Engineering, Trichy, Tamilnadu, India, Mail id: [surendran1819@gmail.com](mailto:surendran1819@gmail.com)

**Abstract**— Herein, a venture is contrived and executed with Multilevel Cascaded Boost converter fed Multilevel Inverter. This paper comes up with two grades, one specifies Multilevel Cascaded Boost Converter and other is Cascaded H-Bridge inverter. The Multilevel Cascaded Boost converter changes the single DC input into five stages and H-Bridge inverter converts DC output from converter into an AC. The output voltage stages of the converter can be enhanced by including capacitor and diode in the output terminal. This paper manages the machination and persistent state investigation of converter and inverter and the simulation have been performed exploiting MatLAB/Simulink.

**Keywords-** *Multilevel Converter; Cascaded Boost Converter; voltage multiplier cell; H-Bridge Inverter and Level Circuit.*

## I. INTRODUCTION

For the time being, the fossil fuels generate worry due to the fact that they are not persistent and will eventually shrink, became too expensive day by day and are environmentally damaging to reclaim. Besides the fossil fuels like coal, oil, natural gases are producing a risky effect and polluting the environment which are responsible for the climatic changes. Hence the renewable energy resources are becoming high attraction encompassed by the renewable energy resources. The photovoltaic power gaining the big league in future. Due to the captivating facts like pure, no charge of emission, and less maintenances. In many countries Photo Voltaic system are getting a rapid growth in domestic as well as in industrial applications. One big challenge is to afford an incorporation of DC low voltage PV module to utility grid. As a method to increase the available power a topology called Multilevel Converters are employed. This paper, a Novel topology called Multilevel Cascaded Boost Converter has been introduced to maximize the power obtained from the PV module.

# SINGLE PHASE MULTILEVEL INVERTER BASED ON A NOVEL SWITCHING SCHEME USING BUCK CONVERTER

Paranthagan.B<sup>1</sup>, Vijayalakshmi.S<sup>2</sup>, Marimuthu.M<sup>3</sup>, Vijay.R<sup>4</sup>, Satheesh.R<sup>5</sup>

<sup>1</sup>Department of Electrical and Electronics Engineering, Saranathan College of Engineering, Trichy, Tamilnadu, India, Mail id: [paranthagan-eee@saranathan.ac.in](mailto:paranthagan-eee@saranathan.ac.in)

<sup>2</sup>Department of Electrical and Electronics Engineering, Saranathan College of Engineering, Trichy, Tamilnadu, India, Mail id: [bksvijji@gmail.com](mailto:bksvijji@gmail.com)

<sup>3</sup>Department of Electrical and Electronics Engineering, Saranathan College of Engineering, Trichy, Tamilnadu, India, Mail id: [marimuthueeephd@gmail.com](mailto:marimuthueeephd@gmail.com)

<sup>4</sup>Department of Electrical and Electronics Engineering, Saranathan College of Engineering, Trichy, Tamilnadu, India, Mail id: [vijay-eee@saranathan.ac.in](mailto:vijay-eee@saranathan.ac.in)

<sup>5</sup>Department of Electrical and Electronics Engineering, Saranathan College of Engineering, Trichy, Tamilnadu, India, Mail id: [satheesh-eee@saranathan.ac.in](mailto:satheesh-eee@saranathan.ac.in)

**Abstract**— This paper presents a single phase multilevel inverter (MLI) based on a novel switching scheme. This new design produces a substantial decline in the count of power devices and capacitors required to implement a multilevel output battery-powered application. The proposed scheme has two stages namely, DC-DC converter and Inverter. Multilevel are achieved for the inverter by altering duty cycle of the DC-DC converter. In the MATLAB/SIMULINK setting, the proposed idea was implemented and the outcomes were validated.

**Keywords**- DC-DC Converter, Buck Converter, Multilevel Inverter, MATLAB

## I. INTRODUCTION

Due to the benefits of high power waveforms, less harmonic distortion, low common mode voltage, low switching operations, medium, high-voltage and high power capacity, multilevel inverters have become popular in recent years. Usually, an inverter is a system that uses certain electronic circuits to transform DC electrical power into AC type.

Buck converters can be highly efficient (often greater than 90%), making them helpful for tasks such as converting a computer's main (bulk) supply voltage (often 12 V) down to lower USB, DRAM and CPU voltages.. Buck converters are used in self-regulating power supplies and advanced telecom and data-com systems

Generally, a simple inverter provides 2 or 3 output voltage levels. But the multilevel inverter produces 5 levels of output voltage or more. As compared to a 2 stage inverter, it generates a stepped output voltage with reduced harmonic distortion. It offers higher levels of output voltage and power. The inverter requires a fixed dc voltage that can be extracted from the converter.

The multilevel inverter, correlated with lower output harmonics, provides high power capability. Their main downside is their complexity, which includes a large number of power devices and passive parts, as well as a very complex control circuit.



# JOURNAL OF REMOTE SENSING GIS & TECHNOLOGY

- HOME
- ABOUT
- LOGIN
- REGISTER
- CATEGORIES
- SEARCH
- CURRENT
- ARCHIVES
- ANNOUNCEMENTS

Home > Vol 6, No 3 (2020) > Vijayalakshmi

Open Access Subscription Access

## ISLAND MICRO-GRID HEALTH TRACKER SHOES

S. Vijayalakshmi, M. Marimuthu, S. K. Lakshmi, S. Megadharshini Megadharshini, K. Narmada Devi

### ABSTRACT

This paper presents an automated wearable technology that is being incorporated into an essential daily accessory, a shoe. This ensures round the clock monitoring of health and activity. Since being self-powered, accuracy and compatibility are the key features of the paper. Harvesting parasitic mechanical as well as thermal energy makes the shoe an island Pico grid that can function effectively.

### FULL TEXT:

PDF

### REFERENCES

Emaus A, Degerstrøm J, Wilsgaard T, Hansen

BH, Dieli- Conwright CM, Furberg AS, Pettersen SA, Andersen LB, Eggen AE, Bernstein L, Thune I. (2010), Does a variation in self-reported physical activity Reflect variation in objectively measured physical activity, resting heart rate, and physical fitness? Results from the Tromso study, Scand J Public Health, DOI: 10.1177/1403494810378919.

World Health Organization (2017), Global Strategy on Diet, Physical Activity, and Health, WHO, Available at: <http://www.who.int/dietphysicalactivity/pa/en> website.

Finkelstein EA, Haaland BA, Bilger M,Sahasranaman A, Sloan RA, Nang EE, Evenson K. R. (2016), Effectiveness of activity trackers with and without incentives to increase physical activity (TRIPPA): a randomized controlled trial, Lancet Diabetes Endocrinol, DOI: 10.1016/S2213-8587(16)30284-4.

Jakicic J M, Davis KK, Rogers RJ, King WC, Marcus MD, Helsel D, Rickman AD, Wahed AS, Belle SH (2016), Effect of wearable technology combined with lifestyle intervention on long-term weight loss: the IDEA randomized clinical trial, J Am Med Assoc, DOI: 10.1001/jama.2016.12858.

Susana Carneiro, Joana Silva, Bruno Aguiar, Tiago Rocha, Ines Sousa, Tiago Montanha and Jose Ribeiro (2015), “Accelerometer- Based Methods for Energy Expenditure using the Smartphone, 2015 IEEE International Symposium on Medical Measurements and Applications (MeMeA) Proceedings, DOI: 10.1109/MeMeA.2015.7145190.

Meethu Malu, Leah Findlater (2016), “Toward Accessible Health and Fitness Tracking for People with Mobility

### OPEN JOURNAL SYSTEMS

[Journal Help](#)

### USER

Username

Password

Remember me

### SUBSCRIPTION

[Login to verify subscription](#)

### NOTIFICATIONS

[View](#)  
[Subscribe](#)

### JOURNAL CONTENT

Search

Search Scope

### Browse

- [By Issue](#)
- [By Author](#)
- [By Title](#)
- [Other Journals](#)
- [Categories](#)

### FONT SIZE

### INFORMATION

- [For Readers](#)
- [For Authors](#)
- [For Librarians](#)

# Symmetric Multilevel Inverter Using DC-DC Zeta Converter

S.Srinithi  
Department of Electrical and  
Electronics Engineering  
Saranathan College of Engineering  
Trichy, India  
ssrinithiselvi@gmail.com

Dr.S.Vijayalakshmi  
Department of Electrical and  
Electronics Engineering  
Saranathan College of Engineering  
Trichy, India  
bksvijji@gmail.com

M.Marimuthu  
Department of Electrical and  
Electronics Engineering  
Saranathan College of Engineering  
Trichy, India  
marimuthueeephd@gmail.com

B.Parathagan  
Department of Electrical and  
Electronics Engineering  
Saranathan College of Engineering  
Trichy, India  
parathagan-eee@sarathan.ac.in

**Abstract**— This paper presented is an attempt to suggest a high-gain Zeta converter with a voltage multiplier cell is fed with multilevel H-Bridge inverter. A perfect mixture of a slightly modified version of the regular Zeta converter and a voltage multiplier unit is the proposed circuit. The voltage addition of the suggested refitted zeta enhances the voltage gain by increasing n time of the multiplier unit. The proposed converter decreases the voltage issue over the transition, which concludes the superior output and the gain is improved without disrupting the primary circuit. In inverter to use minimum switches and get M-level output. The thorough study of the proposed converter with numerical analysis is now achieved with the help of MatLAB/Simulink.

**Keywords**— Multilevel Zeta (MLZ), Voltage-Multiplier unit (VMU), H-Bridge inverter.

## I. INTRODUCTION

DC to DC converters are the circuits that transform direct current sources to another voltage level by adjusting the duty cycle of the main circuit switches. These converters are commonly used in power distribution systems, dc motor drive applications and switched mode dc power system. Now a day it can be used in the maximum power point tracking in PV panel like a buck-boost converter. The Zeta converter design is identical to the SEPIC converter. The advantages of Zeta converter over the SEPIC converter are: 1. It has stable feedback loop even if the voltage range is wide it can provide a very good output voltage with relation. 2. Low output ripple, the output ripple of the Zeta converter is also lower than an equivalent SEPIC converter design. The multilevel Zeta converter is the combination of both conventional Zeta and the Voltage Multiplier Unit (VMU). The number of levels is easily added by the number of capacitors and diodes.

The excellence output voltage waveform depends on the number of inverter voltage level sand the number of output voltage level rises, the waveform become more sinusoidal [6]. To fulfill this requirement multilevel inverters are commonly used for their sinusoidal output wave. It is very challenging to get pure sine wave AC output with the use of

filter and it is very expensive, this can be easily achieved through multilevel inverter's (MLI) used. In MLI's are 1. Single source inverter 2.Multi source inverters. In our suggested circuit consists of single DC source only. This topology can be designed for both high and low power application. In the suggested scheme consists of two stages: the first is a multi-level DC-DC Zeta converter, which gives the DC output voltage value with the help of the VMU, get the N number of output levels, and the second one is the level circuit combine with H-Bridge inverter circuit, get the M level inverter outputs. Its actual details are seen in Fig.1.The M level stepped alternating current (AC) output voltage is easily obtained by only one DC source, with low number of power electronic components.

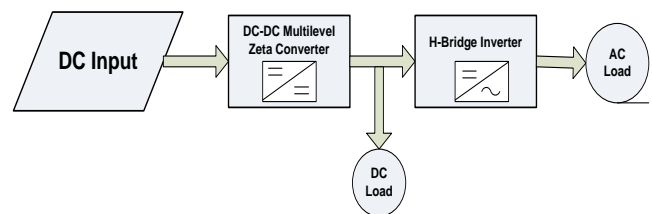

Fig. 1. Block diagram of proposed model

The main application of the MLI's are solar PV system, E-vehicles', auto mobiles, Fuel cells and Uninterrupted power supplies (UPS). Normal MLI's are complex structure need more input sources and stresses along the switches. In our suggested methodology simple in structure and used only one input source also reduced the switches stress. It is a symmetric MLI's DC source outputs are equal in magnitude.

## II. PROPOSED CONVERTER WITH INVERTER

The proposed model of DC-DC Zeta converter fed MLI's is illustrated in Fig. 2.

The Zeta converter is connected to the multiplier unit which is fed to the MLI via level switches. The DC-AC conversion is based on the Level circuit and the H-Bridge inverter.

# Analysis of PV Panel based Bidirectional Converter for Electric Vehicle

Vijayalakshmi S  
Department of EEE  
Saranathan college of Engineering,  
Trichy, India  
bksviji@gmail.com

Shivabalan N  
Department of EEE  
Saranathan college of Engineering,  
Trichy, India  
shivabalan1999@gmail.com

Thayananth.T  
Department of EEE  
Saranathan college of Engineering,  
Trichy, India

Marimuthu M  
Department of EEE  
Saranathan college of Engineering,  
Trichy, India  
marimuthueephd@gmail.com

Shathishkumar VK  
Department of EEE  
Saranathan college of Engineering  
Trichy, India  
shathishgokul@gmail.com

Venugopal. R  
Department of EEE  
Saranathan college of Engineering,  
Trichy, India  
venugopal-eee@saranathan.ac.in

Pravinraj T  
Department of EEE  
Saranathan college of Engineering  
Trichy, India  
pravinprince1122@gmail.com

**Abstract - This paper present an analysis of PV panel based Bidirectional converter for Electric vehicle charging. This system consists of solar cell battery, bidirectional dc -dc converter. A Battery is provided for supply power to dc motor during no sunlight condition. The bidirectional dc-dc converter is working in both charging and discharging the battery and can manage the flow of power in both the direction and hence excess energy from the PV panel can be stored in battery. MPPT controller extract maximum power from the PV module under the impact of varying irradiance and varying the load conditions. Model Performance evaluation and analysis has been done through MatLAB/Simulink**

**Keywords : PV panel, Bidirectional Converter, battery, Maximum Power Point Tracking (MPPT).**

## I. INTRODUCTION

Solar energy becomes the most challenging energy sources. In fact, a lot of domestic & industrial or commercial applications use solar energy. Solar energy is a key source to reduce Co2 emissions. On our country, ICE (Internal combustion Engines) are a major source of pollution, hence Electric vehicles become the promising solution. For many reasons taking into account, environmental and cost considerations, renewable energy sources such as solar energy is preferable to charge plug-in electric vehicles. In India, mostly IC engines where used for the transportation. In order to reduce environmental pollution and climatic change and increasing price of fossil fuels, Indian government encourages to promotes more and more electrical vehicles (EV). The Indian government set a target to accelerate the adoption of Electrical vehicles to reduce pollution and many other advantages like high torque and easy speed control. However, all IC engines have to be replaced by an energy storage battery with the help of suitable converter.

In [1] the authors propose an AC charging station with second life Li-ion battery, integrating solar PV, and wind energy. This station is grid connected which allows the export or import energy depending on the utilization. The authors in [2], [4] a control strategy of a multi-port, grid connected, direct DC PV charging station was proposed, the source of energy here can be either PV panels or AC grid, the transfer of energy from AC grid is bidirectional, hence, PV

energy can be injected on AC grid. These two topologies use many converters, which reduce efficiency. In [5] a charging strategy is proposed to minimize the energy cost, the charging time is divided into intervals to minimize the peak consumption of a fleet of EVs during day time. The charging station in this case is grid connected; in addition, the topology was not given.

The effect of fast charging EVs on the AC grid was investigated in [8]: the charging station in [8] is a DC fast charging, and only the grid is used as energy source. The energy source is not renewable and the efficiency is decreased by using two converters. Four possible architectures for a solar EV charger are proposed and compared in [9], these configurations are also grid connected, two possible choices for interconnection to the AC grid: AC inter-connection or DC inter-connection. The efficiency is decreased by the use of several DC-DC and DC-AC converters.

Our proposed PV fed bidirectional converter for EV vehicle is illustrated in Figure 1. This block diagram consists of PV panel, bidirectional converter, battery, and E-bike. The power from PV panel is irregular in nature, so when solar power generation is higher than the demand of the load, then the surplus energy is served to the battery station via bidirectional converter. Any time when the load demand goes beyond the instantaneous solar power generation, the shortfall of power demand is supplied by the station battery through the converter. When the absence of solar power, the battery power is transferred to the load through bidirectional converter. This study can be done for 1KW Solar charging station to charge electric bikes. P&O algorithm has been used in our system for implementing MPPT, due to its simplicity and less computational demands. Also, no prior knowledge of the PV system is necessary for the algorithm to work. The sun has been playing numerous roles in humane existence.

In this paper, section 2 consists of proposed circuit, section 3 contains simulation circuit and results discussion are carried out in section 4, finally section 5 consists of conclusion.

# A Novel Isolated DC-DC Multi-Level Flyback Converter for Multi-Level Inverter Application

Venugopal R

Department of Electrical and  
Electronics Engineering  
Saranathan College of Engineering  
Trichy, India  
venugopalramadoss@gmail.com

Dr. Vijayalakshimi S

Department of Electrical and  
Electronics Engineering  
Saranathan College of Engineering  
Trichy, India  
bksviji@gmail.com

Marimuthu M

Department of Electrical and  
Electronics Engineering  
Saranathan College of Engineering  
Trichy, India  
marimuthueephd@gmail.com

Chandra Kishore M

Department of Electrical and  
Electronics Engineering  
Saranathan College of Engineering  
Trichy, India  
chandra.083.ck@gmail.com

Mohammed Rifat Z

Department of Electrical and  
Electronics Engineering  
Saranathan College of Engineering  
Trichy, India  
rifatzahir@gmail.com

Niresh Shankar P

Department of Electrical and  
Electronics Engineering  
Saranathan College of Engineering  
Trichy, India  
niresshine@gmail.com

**Abstract --- The main theme of this paper is to present a high voltage gain dc-dc boost converter using flyback and multilevel concept. The proposed converter focuses on multilevel outputs with voltage multiplier cell. The input of the general dc-dc converters is either PV array or battery or fuel cell. The circuit is composed of diodes and capacitors which acts as voltage multiplier and also as a rectifier. The implemented multilevel flyback converter can be connected to an H-bridge forming a multilevel inverter. With the help of a single driven semiconductor switch namely MOSFET, the designed converter can produce a high voltage gain in continuous conduction mode. The proposed multilevel flyback converter has been simulated and verified with theoretical values. The results have been demonstrated in the report.**

**Keywords --- Flyback Converter - Multilevel Flyback - Voltage Multiplier (VM).**

## I. INTRODUCTION

Intergovernmental Panel on Climate Change, regularly access the latest climate science reports for every country which is established in 1988. The earth's average temperature is rising at an unprecedented rate, causing rapid warming and climate changes in the contrary of fossil fuels like coal and petrol. Since 1973, various acts like Air act which aims to control the levels of air pollution through measures of National Ambient Air Quality Standards (NAAQS) and Motor vehicles Act (1988) is aimed to address the vehicular traffic and transportation of hazardous wastes. In order to reduce consumption of fossil fuels, solar cars comes into picture. Hybrid Solar vehicles and Commercial Solar Vehicles are replacing the conventional auto Mobiles. The Solar Vehicles requires a wide range dc input voltages for its operation so the demand for DC-DC Converters are in the rise. Isolated converter which has high voltage is combined with VM cell is implemented in this paper.

The flyback converter is a power supply topology that uses mutually coupled inductor or transformer to store energy. The flyback converters are similar to the booster converters in architecture and performance. However, the primary winding of the transformer replaces inductor while

the secondary provides the output. In the flyback configuration, the primary and secondary windings of transformer are utilized as two separate inductors. The basic flyback converter uses a relatively small number of components. A switching device chops the input DC voltage and the energy in the primary is transferred to the secondary through the switching transformer. A diode in the secondary rectifies the voltage while the capacitor boosts and removes the ripple.

A voltage multiplier is an electrical circuit with combination of capacitor and diode that converts AC electrical power from a lower voltage to a higher DC voltage. Voltage multiplier cells are very much similar to rectifier. Usage in electrical and electronic application such as in microwave ovens, strong electric field coils for cathode-ray tubes, electrostatic and high voltage test equipment, etc. The DC output voltage of a rectifier is limited to the peak value of its sinusoidal input voltage. While combining multiple diodes and capacitors as VM cells, we can effectively multiply the DC output voltage for some odd or even multiples.

## II. DESIGN AND OPERATION OF MULTILEVEL FLYBACK CONVERTER

The overall block diagram for the need of high gain converter is shown in fig 1. The ultimatum of the proposed converter is to design a multilevel flyback converter using voltage multiplier cells. This interlinking of flyback and VM makes it possible to develop any number of levels of output just by adding combinations of diodes and capacitors. The main topology is to terminate the limitation of output.

The circuit is going to be operated in continuous conduction mode. Hence an inductor which act as a filter is connected parallel in the primary side of transformer. The inductor is used to limit high input voltage. A single semiconductor switch N-channel MOSFET has been used to control the pwm. Arduino micro controller has been used to provide gate pulse to the MOSFET. The switching frequency implemented is 50 kHz. The converter can operate in extremely high frequencies and so smaller value of inductor is enough. The circuit diagram has been shown in fig 2.

# Non-isolated Multilevel Zeta Converter for MLI Application

Proceedings of International Conference on Power Electronics and Renewable Energy Systems pp 21-30 | Cite as

- Marikannu Marimuthu (1)
- Subramanian Vijayalakshmi (1)
- B. Paranthagan (2)
- R. Venugopal (3)
- S. Srinithi (4)
- B. Yuvaraj (5)
- R. Soundarajan (5)
- S. K. Vasantha Kumar (5)

1. Department of Electrical and Electronics Engineering, Saranathan College of Engineering, , Trichy, India

2. Associate Professor, Department of Electrical and Electronics Engineering, Saranathan College of Engineering, , Trichy, India

3. Assistant Professor, Department of Electrical and Electronics Engineering, Saranathan College of Engineering, , Trichy, India

4. PG Scholar, Department of Electrical and Electronics Engineering, Saranathan College of Engineering, , Trichy, India

5. UG Student, Department of Electrical and Electronics Engineering, Saranathan College of Engineering, , Trichy, India

Conference paper

First Online: 22 November 2021

- 64 Downloads

Part of the [Lecture Notes in Electrical Engineering](#) book series (LNEE, volume 795)

## Abstract

A new multilevel zeta converter which converts fixed DC voltage to multilevel DC output voltage is discussed in this paper. Proposed converter has stable voltage feedback capacity and produces high gain output voltages with less input current. Voltage supplied by the PV panel or the fuel cell is at an output of a low voltage. These output voltages can be interfaced with standalone (or) grid connected inverter system by employing the proposed converter. By using a single transistor with the multilevel capacitor geometric structure, the proposed converter is able to generate an output voltage that is much higher and has ripple free output current with a higher step-up conversion ratio. It allows for operation at much higher frequencies for a much longer

# Modified Multi Input Multilevel DC-DC Boost Converter for Hybrid Energy Systems

Ram Prakash Ponraj, Devadharshini Ganeshprabhu, Haripriya Balaji, Hemadharshini Ganesan, Keerthana Dhanabalan

**Abstract:** DC-DC converters are playing an important role in designing of Electric Vehicles, integration of solar cells and other DC applications. Contemporary high power applications use multilevel converters that have multi stage outputs for integrating low voltage sources. Conventional DC-DC converters use single source and have complex structure while using for Hybrid Energy Systems. This paper proposes a multi-input, multi-output DC-DC converter to produce constant output voltage at different input voltage conditions. This topology is best suitable for hybrid power systems where the output voltage is variable due to environmental conditions. It reduces the requirement of magnetic components in the circuit and also reduces the switching losses. The proposed topology has two parts namely multi-input boost converter and level-balancing circuit. Boost converter increases the input voltage and Level Balancing Circuit produce Multi output. Equal values of capacitors are used in Level Balancing Circuit to ensure the constant output voltage at all output stages. The operating modes of each part are given and the design parameters of each part are calculated. Performance of the proposed topology is verified using MATLAB/Simulink simulation which shows the correctness of the analytical approach. Hardware is also presented to evaluate the simulation results.

**Keywords :** DC-DC converter, Multi input Multi output (MIMO), PWM technique, wide-input range, level-balancing, hybrid energy systems.

## I. INTRODUCTION

Availability of fossil fuels depleted and the price increases over the years. Increasing demand thrive the studies on alternate energy sources. Renewable energy sources are found to be the right alternate for the fossil fuels and available abundant in nature. New methodologies have been introduced over the past years to increase the stake of the renewable energy sources and also to meet the increasing power demand. Inverters and Converters were widely used however choppers had less attention in power conversion in

Revised Manuscript Received on April 12, 2020.

\* Correspondence Author

**Ram Prakash Ponraj\*** is currently working as Assistant Professor in Department of Electrical and Electronics Engineering in Saranathan College of Engineering, Tiruchirapalli, India. PH-+919487676423. E-mail: gprahara@gmail.com

**Devadharshini Ganeshprabhu** is currently pursuing her Bachelor degree in Electrical and Electronics Engineering in Saranathan College of Engineering, Tiruchirapalli, India.

**Haripriya Balaji** is currently pursuing her Bachelor degree in Electrical and Electronics Engineering in Saranathan College of Engineering, Tiruchirapalli, India.

**Hemadharshini Ganesan** is currently pursuing her Bachelor degree in Electrical and Electronics Engineering in Saranathan College of Engineering, Tiruchirapalli, India.

**Keerthana Dhanabalan** is currently pursuing her Bachelor degree in Electrical and Electronics Engineering in Saranathan College of Engineering, Tiruchirapalli, India.

spite of used virtually in all power conversion processes [1]. At the present time, due to Electric Vehicles and of various advantages like low harmonics and low EMI DC-dc converters are gathering attention and the use of DC-DC converters are burgeoning [2].

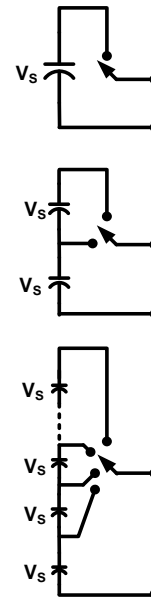

Fig.1. Basic DC-DC conversion system

Choppers also use less magnetic components that decrease the complexity of the circuit and overall manufacturing cost [3]. But the DC-DC converters have more voltage balancing problems compared to converters and inverters [4]. Most of the renewable energy sources are not being used throughout the year and their utilization is limited. By using multiple sources; normally renewable energy sources, hybrid power systems increase the reliability and utilization of renewable energy sources [5].

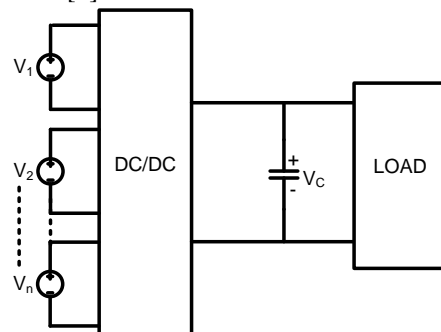

Fig.2. DC-DC converter system with multiple sources

# Modified Multi-Level Boost Inverter For Hybrid Energy Systems

Titus Sigamani, Ram Prakash Ponraj

**Abstract:** Applications of Renewable Energy Sources increased rapidly on the limited availability of fossil fuels and the environmental awareness over the decades. Hybrid System uses two or more input sources for the single output and this is normally used over the limited availability of renewable energy sources. Wind Energy and solar Energy are normally used as sources in hybrid energy system whereas fuel cells are also used in some limited applications. This paper proposes a multilevel Inverter system for hybrid energy sources with unequal voltage values. The proposed converter is explained with and without Boost operation. This paper also proposes a suitable PWM technique to control the voltage and frequency of the system and also to make the system ready for grid connection. The MATLAB/ Simulink simulation with the results are presented to validate the performance of proposed multilevel inverter system.

**Index Terms:** Boost Converter, Inverter, Pulse Width Modulation, Hybrid Systems, Photovoltaic, Wind Energy Conversion, Multi-level.

## 1. INTRODUCTION

THE invention of Multi-level inverters is the significant achievement in the modern power electronics, since they have numerous advantages over conventional inverters in the fields of Electrical Engineering. Diode Clamped MLI (DCMLI), Flying Capacitor MLI (FCMLI) and Cascaded H Bridge MLI (CHMLI) are the commonly used conventional multi-level inverters [1-2]. DCMLI and FCMLI use single source for power conversion while the CHMLI uses multiple number of sources which decides the number of output voltage levels and the requirement of filters [3-4]. The voltage sources used in the CHMLI have the same value or the multiple of fundamental value based on the application, complexity of the control circuit and the filter design considerations [5-6]. The modern MLI structures use reduced number of power electronic switches compared to the conventional structures [7-10]. To reduce the number of input sources, series connected capacitors are used as a potential dividers. To achieve balanced voltage across all DC-link capacitors, a separate feedback circuit is used [11-12] which increases the complexity of the circuit. In the case of renewable energy source input, the voltage is normally DC and variable in nature. The variable voltage has to be converted into constant voltage by controlling the pulse width of the chopper circuit used [13]. If more than one source is used, traditionally separate dc/dc converter was used for each source. The cost, complexity, switching losses etc., will be more in this method. In order to reduce this problem of separate chopper circuit, a double input dc/dc converter which can transmit power individually and simultaneously is proposed.

The energy provided from these systems is variable and dependent of the climatic conditions, this make that the energy that can be delivered to the load is also variable. Then the converters used in these applications must permit to demand power to both input voltage sources simultaneously or to each one independently, depending on the availability of the voltage sources [14]. This is made traditionally with two independent converters, with a common DC bus voltage, but these increase the cost of the system. Converters with two inputs have been used as shown in Fig. 1, which permits to demand current from both inputs. Complex controller and circuits are considered in the schemes reported in literature. In this paper is presented a different converter capable to accept two low input voltages, and the power can be demanded from both converters simultaneously or independently depending on the availability of the voltage source. The operation of the converter is simple and just one controller is used [15]. The output of the boost converter is given to a self-balancing circuit use capacitors to maintain the constant voltage which is given to the level shifter circuit. The H-Bridge circuit in the system used to convert the unidirectional current into the bidirectional current [16]. The output voltage is an AC voltage derived from the hybrid voltage sources with unequal values [17].

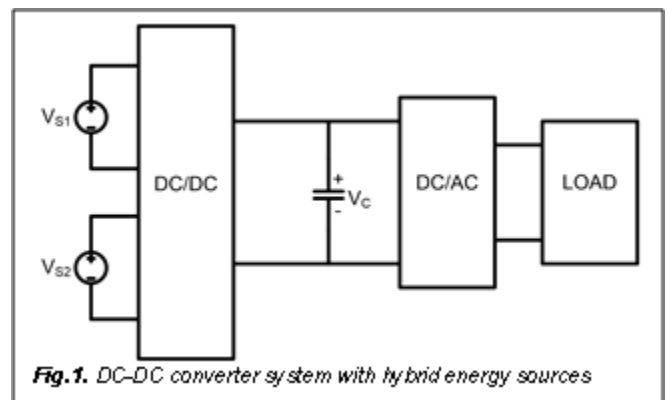

Fig.1. DC-DC converter system with hybrid energy sources

- Titus Sigamani is currently working as Professor in Department of Electrical and Electronics Engineering in K.Ramakrishnan College of Engineering, Tiruchirapalli, India. PH-+919443690147. E-mail: drs.titus@gmail.com
- Ram Prakash Ponraj is currently working as Assistant Professor in Department of Electrical and Electronics Engineering in Saranathan College of Engineering, Tiruchirapalli, India. PH-+919487676423. E-mail: gprsahara@gmail.com

# Modified Single Phase Matrix Converter with Z-Source for Renewable Energy Systems

Titus Sigamani

Department of Electrical and Electronics Engineering  
 K.Ramakrishnan College of Engineering,  
 Tamil Nadu, India  
 drs.titus@gmail.com

Ram Prakash Ponraj

Department of Electrical and Electronics Engineering  
 Saranathan College of Engineering  
 Tamil Nadu, India

Vijay Ravindran

Department of Electrical and Electronics Engineering  
 Saranathan College of Engineering  
 Tamil Nadu, India

**Abstract**— This article terms the use of a buck-boost z-source conversion approach for renewable energy applications with a modified matrix converter topology (MMCT). This system removes the intermediate DC link and offers direct conversion. The z-source matrix converter (MC) is used to switch the basic frequency and lower the magnetic additive essentials. Within the system provided, the FPGA controller is used to manipulate the excessive-pace control loops for gate pulse generation rather than for the PWM controller. The power converter's total harmonic distortion (THD) is minimized by the use of appropriate filters and techniques that improve the output power quality. As an alternative to the AC-DC-AC converter method, this article addresses the significance of an AC-AC matrix converter as an interface power converter between the variable load and the wind energy network. The new system is related to a conventional system and observed that the proposed topology for the converter that provides better output power in the conversion system for wind energy. MATLAB/Simulink was used to simulate the proposed device, and the tests were checked and analyzed with hardware setup.

**Keywords**— Z-source, matrix converter, PWM, buck-boost, modified converter

## I. INTRODUCTION

The continuous and high quality power supply is the major need for industrial and home applications. A system is required to tap the power not only from the grid but also from other sources of non-conventional energy. The matrix converter converts AC to AC directly instead of existing AC to DC to AC [1]. Matrix converters (MC) are capable of power regeneration and deletion of input current harmonics [2]. But, a matrix converter can also be used as any converter like rectifier, inverter, AC voltage regulator, etc., by changing its switching sequence. These characteristics of the matrix converter are used to develop a hybrid system with multiple inputs and a single output. Normally, the multilevel inverters and DC-DC converters are used for the hybrid system integration and lowering the THD in various applications [3-8]. The output of the matrix converter was synchronized with the grid without any intermediate arrangement. [9, 10]. The main advantage of the matrix converter is to get variable frequency output from an input source with constant frequency. The line-side and load-side converters do not have an energy storage feature [11, 18]. Use of various PWM

methods narrates the functions of matrix converter in various levels and the main aim is to generate sinusoidal current on the sides of input and output [12]. PWM control in Self-commutation switches improve the performance of AC voltage regulators [16]. Present solutions to the numerous technological problems and challenges facing the deployment of valid matrix converters are presented along with current industrial applications [13]. So, a powerful control algorithm is required if we are using DC or AC drives [14, 15]. All the major studies mainly focus on three phase direct and indirect topologies [17-19]. To avoid the intermediate DC link and to get a nearly sinusoidal output, a new matrix converter topology is proposed. The system block diagram is given in Figure 1.

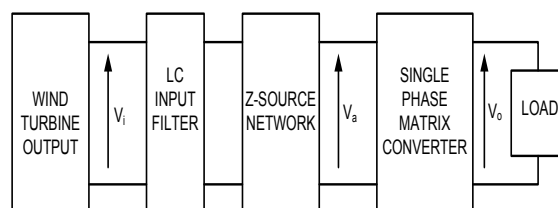

Figure.1 Block diagram of suggested system

## II. PROPOSED TOPOLOGY

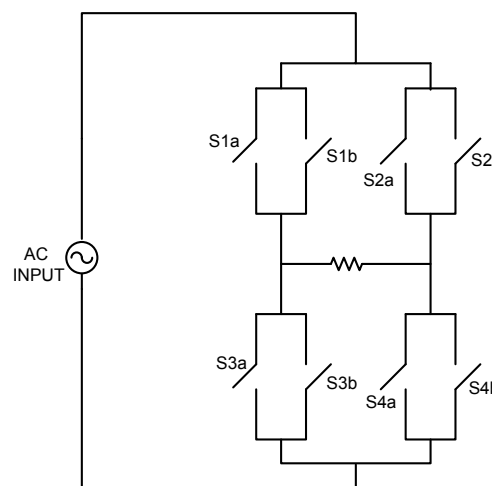

Figure. 2 One Phase MC Circuit



*A novel design and performance  
improvement of symmetric multilevel  
inverter with reduced switches using genetic  
algorithm*

**Ram Prakash Ponraj & Titus Sigamani**

**Soft Computing**

A Fusion of Foundations,  
Methodologies and Applications

ISSN 1432-7643

Volume 25

Number 6

Soft Comput (2021) 25:4597-4607

DOI 10.1007/s00500-020-05466-7



# A Developed H-Bridge Cascaded Multilevel Inverter with Reduced Switch Count

Ram Prakash Ponraj<sup>1</sup> · Titus Sigamani<sup>2</sup> · Vijayalakshmi Subramanian<sup>1</sup>

Received: 7 October 2020 / Revised: 14 December 2020 / Accepted: 28 January 2021 / Published online: 18 February 2021  
© The Korean Institute of Electrical Engineers 2021

## Abstract

Multilevel Inverter integrates several Direct Current (DC) sources to produce a single-phase Alternating Current (AC) waveform that can be used to meet the domestic and commercial power demand. This article introduces a novel Multi Source Cascaded Multilevel Inverter with a reduced number of switches for the efficient use of DC voltage sources. The conversion efficiency can be increased by the presented topology which is simple in design to overcome the significant switching losses in the power electronics devices. Optimal Firing Angle and Phase Opposition Disposition Pulse width Modulation Techniques were used to reduce the harmonics at the desired output of the inverter and also to improve the power quality of the presented topology. This article also proposes two Asymmetric Multilevel Inverter Topologies. A comparison has been made, on the number of switches required and the efficiency of the inverters to differentiate the presented Topologies from other topologies of the multilevel inverter. Finally, the performance characteristics of the presented topologies have been designed and investigated using MATLAB Simulation. Simulation results were validated using an experimental setup.

**Keywords** Modified multilevel inverter · Pulse width modulation (PWM) · Total harmonic distortion (THD) · Optimal firing angle control (OFA) · Power quality

## 1 Introduction

The energy demand is rising day by day due to the advancement of the industrial sector. To preserve fossil fuels for the future, the scope of energy generation relies heavily on renewable energy sources. The installation of a PV plant in the industry serves non-critical loads, thus reducing tariff stress in the industry [1]. The power extracted from PV is DC that must be converted to AC for further use by integrating it with an inverter. The design of the conventional H-bridge inverter for medium and high load ratings makes the system size larger and more expensive. The Level of THD is also high while combining solar PV with a conventional H-bridge inverter. Multilevel inverters (MLIs) were introduced with different topologies [2] to improve the quality of inverter power. Generally, classified MLI topologies

are voltage source inverters (VSI) and current source inverters (CSI) [3]. Some of the notable VSI classified designs are Neutral Point Clamped (NPC), Flying capacitors (FC), and Cascaded H-Bridge (CHB) inverters [4]. The nature of robustness, reliability, and efficiency in the synthesis of quality output signals makes CHB an appropriate tool for integrating it into the Renewable Energy conversion systems [5]. The CHB can be modeled either in symmetric or asymmetric operating mode. CHB is said to operate in symmetric mode when it has similar DC source as input and produce linear output voltage upon input source voltage. In asymmetric mode, CHB has dissimilar input DC voltage sources and produces either linear or non-linear output depending on the input voltage source [6, 7]. The modified CHB topology is developed to address the problem of non-balancing voltage [8] to reduce the number of switches requirement. An MLI system [9] was designed to operate under symmetrical and asymmetrical operating modes for high voltage applications. MLI structures with the modified H-Bridge Topology were proposed [10, 11] and these topologies use a high number of switching devices. This entire setup is used as a basic unit to generate AC output signals from the DC source. The main objectives of Multilevel Inverters are reducing the number of

✉ Ram Prakash Ponraj  
gprsahara@gmail.com

<sup>1</sup> Department of Electrical and Electronics Engineering,  
Saranathan College of Engineering, Trichy, India

<sup>2</sup> Department of Electrical and Electronics Engineering,  
K.Ramakrishnan College of Engineering, Trichy, India

Search results - ramprakash.ees@sta... My Drive - Google Drive Journal Publications - Google Sheets Dynamic Performance Enhancem... x +

ieeexplore.ieee.org/abstract/document/9456403

## Dynamic Performance Enhancement of Modified Sepic Converter

Publisher: IEEE Cite This PDF

Vijay Ravindran ; RamPrakash Ponraj ; S Syed ZameerBasha ; N Santhosh Kanna ; S SamuelRaj ; B Sabarish All Authors

2 Paper Citations 28 Full Text Views

Abstract

**Abstract:**  
This paper introduced a non-isolated DC-DC boost converter with high voltage gain and low switching voltage stress for any level of input and output voltage applications. The high boost converter is designed with the concept of Single Ended Primary Inductor Converter called as modified SEPIC converter. Normal Boost and SEPIC converters were assessed and compared to the updated SEPIC converter for their efficiency. For the modified converter, a 15 V input voltage and a 170 V output voltage with 100 W output power are suitable. Moreover, for switching the converter uses lower input current and displays low voltage stress. In general, the high-gain SEPIC DC-DC converters would have a high ripple value, which would make the output voltage unstable. But in our modified SEPIC converter, the output voltage and current are steady DC values without any ripples. The study of time reaction indicates that the suggested converter settles faster than the other comparable converter at steady state voltage and current.

**Published in:** 2021 2nd International Conference for Emerging Technology (INCET)

Document Sections

- I. Introduction
- II. Related Works
- III. Boost Converter and Sepic
- IV. Modified Sepic Converter
- V. Working Principle:

Show Full Outline

More Like This

Discussions on control loop design in average current mode control [PWM DC/DC power converters]  
Conference Record of the 2000 IEEE Industry Applications Conference, Thirty-Fifth IAS Annual Meeting and World Conference on Industrial Applications of Electrical Energy (Cat. No.00CH37129)  
Published: 2000

Saturable reactor assisted soft-switching full-bridge DC-DC power converters  
IEE Proceedings B - Electric Power Applications  
Published: 1991

Show More

16:17 25-01-2022

Search results - ramprakash.ees@sta... My Drive - Google Drive Journal Publications - Google Sheets Simulated Design and Impl... x Dynamic Performance Enhancem... +

ieeexplore.ieee.org/abstract/document/9456131

## Simulated Design and Implementation of Solar based Water Pumping System

Publisher: IEEE Cite This PDF

Vijay Ravindran ; RamPrakash Ponraj ; R PRAVEEN ; K Praveenkumar ; P Ravichandran ; T Sivaramakrishnan All Authors

1 Paper Citation 72 Full Text Views

Abstract

**Abstract:**  
The efficiency of solar PV systems is influenced by external factors such as solar irradiance and temperature. Because of the low cost and environmentally friendly design, Photovoltaic (PV) based water pumping systems are viable alternative to conventional water pumps which are powered by electricity or diesel. Hence these systems are perfect for those areas that do not have connections to the power grid. As a consequence, in this article; we will look at how solar energy is transformed into electrical energy using a boost converter. The boost converter is used when the output voltage from a solar panel is inadequate to power a motor. A MATLAB/Simulink-based designs of a solar-powered pumping system with a DC Motor were performed in this study.

**Published in:** 2021 2nd International Conference for Emerging Technology (INCET)

**Date of Conference:** 21-23 May 2021 **INSPEC Accession Number:** 20712796

Document Sections

- I. Introduction
- II. Related Works
- III. Operation Involved In Solar Photo Voltaic Cells
- IV. Design and Operation of Boost Converter:
- V. Calculation of Duty Cycle:

More Like This

Grid interfaced solar PV based water pumping using brushless DC motor drive  
2016 IEEE International Conference on Power Electronics, Drives and Energy Systems (PEDES)  
Published: 2016

Solar Photovoltaic based Brushless DC Motor Driven Water Pumping System using PSO-MPPT Algorithm  
2019 54th International Universities Power Engineering Conference (IUPERC)  
Published: 2019

Show More

16:17 25-01-2022

## Design and Implementation of Proportional Resonant Controller for Power Inverters

C.Pearline Kamalini<sup>1</sup>, Dr.M.V.Suganyadevi<sup>2</sup>, Bharathi Freetha K<sup>3</sup>,  
Madhu shree S<sup>4</sup>

<sup>1</sup> AssistatProfessor, [pearline-eee@saranathan.ac.in](mailto:pearline-eee@saranathan.ac.in)

<sup>2</sup> Associate Professor, [suganyadevi-eee@saranathan.ac.in](mailto:suganyadevi-eee@saranathan.ac.in)

<sup>3,4</sup> UG students, [ms.s.madhushree@gmail.com](mailto:ms.s.madhushree@gmail.com)

Department of EEE, Saranathan College of Engineering, Trichy

### ABSTRACT.

This paper provides a design procedure of single-phase inverter with LC filter and the inverter load current is regulated by Proportional-resonant controller. The Proportional-resonant controller provides an effective control of single-phase inverter suitable for various Distributed Generation systems i.e grid connected and stand-alone systems. The performance study is based on frequency response and the model is simulated in MATLAB/SIMULINK environment which provides better stability, improved load current regulation with low THD value prescribed in the IEEE standards. The prototype model is also fabricated with Atmega328 processor and performance are satisfied.

**Keywords:** PV inverter, LC filter, PR controller, APF,THD.

Date of Submission: 10-07-2021

Date of Acceptance: 26-07-2021

### I. INTRODUCTION

Inverter is one of the main power conditioning devices in the integration of renewable energy, other distributed energy sources. Voltage source converter is the basic component in power quality improvement to filter out the harmonics i.e Active Power filters and Facts devices. The power conversion from DC to AC with good power quality is from an Inverter. As a consequence, power converters for renewable energy sources are becoming increasingly common. It's vital to produce clean and green energy. It is important to sustain the inverter output and the proposed system is designed with an LC filter to filter out high frequency components. [1] The various control techniques to control the PV inverters to provide high quality of output current and voltage connected to a linear or

non-linear load are hysteresis current controller, Predictive Current controller, Proportional Integral (PI) controller and Proportional Resonant (PR) controller [2]. The effect of harmonics such as power losses, decay of quality power reduces the equipment life and failure of components. In a grid-connected application, for example, the power converter must follow many typical grid parameters, including voltage, current, frequency, harmonics, power factor, and flicker.

Based on literature the hysteresis controller is simple, unconditional stability and good accuracy with comprehensive band harmonic spectrum. The predictive controller force the measured current to track the reference current. The famous conventional controller PI controller produces steady state error while tracking the sinusoidal reference due to dynamic integral term[3]. The proposed PR controller provides zero steady state error, high gain in wide range of frequency response with fast tracking of specified references and with low value of %THD. The block diagram of single-phase inverter with PR controller is shown in Fig:1.

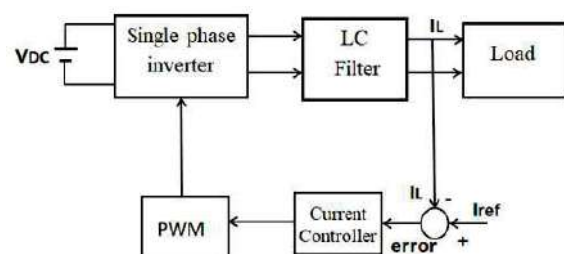

Fig.1 Closed loop Block diagram of single-phase inverter

## A Proposed Fuzzy Logic Based THD For Sinusoidal And Nonsinusoidal Situations

A.R.Danila Shirly<sup>1</sup>, C.Pearline Kamalini<sup>2</sup>

<sup>1,2</sup> Assistant Professor Department of EEE, Saranathan College of Engineering, Trichy, India.

**Abstract** - Assessing the electric force quality (EPQ) turns out to be vital errand because of the broad utilization of nonlinear burdens. In a liberated climate, having distinctive force quality lists (PQIs) with various qualities has no significance except if they are consolidated into single worth that could address them. In this paper, another fuzzy force quality file (FPQI) is presented that amalgamates the suggested PQIs, for example, all out request mutilation, absolute consonant contortion, uprooting power factor, transmission proficiency power factor and swaying power factor. The proposed FPQI was applied to nonlinear burden with various contortion cases under sinusoidal and nonsinusoidal circumstances. It is shown that the new FPQI is expressive and precisely addresses the current force quality records in all cases and in all circumstances. Contemplating the benefits of the fuzzy frameworks like straightforwardness, simplicity of utilization, adaptability, speed and capacity to manage imprecision and vulnerabilities, this record can be valuable for power quality assessment, financially savvy investigation of PQ alleviation procedures, just as charging purposes

**Keywords**: Fuzzy logic system, harmonics, power factor, power quality, total demand distortion (TDD), total harmonic distortion (THD).

### I. INTRODUCTION

IN the most recent decade, the force conveyance framework has been exposed to significant changes because of coordinating more sustainable power sources with the electric lattice alongside nonlinear burdens. More up to date age load hardware, with chip based controls and force electronic gadgets, is more delicate to voltage and current waveform contortions than gear utilized previously. As an outcome, the requirement for assessing the electric force quality has emerged with the end goal of precisely measuring the force quality unsettling influence. In conveyance frameworks, the current symphonies mutilation ought to be restricted to a worthy cut off to abstain from warming, misfortunes and breaking down of influence framework parts. The absolute interest bending (TDD) was presented in IEEE Std. 519-1992 [1] to quantify the current twisting level rather than the complete symphonies bending (THD) that was presented in the previous adaptation of the IEEE Std. 519-1981 [2]. TDD, which is suggested in the IEEE Standard 519-1992, is a record that evaluates the music twisting level in the current waveform. TDD esteems alone are adequately not to absolutely depict the symphonies bending level. For specific circumstances in the force framework, TDD esteems ought to be identified with hamper level (the proportion of the short out current to the greatest interest load current).

Utilization of fuzzy rationale for taking care of force framework issue can be found in [3-8]. The fuzzy rationale approach enjoys numerous benefits, for example, being straightforward, simple to apply, adaptable and ready to deal with loose or questionable issues. The improvement of a fuzzy master framework for power quality applications was proposed in [9]. In [10], another fuzzy complete interest bending factor (FTDDF) is proposed. The FTDDF shows the degree of bending in the current waveform and furthermore permits choosing whether the contortion contained in the current is inside as far as possible or not. In [11], another versatile neuro-fuzzy deduction framework based all out request bending factor (ANFIS TDDF) is proposed, that communicates how much the current waveform is liberated from twisting. A fuzzy controlled adaptable framework for sounds, unbalance and voltage droop pay was proposed in [12]. Measuring electric force quality by means of fuzzy demonstrating and logical order handling is examined in [13]. Fuzzy examinations on power quality record and assessment was done in [14].

## Modified Bridgeless Buck Rectifier for Led Applications

C. Pearline Kamalini<sup>1</sup>, M. V. Suganya Devi<sup>2</sup>

<sup>1</sup>Assistant Professor, <sup>2</sup>Associate Professor, Department of Electronics and Electrical Engineering, Saranathan College of Engineering, Thiruchirapalli, Tamil Nadu, India

\*Corresponding Author: pearline-eee@saranathan.ac.in

### ABSTRACT

A great bridgeless buck rectifier for power factor control with a single inductor is planned which extensively builds the proficiency by decreasing the quantity of directing semiconductor segments. The low usage of the attractive segment in the customary bridgeless buck rectifier builds execution. The proposed rectifier's proficiency is additionally improved by disposing of information connect diodes. Likewise, the rectifier duplicates its yield voltage which broadens utilize capable energy of the mass capacitor after an exit the line voltage. The reenactment of open circle controlled bridgeless buck PFC rectifier with a single inductor and altered converter is acted in MATLAB programming thus its activity is confirmed. The prototype circuit is designed to produce a 12V output voltage suitable for LED applications.

**Keywords**--Bridgeless Converters, Buck Converter, Magnetic Utilization, Power Factor correction, Rectifier

### INTRODUCTION

Presently a-days ac-dc power supplies are utilized in numerous electrical and gadgets applications like battery charges, personal computers, and so forth These force supplies should satisfy certain global guidelines to have required proficiency at various force levels. However, power supplies associated with ac mains present symphonious flows inside the utility. It is very notable that these consonant flows cause a few issues like voltage mutilation, warming, clamor, and

lessen the fitness of line to deliver energy.

Electrical planners are persistently looking for occasions to expand PF, decrease THD check, improve proficiency in this force supplies. Consequently, Bridgeless force factor rectification circuits are one among the answers for satisfying these necessities [1].

A scaffold diode rectifier followed by an ordinary lift converter has is the most normally utilized PFC circuit as a result of its straightforwardness and great PF execution [2]. Nonetheless, a lift PFC front end shows 1 – 3 % lesser effectiveness at 100V line contrasted with that at 230V line. This drop of proficiency at low line can be ascribed to expanded information current and produce higher misfortunes in semiconductors. Thus to diminish this misfortune bridgeless lift geography which disposes of the utilization of extension rectifier was presented [3]. The bridgeless lift PFC has similar disadvantages to regular lift converter, for example, high voltage stress, high normal mode commotion, no inrush current insurance, and low attractive usage. These disadvantages of lift PFC converter can be overwhelmed by actualizing buck PFC geography.

This paper analyses the operation of a Modified bridgeless buck rectifier with a single inductor [4] and the block diagram is shown in Fig.1. Generally, a bridgeless buck rectifier has its output voltage twice that of a conventional buck rectifier, it is designed in such a way that it needs harmonic limit specifications. Moreover switching losses of the dc-dc output stage of bridgeless buck rectifier is effectively lower than that of boost PFC circuit [5].

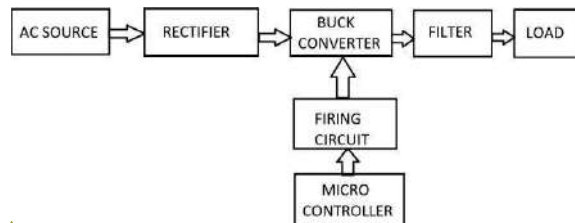

Figure 1: Block diagram of bridgeless buck rectifier for PFC.

# Power Quality Improvement using Series Active Power Filter

C Pearline Kamalini <sup>1</sup>Abinaya.T, Eazhilarasi.J, Hemadevi.T

<sup>1</sup>Assistant

Professor Department of EEE  
Saranathan College of Engineering

**Abstract**— Power quality issues are the major considerations in this modern power system due to the increased usage of power electronic based equipments. This paper describes how to reduce the harmonic distortion and thereby achieving power quality improvement by series active power filter. Harmonic currents in distribution system are increased by larger use of nonlinear loads. A series active power filter is the combination of shunt active power filter with transformer injection with a help of PI controller. Here a MATLAB SIMULINK software is used to simulate and expected results were obtained.

Keywords: Harmonics, THD, Power quality improvement (PQI), Series active power filter (SAPF).

## I. INTRODUCTION

Power quality is one of the major issues, in the modern electrical distribution system. The power quality can be analyzed as voltage unbalance, voltage sag and voltage swell, partial or total loss of one or more phases. The voltage unbalance is mainly caused due to uneven distribution of single-phase loads.

The lack of power quality leads to loss of production, damage of equipment or appliances, increased power losses, interference of communication lines and so on. The poor quality of voltage are also affected by the power system equipment and customer equipment's such as overhead and underground cables, transformers and rotating electric machines, protection systems. Traditionally, passive filters have been used for mitigating the distortion due to harmonic current in industrial power sector. But they have many drawbacks such as resonance problem, dependency of their performance on the system impedance, absorption of harmonic current of nonlinear loads, which could lead to further harmonic propagation through the power system.

Active power filters is introduced, to overcome such problem. It has no drawbacks when compared to passive filters. APF inject harmonic voltage or current with appropriate magnitudes and phase angle into the system and cancel harmonics of nonlinear loads.

But it also has some drawbacks such as high initial cost and high power losses due to which their wider applications are limited, especially with high power rating system. The more usage of power electronics based equipments has produced a predominant impact on quality of electric power supply.

Due to the increase in harmonic pollutions in the power system, it has attracted the attention of power electronics and power system engineers to develop dynamic and adjustable solutions to the power quality problems. The unbalanced voltage can be compensated with use of series active filter which regulate the voltage to the desired level.

In this paper, simulation of a single phase series active power filter is used for mitigating harmonics.

## II. FILTERS

A filter are circuits which performs signal processing functions, specifically to remove unwanted frequency components from the signal, to enhance wanted ones. Basically two types of filters are used for power quality problems such as Active Power filters and Passive Power filters

### 1. Passive filter:

The passive filters are used to reduce power quality problems. Moreover, apart from reducing the current harmonics, the passive filters also provide reactive power compensation, thereby, further gaining the system performance. Passive implementations of linear filters are based on combinations of resistors (R), inductors (L) and capacitors (C). These types are collectively known as passive filters, because they do not depend upon an external power supply and they do not contain active components such as transistors.

The most common type of passive filter used is the single tuned passive filter. A single tuned filter, which is a series RLC circuit tuned to a single harmonics frequency provides a low harmonic impedance. Another type of configuration is double tuned filter.

# FUZZY LOGIC CONTROLLER USING SHUNT ACTIVE POWER FILTER FOR POWER QUALITY IMPROVEMENT

C.Pearline Kamalini<sup>1</sup>, S.Divya<sup>2</sup>, V.Karthika<sup>2</sup>, P.Kiruthika<sup>2</sup>

<sup>1</sup> Assistant Professor Department of EEE

<sup>2</sup> UG Schloar Department of EEE

Saranathan College of Engineering

Trichy

## ABSTRACT:

This paper represents the study and simulation of fuzzy logic controller using matlab Simulink. The shunt active power filter is used for harmonics and reactive power compensation of non-linear loads. Here, dc capacitor is controlled by using fuzzy control algorithm. In order to produce high power quality by reducing source current total harmonic distortion. By varying the switching frequency, the performance of active filter is determined.

**KEYWORDS-** shunt active power filter (APF), power quality (PQ), fuzzy logic controller, harmonics, total harmonic distortion (THD).

## I. INTRODUCTION:

It comprises of voltage profile, frequency profile, harmonics contain and reliability of power supply.

Power quality refers to the ability of electrical equipment to consume the energy being supplied to it. A number of power quality issues including electrical harmonics, poor power factor, voltage instability and imbalance impact on the efficiency of electrical equipment. This has a number of consequences including:

- Higher energy usage and costs
- Higher maintenance costs
- Equipment instability and failure

Energy management is an important consideration for any business, and it is critical that power quality be assessed as part of any energy management strategy.[1]

The **quality** of electrical **power** is an **important** contributing factor to the development of any country and this can be achieved through continuous **power quality** monitoring which helps detect, record and prevent **power quality** problems.

**Power quality problems** are: Automatic Resets, Data Errors, Equipment Failure, Circuit Board Failure, Memory Loss, **Power Supply Problems**, UPS Alarms, Software Corruption, and Overheating of electrical distribution systems. This problems due the voltage sag, voltage swell and harmonics only.

In this project we removing the power quality problem HARMONICS, for improving the quality of power. The Power Quality (PQ) problem can be

Detected from one of the following several symptoms depending on the type of issue involved.

- Lamp flicker
- Frequent blackouts
- Sensitive-equipment frequent dropouts
- Voltage to ground in unexpected

- Locations
- Communications interference
- Overheated elements and equipment.

PE are the most important cause of harmonics, interharmonics, notches, and neutral currents. Harmonics are produced by rectifiers, ASDs, soft starters, electronic ballast for discharge lamps, switched-mode power supplies, and HVAC using ASDs [2]

## II. FILTERS:

It is a device which processing the function and it specially removes the unwanted signal frequency components.it consists of two types.

1. **Passive filter**
2. **Active filter**

### PASSIVE FILTERS:

It is a device (or) processing the function and it is made up of passive components such as resistors, capacitors, and inductor. [3]

### ACTIVE FILTERS:

It employs RC network and amplifiers with feedback and it is having more number of advantages, in order to perform elimination of both higher and lower order of harmonics, filter out the harmonics in which significantly below the filter switching frequency.

## III. Shunt active power filter:

Shunt Active power filters is the device which generate the same amount of harmonic generated by the load in which **180 degree** phase shifted. So these harmonics are inserted into the line at the point of common coupling the load current harmonics are eliminated and the utility supply becomes sinusoidal. There are basically two types of active filter: **Series active powerfilter andshunt active power filter.**

We using shunt active power filter for removing the harmonic problem improving the power quality in three phase transmission line where non-linear loads are connected.

Active power filter:

1. Dominate the harmonics problems
2. It is used as both higher and lower order of harmonic in the power system.

### CONDITIONS:

1. When current gets decreased, harmonic is produced.
2. When current gets decreased, voltage fluctuation and distortion are produced.[4]



## LOW COST POWER QUALITY ANALYSER WITH DATA LOGGING

Ramprasath.S<sup>1</sup>, Booma.G<sup>2</sup>, Dharshini.R<sup>3</sup>, Joicy.J<sup>4</sup>, Nandhini.T<sup>5</sup>

Assistant professor<sup>1</sup>, UG student <sup>2,3,4,5</sup>, Saranathan college of Engineering, Trichy-12.

[ramprasath-eee@saranathan.ac.in](mailto:ramprasath-eee@saranathan.ac.in), [booma249@gmail.com](mailto:booma249@gmail.com), [dharshiniraj26@gmail.com](mailto:dharshiniraj26@gmail.com), [joicyjohnson1998@gmail.com](mailto:joicyjohnson1998@gmail.com),  
[rosynandhini1999@gmail.com](mailto:rosynandhini1999@gmail.com)

**ABSTRACT-** In this prototype, an automated smart remote metering system, low cost power quality analyser (LCPQA) is fabricated to measure true root mean square value of voltage, current and Power factor for small scale industries. The measurement system is an ARDUINO UNO based master-slave wireless technology that incorporates smart monitoring via Android mobile application. This wireless technology requires ESP8266 wifi module for transmitting and receiving data. The hardware model of the smart metering system senses voltage and current by graphical method to find true RMS values and calculates parameters like power, power factor and energy. Remotexy open source android application act as a front end for remote monitoring and it helps to generate embedded code for data manipulation. As of now the data can be monitored within the wifi range. Further development is to collect data all over the world using cloud technology.

Key words – LCPQA, Remotexy, ESP8266.

### I. INTRODUCTION

In the power grid of the future, sensors and transducers will play an important role to monitor energy in real time. The analyzer can provide remote power monitoring and data storage capability, so as to take decisions in real time. This proposed LCPQ analyzer is provided with data logging facility and [1], [2] remote monitoring of the electrical parameters.

The term smart digital device implies a time-sampled system. An analog-to-digital converter (ADC) samples current and voltage from transducers' output at a high frequency. The digital processor translates real-world waveforms to binary words which can be manipulated by software to measure electrical parameters. The ADC's resolution and speed influence the duplication quality of continuous time signals, also affects the microprocessor bandwidth required for calculations. Analog value once converted to a digital signal, the voltage and current waveforms can be manipulated by software code to extract any necessary information for smart electrical systems. The main function of controllers is to collect data samples at regular intervals and the sample time determines the operating speed of the LVPQA.

Noise sensitive equipment and machine that needs stable flow of energy have become a standard. Because of that, power quality concern has increased and the consumers are looking for the best option in the market of electrical energy. Any power problem manifested in voltage, current or frequency deviations result in failure of customer equipment. The power quality meter available in market is capable of measuring all power quality parameters such as phase currents, voltages, real, reactive and apparent power, power factor etc. The cost of that power quality analyzer is very high. So we framed our goal to develop cost effective and better efficiency device. A smart wireless monitoring system [3] for measuring voltage, current and power is designed and implemented. It monitors single phase electrical parameters using an Arduino microcontroller

to read the true RMS voltage and true RMS current from sensors and then send the measured data to mobile applications using ESP8266 wifi module. The smart monitoring system Arduino UNO [5] basic board is interfaced with ESP8266 wifi module to collect and monitor data within the wifi range. The voltage sensing is done using LEM LV25-p Hall voltage sensor which has inherent galvanic separation between the primary circuit and secondary circuit which is capable of measuring up to 500V AC. Current is sensed using ACS712 Hall Effect-Based Linear Current Sensor with 2.1 KV RMS Voltage Isolation. Remotexy [6] android mobile application software is used to interface smart phone with Arduino controller using wifi to monitor the electrical parameters. The complete block diagram of smart wireless monitoring system is shown in figure 1.1.

# PWM RECTIFIERS: STATE OF ART FOR ACTIVE POWER FACTOR CORRECTION

S. SIVASUBRAMANIAN SURENDRAN.K. R M. PAVINTHAN A. AJITH KUMAR  
[sssmanian97@gmail.com](mailto:sssmanian97@gmail.com) [surendranram98@gmail.com](mailto:surendranram98@gmail.com) [pavinthanpapu07@gmail.com](mailto:pavinthanpapu07@gmail.com) [thalaasa1999@gmail.com](mailto:thalaasa1999@gmail.com)

S. RAMPRASATH

[ramprasath-eee@saranathan.ac.in](mailto:ramprasath-eee@saranathan.ac.in)

ELECTRICAL AND ELECTRONICS DEPARTMENT  
 SARANATHAN COLLEGE OF ENGINEERING

**Abstract**— Rectifiers are almost inevitable in all electronic circuits. This paper contains simulation and implementation of a single-phase PWM boost rectifier operating at a unity power factor. The power circuit used is a single-phase full bridge converter made of MOSFET switches. The algorithm used for control provides the regulation of the output DC voltage as well as the control of supply current harmonics. The experimental framework offers several advantages such as: simplified control system, sinusoidal ac line current that satisfies the harmonic current standard IEC 1000-3-2 Class D [2].

**Keywords**—PWM AC-DC convertors, C2000 based PWM switching, Active power factor correction, Regulated DC voltage.

## I. INTRODUCTION

Conventional rectifiers used diode bridge rectifier circuits which has the following demerits,

- i) They produce a lagging displacement factor with respect to the distributed system voltage.
- ii) Increased total harmonic distortion (THD) of ac supply current.

These aspects have a dismissive influence on both power factor and power quality. So, they were replaced with thyristor-controlled rectifiers having good rectification efficiency while it created high level of current harmonics in input current. Harmonic current limits are recommended by the IEC standards (IEC 1000-3-2). The IEC 1000-3-2 International Standard [1] establishes limits to all low power single-phase equipment having an input current with a ‘special wave shape’ and an active input power  $P \leq 600W$ . Diode rectifier fails to comply with the standard, because the input current is highly distorted, and has a very low power factor due to its large harmonic content. In order to meet these requirements, power-factor correction techniques are essential. Additionally, it is desirable to have minimal size, high efficiency, and low electromagnetic interference Hence, we move on to Pulse width modulated rectifiers made of 4 MOSFET switches triggered by pulse width modulation pulses from C2000 microcontroller. By use of pulse width modulated rectifiers active power factor correction can be

implemented and also nearly sinusoidal input current waveform can be achieved.

## II. POWER FACTOR CORRECTION

### A. NEED FOR POWER FACTOR CORRECTION

Poor power factor signifies insufficient use of power and increase in the operating cost hence leading to poor performance. By use of power factor correction techniques input current waveform can be shaped into a perfect sinusoidal waveform. This in turn reduces the eddy current loss ( $I^2R$  losses), maximizes the real power, saves power bill and decreases the voltage drop.

### B. ACTIVE POWER FACTOR CORRECTION

The active power factor correction is used for nonlinear loads. In this technique switching pre regulator is placed in the input side. This pre regulator maintains the dc voltage and checks whether input current is in phase with supply voltage. Hence power factor can be corrected to near unity. This method of power factor correction is of high efficiency with values of power factor varying from 0.9 to 0.95. The conventional method which uses passive filters for power factor correction only results in power factor range of 0.7 to 0.75.

## III. PULSE WIDTH MODULATION RECTIFIERS

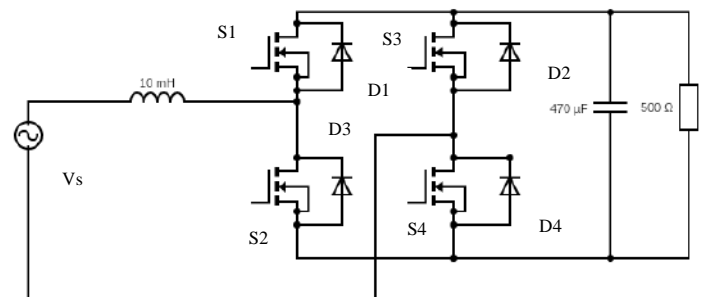

Figure 1: Single phase PWM boost rectifier using MOSFET

Pulse width Modulation (PWM) rectifier is an AC to DC power converter, that is implemented using forced commutated power electronic semiconductor switches. This paper uses MOSFET switches because of its higher

# **A Multi-Input DC-DC Converter with Effective Charging of Energy Storage Source**

**Mr.ABDUL RAHUMAN.S<sup>[1]</sup>, Mr.S.RAMPRASATH, M.Tech<sup>[2]</sup>**

*PG scholar, Dept. of EEE, Department of Electrical Engineering, Saranathan college of Engineering, Trichi, India.*

*Assistant Professor, Dept. of EEE, Saranathan college of Engineering, Trichi, India.*

**Email id : rahuman282@gmail.com**

## **ABSTRACT**

Renewable energy Is defined as that energy is collected from resources. That resources are sun, wind, sea, etc.,. Renewable energy often provides energy in four important area are electricity generation, heating , cooling, transportation, and rural energy services. In this proposed work is design a multi input dc boost converter using neutral network controller. The converter has the capability of providing the demand provide by load in options of one are more resources. And the

input sources are PV module, battery and fuel cell. These three sources are connected in series, which is fed to a boost converter with load. And the converter switches are controlled by neutral network controller. Using of neutral network controller we achieve a high efficiency, less switching stress and also some parameters. The operating condition of decides the working modes of the converter i.e. buck, boost and buck-boost mode. This approach is has to types of controlling such as open and close loop controlling. This implementation done in matlap

# Design and Simulation of Boost Converter with Extended Cell for Photovoltaic Application

R. Johnshi Rani, N. Vijayasarithi and S Ramprasath

**Abstract**--DC-DC converters are critical building blocks in energy harvesting systems which are applied to provide the energy for the solar cell applications. They are required to meet very strict specifications and consume as less power as possible. Regular small scale photovoltaic (PV) cells do not provide enough high voltage. As a result, a high voltage gain converter is essential. By using traditional boost converters, we cannot achieve the required high voltage gain, even with an extreme duty cycle. Therefore, a DC-DC boost converter is proposed in this paper for achieving high voltage gain by coupling inductors and the voltage lift technique. In this research a DC-DC boost converter with voltage extension cell is introduced to reduce losses and voltage stresses on circuit components. From theoretical analysis it has been analyzed that DC-DC boost converter coupled with extension cell enhances its voltage gain, which improve the life time of circuit components. Further to validate the proposed method, simulation has been performed in MATLAB Simulink Software to compare the output voltage of boost converter with and without proposed method, result shows that the output voltage of proposed method is 32V as compare to simple boost converter 25 V. Voltage stress in case of basic boost converter is 25V while for boost converter with extension cell is 10 V.

**Index Terms**--Photovoltaic cells, DC-DC boost converter, CCM boost converter, DCM boost converter, HVDC application

## I. INTRODUCTION

THIS eventual depletion of fossil fuels, combined with their negative effects on the environment has led to a recent developing shift in the adopted energy sources on a global scale to more sustainable and renewable sources that are also considered environmentally friendly. Among these are the Wind Turbines, Fuel Cells and Photovoltaics (PV), with the latter being an attractive choice to the parts of the world subjected to relatively higher solar irradiance levels. Nonetheless, integration of the high-power PV farms to the existing AC network grid, or HVDC systems requires the use of power electronics devices and technologies [1]. The PV output voltage is constrained to low DC voltage levels, typically with an open circuit voltage that is limited to 1500V per string for safety considerations. In other words, connecting the modules in series to directly obtain very high-voltage levels is not permissible due to safety concerns. Thus, such relatively small output voltage requires boosting to a much higher DC level in order to provide the appropriate DC Link for HVDC

system's connection or DC-AC conversion. However, many factors have to be taken into account while designing each power conditioning stage. As for the non-isolated type, several existing DC-DC converter types inherently have the capability of voltage boosting. Though, it is usually desired to utilize a converter that provides continuous input current since PV source current should be continuous for reduced capacitor sizing and proper maximum energy extraction. Solar Photovoltaic (PV) is a key technology option to realize the shift to a decarbonised energy supply and is projected to emerge as an attractive alternative electricity source in the future. Globally, the solar PV grid connected capacity has increased from 9.4 GW in 2007 to 15.7 GW in 2008 and was 67.4 GW at the end of 2012 [2,3]. Nowadays it is necessary to reduce the costs and increase the efficiency to make solar energy to be more useful. As a result, many research works address the development of solar power system in recent years with improved performances. Power electronics is a green technology, converting electrical energy from one form to another, achieving high conversion efficiency of the solar PV-powered system. The efficiency of solar PV powered-system depends mainly on the efficiency of the Maximum Power Point Tracking (MPPT) circuits [4].

## II. PHOTOVOLTAIC ENERGY SYSTEM

The output of solar PV cell is a Direct Current (DC), where the current is determined by the area of the cell and amount of exposed solar irradiation. The voltage of the individual silicon cell is in the order of 0.5V. Thereby, the cell has to be connected in a series to constitute modules with reasonable voltage level. The maximum power is delivered at the operating point, where the magnitudes of PV system and load resistance are equal. This is usually performed by an interfacing DC-DC power converter employing certain MPPT technique and algorithm. The operating point is held at MPP by regulating either the current or voltage of the MPPT converter. PV systems are usually used in three main fields: 1. Satellite applications, where the solar arrays provide power to satellites, 2. Off-grid applications, where solar arrays are used to power remote loads that are not connected to the electric grid, and 3. On-grid, or grid connected applications, in which solar arrays are used to supply energy to local loads as well as to the electric grid [5,6]. Typically, boost

R. Johnshi Rani, PG Student, Dept. of Electrical and Electronics Engineering, Saranathan Engineering College, Trichy, TN, India (e-mail: jaak3012@gmail.com).

N. Vijayasarithi, Asst. Professor, Electrical and Electronics Engineering, Saranathan Engineering College, Trichy, TN, India  
S Ramprasath Asst Professor Electrical and Electronics Engineering, Saranathan Engineering College, Trichy, TN, India

# Wireless Battery Monitoring System with Live Tracking for an Electric Vehicle

<sup>1</sup>\*S.Ramprasath, <sup>2</sup>Dr.C.Krishnakumar, <sup>3</sup>P.Rameshbabu

<sup>1,2</sup>Electrical and Electronics Engineering,  
<sup>1, 2, 3</sup> Saranathan college of Engineering, Trichy, India

**Abstract:** This paper presents a system to govern the battery parameters like voltage, charging/discharging current, temperature and location which helps in tracking the vehicle. In the developing technological sectors, electric vehicle is taking up its fast approach to its peak in the market and it's important to protect the system from fault and alerting the system. The major cost investment for an electric Vehicle is their Li-Ion batteries costs about half the total investment for the vehicle. Hence it's necessary to propose a Wireless battery management system (WBMS) which monitor the battery performance and for protection which increases longevity of the battery present in the electric vehicle. In our project we propose a control monitoring system which sense the live parameters and monitors remotely using ESP8266 Wi-Fi module interfaced with Arduino Uno Board. We use Blynk app to interface with different sensors. The completed model is place in our electric vehicle built to Participate in NSVU event help in Nagpur and won second overall prize.

**Keywords:** Battery, Li-ion, Blynk app

## 1. Introduction

In focus towards e-vehicle the major sector to be concentrated is battery. To examine the battery and its related parameters a flexible and compact system is build. Battery plays a major role in the operation of the e-vehicle, it is essential to govern the battery parameters and expand the life time of a battery. The quest to increase the span of an e-vehicle can be solved by governing the battery parameters related to voltage and current [1]. To process the same we need an interfacing medium which transmits the information to our smartphone. Blynk is the interfacing app which facilitates the interfacing between the system and smartphone. This app must be installed in our mobile phone to get the voltage and current parameters with the live location of our vehicle. In battery monitoring system we are about to implement a system that monitors the discharging voltage of the battery, current of the battery and live tracking of our car. Thus the life span of the electric vehicle can be protected from the undesired problems. Sensors are used to sense the parameters like current and voltage. Live tracking is also implemented to get the live location of our car. GPS module is used for tracking [2]. By doing this the life span of the battery can be increased with an added advantage of guiding the people with good platform. Cell balancing, Malfunction indication, status indication can be maintained.

In Electric Vehicles (EVs) the cells are connected in series-parallel combination to build high voltage and large capacity battery packs [3]. Factors causing cell voltage variation includes manufacturing methods, maintenance procedure and aging. In drive mode, these cells undergo electric and thermal ill-treatment due to the unpredictable load variations. In order to meet safety standards and to increase the battery life, a battery monitoring system (BMS) [4], [5] which properly monitors and controls each cell at every instant is mandatory. The WBMS was designed to minimize the Functionality of the slave module to only perform simple commands and send cell operating parameters. The master module is responsible for interpreting all of the data and deciding upon the actions the slave module should be taking [6], [7]. Figure 1 shows the overall block diagram of proposed WBMS. The proposed WBMS consists of a) Sensing module, b) Power supply module, c) Wireless Bluetooth module.

# Performance Analysis of Slope-Compensated Current Controlled Universal PV Battery Charger for Electric Vehicle Applications

Proceedings of International Conference on Power Electronics and Renewable Energy Systems pp 407-415 | Cite as

- S. Ramprasath (1) Email author (ramprasath-eee@saranathan.ac.in)
- R. Abarna (1)
- G. Anjuka (1)
- K. Deva Priya (1)
- S. Iswarya (1)
- C. Krishnakumar (1)

1. Saranathan College of Engineering, , Trichy, India

Conference paper

First Online: 22 November 2021

- 74 Downloads

Part of the [Lecture Notes in Electrical Engineering](#) book series (LNEE, volume 795)

## Abstract

The main purpose of the proposed system is to design a low-cost universal PV battery charger for electric vehicle application. The proposed system is integrated with a slope-compensated current controller which controls the charging current that corresponds to maximum power point of the PV module. As an interface converter, the proposed system consists of a buck converter to control the flow of the charging current and to find out the reference current  $I_{ref}$  from the PV array at MPP. The battery control circuit is implemented by measuring the state of charge (SOC) of the battery, and an LCD display has been used to monitor the battery parameters. This proposed system acts as a smart and efficient PV battery charger for e-vehicles.

## Keywords

Electric vehicle Battery charger State of charge Slope compensated

This is a preview of subscription content, [log in](#) to check access.

## References

# Simulation and Steady State Analysis of SIMO Boost Converter for Electric Vehicles

**Publisher:** IEEE

[Cite This](#)

[PDF](#)

C. Keerthika ; S. Ramprasath ; P. Rameshbabu ; C. Krishnakumar [All Authors](#)

76

Full

Text Views



## Abstract

### Document Sections

I. Introduction

II. Simo Converter Topology

III. Steady State Analysis

IV. Simulation Results

V. Conclusion

Authors

Figures

References

Keywords

Metrics

## Abstract:

Extreme environmental and human life issues such as global warming, air pollution and the rapid loss of oil resources in the planet are caused by the vast number of cars used. To overcome these issues traditional vehicles have been replaced by the Electric vehicles (EVs). To communicate the elements in the E-Vehicle DC-DC converters are used, by increasing or decreasing the input voltage levels. In order to efficiently reduce the quantity of electronic components to get different output voltages, Single-input Multiple-output DC-DC converters have been developed, also reduces cost. The SingleInput Multi-Output(SIMO) dc-dc converter delivers various levels of output voltage required by the load from a single source of dc input voltage. There are many SIMO topologies were evolved. In order to achieve the above limitations, in this project our work is to model a Single-Input Multiple-Outputs Boost converter. The suggested converter would uplift the voltage to a controllable middle voltage and high voltage dc output from a low voltage input power source. To validate the proposed topology for real time applications, the proposed converter is simulated in the MATLAB application.

**Published in:** 2021 2nd International Conference for Emerging Technology (INCET)

**Date of Conference:** 21-23 May 2021

**INSPEC Accession Number:** 20867097

**Date Added to IEEE Xplore:** 22 June 2021

**DOI:** 10.1109/INCET51464.2021.9456358

► **ISBN Information:**

**Publisher:** IEEE

**Conference Location:** Belagavi, India

# H<sub>2</sub>O FORECASTING

**Boopathinavaneethan.S** <sup>[s]</sup>, **Barath.R** <sup>[s]</sup>, **Bharanidharan M.S** <sup>[s]</sup>, **Lakshmi Narayanan.T** <sup>[s]</sup>, **Rameshbabu.P** <sup>[prof]</sup>. Department of Electrical & Electronics Engineering, Saranathan College of Engineering, Tiruchirappalli, Tamil Nadu, India

## Abstract

It is a real time implementation of water and its resources management system. For better understanding we can take a metro city. More over a metropolitan city is supplied with the fresh water by the Ministry of water resources in India. On having the power system department as a model we can also separate the water resources and distribution departments. The first department will be the resources department which includes lakes, rivers, underground bore wells etc. The second one is the department for purifying the water by some modern treatments such as chlorinating, UV treating etc. The third one will be the distributing one which distributes the water to each and every area in that specified metropolitan city. Now, the sensor which senses the flow and pressure of the water pipe will be fitted to each and every pipe of the above mentioned departments. These sensors will sense the data from the pipes and feeds it into a microcontroller. This microcontroller will feed the data to the clouds. Using the cloud computing system these data will be retrieved and they will be converted in to the graphs. These graphs will show the amount of the water flow in every area and we can monitor it by 24/7.

## Introduction

Water, the primary resource for all existing beings in history, war has been erupted for many reason like land ,minerals, oil, wealth and some more. But in recent times the war for the water and water resources has been triggered by some nations. Since the mankind evolved, we have been learning, acquiring, controlling and managing things. We all are doing these things to keep everything in an orderly manner. Once the orderly manner gets unbalanced, that place evidences a war. Water is not an unlimited quantity; it has become a limited edition thing. Since we have only 3% of fresh water we have to manage the resources in an orderly manner to supply the growing population of the world, which has already crossed 650billion.The above said orderly things will play a major role in managing the world's highly populated country India. It

consists of 12 million people. The major hotspots are the capital of each state of the country. Still the country is in its developing era, the states are mainly focusing on their metro-city, the capital of their state. To manage the water resources and to have an effective control and prediction of the water needs of their capital and other cities, this project will play a role as a game changer. Bangalore, the capital of Karnataka state was announced to be the second city running out of its water resources. There have been many disputes in sharing the water resources. For example the river Sindh's dispute between India and Pakistan, the river Brahmaputra's dispute between India and china and even with Bangladesh, the river Cauvery's dispute between the states Karnataka and Tamil Nadu. These disputes were not only due to the insufficiency of water and its resources but also due to the wastage and improper monitoring of the



# DESIGN AND IMPLEMENTATION OF IMPROVED INPUT QUALITY CURRENT CONTROLLED BUCK LED DRIVER

K.S.Anisha Farhin<sup>1</sup>, P.Ramesh Babu<sup>2</sup>

PG scholar,EEE,Saranathan College of Engineering,Trichy,India<sup>1</sup>

Assistant professor,EEE,Saranathan College of Engineering,Trichy,India<sup>2</sup>

**Abstract**— An active high input power factor corrected buck driver is carried out for LED lamp. Power Factor is an important performance parameter of a system. And improving power factor is very much essential for the better and economical performance of the system. The paper presents a detailed analysis of Buck converter with LC input filter operating in discontinuous capacitor voltage mode has inherent power factor correction properties and continuous input current providing as a input for 48V/100W LED lamp.

**Keywords**— DC – DC converter, power factor harmonics, DCVM, rectifiers .

## I. INTRODUCTION

The basic purpose of power factor correction circuit is used to make the line current follow the waveform of the line voltage so that the input to the power supply becomes purely resistive and hence to improve the power factor. The equipments generally used in industry, commercial and residential applications need to undergo rectification for their proper functioning and operation. . They are connected to the AC electrical utility comprising of non-linear loads and thus have non-linear input characteristics, which results in production of non-sinusoidal line current in AC utility. Also, current comprising of frequency components at multiples of line frequency is observed which lead to line harmonics. Hence there is a need to reduce the line current harmonics so as to improve the power factor of the system as per IEEE standards. The objective is to improve the power factor nearly unity with minimum Total Harmonic Distortion (THD) allowed into the utility i.e. A.C side.

The widely used structure of a power supply consists of a rectifier bridge, a dc–dc converter used to shape the input

current to sinusoidal form and a second dc–dc converter for output voltage regulation. The power factor correction (PFC) stage has inherent PFC properties, meaning that, at constant duty cycle and constant switching period, the input impedance of the PFC stage is essentially resistive and constant. Thus, the average input current of a converter with inherent PFC follows the shape of the input voltage, without the need for active control of the switch. Discontinuous inductor current mode (DICM) and discontinuous capacitor voltage mode (DCVM) are operating modes in which inherent PFC properties are obtained.

# DESIGN OF INPUT QUALITY CURRENT RECTIFIER BASED ON LUO TOPOLOGY IN MATLAB/SIMULINK ENVIRONMENT

Mr.P.RameshBabu <sup>1</sup>, Dr.C.Krishnakumar <sup>2</sup>, S.Kiruthiga <sup>3</sup>

Assistant Professor <sup>1</sup>, Professor & Head <sup>2</sup>, PG Scholar <sup>3</sup>

Department of Electrical and Electronics Engineering, Saranathan College of Engineering, Trichy, India

**Abstract**— This paper presents a new control scheme that deals with an active input power factor correction with single phase bridge rectifier fed LUO Converter Topology using Hysteresis current control Technique to compensate the harmonic current generated by the Diode Rectifier so as to achieve a power factor nearer to unity and to regulate the DC bus voltage. The comparison of an inductor current and ramp carrier waveform gives the Duty cycle which is associated with Hysteresis Controller in each switching period. The Hysteresis current controller is used to track the line current command. Benefits of this proposed Converter are high power density, Simple control strategy, less harmonic control content, nearly unity power factor and unidirectional power flow. As a result, the input current waveform is sinusoidal and in-phase with supply voltage having high power factor.

**Keywords**— Hysteresis current control, Voltage Gain, Power factor.

## I. INTRODUCTION

In our Day-to-day life, there is much importance to DC-DC Converter for satisfying domestic, Business, Agricultural and industrial needs. The utilization of DC-DC converters are increased because of the vast applications in various fields. In Transmission and Distribution networks, a serious power problem is created due to non-linear loads. For boosting the voltage in DC-DC converter circuit, Voltage-lift and Super-lift Technique are used. These techniques have been employed in DC-DC converters and used to Design high voltage gain converters. Voltage lift Technique increases the output voltage in Arithmetic progression, whereas the super-lift technique increases output voltage in Geometric progression. This technique enhances the voltage transfer gain effectively. The low power factor and high pulsating current from the AC mains are the main disadvantages of Diode rectifier in LUO topology which results in line voltage distortion, heating of core Transformer and Electrical Machines, increasing losses in transmission and distribution system.

In order to meet the required qualities of the current harmonics, the power factor correction is used to eliminate the harmonic current generated by the Diode Rectifier. The passive power factor correction method can reduce the harmonics up to some limit, but it cannot overcome the non-

characteristic Harmonics. This can be overcome by using active power factor correction method.



# Design and Simulation of MPPT Control for Solar Powered AC Autonomous LED Lighting Applications in MATLAB/Simulink Environment

P. Ramesh Babu, C. Krishnakumar, S. Kiruthiga

**Abstract:** As an AC LED light applications have become a commonplace item of light industry, it has a wide range of usage in garden lighting, cove lighting, office lighting and retail applications. The paper brings out the utilization of Boost converter along with Maximum Power Point Tracker (MPPT) technique for the control of Photovoltaic power. This proposed system which includes Boost converter, a single phase full bridge inverter with Sinusoidal Pulse Width Modulation (SPWM) technique. The main concept of this converter includes designing of boost converter that provides an output voltage of 350V DC and single phase SPWM provides 350V, pure sine wave output (230V RMS) applicable to AC autonomous LED Lighting system. In order to bring out a transformer free inverter, the designed boost converter is simulated in the MATLAB Simulink software and the results are shown with low THD as per IEEE standard, with acceptable power factor and higher efficiency.

**Keywords:** MPPT; Perturb and Observe Algorithm; Boost converter; Inverter, SPWM.

## I. INTRODUCTION

Industrial and Domestic energy production widely depends on a limited resource. Energy usage is playing an important role in day today's life. As electricity can be generated by burning the fossil fuels which leads to major drawback of severe/drastring climatic changes such as acid rain, global warming etc.,

In order to overcome these drawbacks, solar energy is widely used as the major source of energy for the generation of electrical energy from the photovoltaic array [5].

The step up or step down transformer used for the conversion of voltage in traditional inverters faces major drawbacks of its large size, higher total harmonic distortion and being high-priced.

These disadvantages are eliminated in this paper by introducing a single stage step up converter, to form a compact, inexpensive transformer free inverter. Maximum power point tracking (MPPT) mechanism is used for the extraction of maximum possible power using the Perturb and Observe algorithm from the PV array, which is considered as the most popular conventional method for capturing the required maximum power. This proposed system brings out a transformer less inverter which supports the benefits of having reduced size, compact, less priced and with low Total Harmonic Distortion (THD). Sinusoidal Pulse Width Modulation (SPWM) is generated by comparing the reference signal along with the triangular carrier wave and used for gating purpose in an inverter [12]. Finally, the proposed system is designed mathematically and simulated in MATLAB/Simulink software to verify the performance of various subsystems.

## II. BLOCK REPRESENTATION OF PROPOSED MPPT SYSTEM

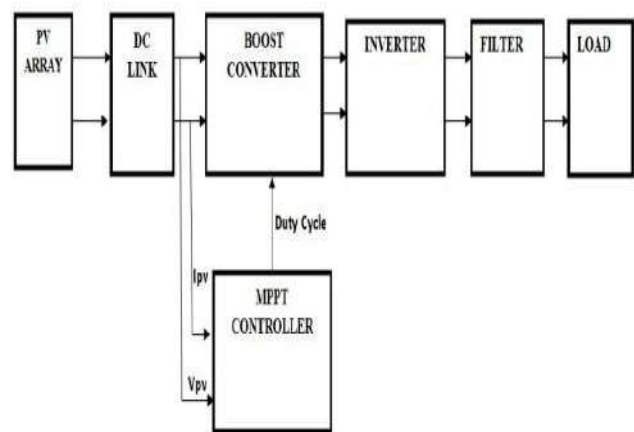

**Fig.1. Block representation of MPPT configuration**  
PV cells or arrays are the power source of the system, which are modeled by an equivalent circuit and simulated to show the exact behavior of a PV array. Then, the two power converters are used for the control of,  
1) Extracting maximum power  
2) Deliver of power to AC grid with an acceptable THD and Power Factor.

Revised Manuscript Received on March 17, 2020.

\* Correspondence Author

**P.Ramesh Babu\***, Assistant Professor in the department of EEE in Saranathan College of Engineering, Trichy.

**Dr.C.Krishnakumar**, Professor/Head in the department of EEE in Saranathan College of Engineering, Trichy.

**S.Kiruthiga**, PG Scholar in the department of Power Electronics and Drives in Saranathan College of Engineering, Trichy.

© The Authors. Published by Blue Eyes Intelligence Engineering and Sciences Publication (BEIESP). This is an open access article under the CC BY-NC-ND license (<http://creativecommons.org/licenses/by-nc-nd/4.0/>)

# Design and Implementation of Cloud based Digital Energy Meter using ESP8266

P. Ramesh Babu, A. Pradeep, P. Rajendra Prasath, R. Rishikesh kumar, J. Sharvin

**Abstract:** Increasing cost in energy sector demands for structured use of energy. It is vital to understand the rate of energy consumption during specific period utilizing Energy Meters. Energy consumption can be measured using a traditional energy meter; however, their use is restricted in inaccessible areas or in occasion of poor visibility resulting in limited functionality. Also, the main drawback is that a person has to take readings area by area from every house and institute make it time consuming. We propose a Cloud based Wireless Energy Meter [1] which can send data via wireless communication (cloud computing) to a PC or mobile phones in the form of E-mails or mobile application notification or through web page; where surveillance and analysis of the data will be made. This computational system can be used to measure energy quantities of transformers and high voltage towers at remote locations, industries, domestic area, and institutions.

**Keywords:** Arduino, Current sensor, Energy meter, IOT, Node MCU, Voltage sensor.

## I. INTRODUCTION

In recent days tracking of the electricity usage in traditional Energy meter is impossible and also analysis of data on the periodic basis is also complex. The consumer is facing severe problem like receiving the pay bill which is already paid, sometimes paying extra charges due to error while taking energy reading [2] and it is impossible to measure in inaccessible area. To overcome this problem and also to keep tracking, currently developed "Design and Implementation of Cloud based Digital Energy meter using ESP8266" this is addressable for both consumer and the electricity board. The paper mainly deals with the embedded system of hardware and software enabled system on the basis of cloud computing with Node MCU module as source of Wi-Fi access. With the help of Node MCU the data can accessed through both mobile application and Web page. The usage notification can be sent in the form of E-mail and application notification. This system will read the monthly energy usage of a consumer automatically and send the information to Electricity board. This can be achieved through Wi-Fi Module and Arduino that can continuously monitor the

electricity usage with cloud storage. This can be displayed on web page and E-mail on customer request.

## II. OBJECTIVES

The main objectives of using IOT based Wireless Energy Meter is to save energy and also in this modern appliance we can send the data using wireless communication where the monitoring and analyzing of data will be made much easier. In this device data, can be stored and retrieved whenever the data is required. This project can be used in remote locations and this has more advantages than traditional energy meter.

## III. BLOCK DIAGRAM

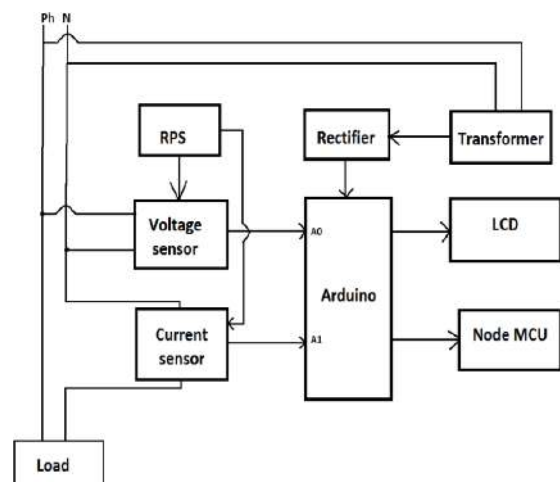

## IV. METHODOLOGY

Here, we describe a Wireless Digital Energy meter using Arduino and ESP8266 NODE MCU [3] which can monitor the energy usage in real time and can send Emails of electricity bill to any location at a single touch point. MQTT Dashboard Android App can be used to monitor our Energy usage. Cloud Based Digital Wireless Energy Meter can be used to monitor using from anywhere in the world and also triggers an alert Email when the Electricity consumption is high.

**Revised Manuscript Received on March 30, 2020.**

**P. Ramesh Babu**, Electrical and Electronics Engineering, Saranathan College of Engineering, Trichy, India. Email:ramnira@gmail.com

**A. Pradeep**, Electrical and Electronics Engineering, Saranathan College of Engineering, Trichy, India. Email: pradeepaakash7@gmail.com

**P. Rajendra Prasath**, Electrical and Electronics Engineering, Saranathan College of Engineering, Trichy, India. Email: rajendraprasath8199@gmail.com

**R. Rishikesh kumar**, Electrical and Electronics Engineering, Saranathan College of Engineering, Trichy, India. Email: rishi.ranjith1988@gmail.com

**J.Sharvin**, Electrical and Electronics Engineering, Saranathan College of Engineering, Trichy, India. Email: jayasharvin@gmail.com

# Wireless Battery Monitoring System with Live Tracking for an Electric Vehicle

<sup>1</sup>\*S.Ramprasath, <sup>2</sup>Dr.C.Krishnakumar, <sup>3</sup>P.Rameshbabu

<sup>1,2</sup>Electrical and Electronics Engineering,  
<sup>1, 2, 3</sup> Saranathan college of Engineering, Trichy, India

**Abstract:** *This paper presents a system to govern the battery parameters like voltage, charging/discharging current, temperature and location which helps in tracking the vehicle. In the developing technological sectors, electric vehicle is taking up its fast approach to its peak in the market and it's important to protect the system from fault and alerting the system. The major cost investment for an electric Vehicle is their Li-Ion batteries costs about half the total investment for the vehicle. Hence it's necessary to propose a Wireless battery management system (WBMS) which monitor the battery performance and for protection which increases longevity of the battery present in the electric vehicle. In our project we propose a control monitoring system which sense the live parameters and monitors remotely using ESP8266 Wi-Fi module interfaced with Arduino Uno Board. We use Blynk app to interface with different sensors. The completed model is place in our electric vehicle built to Participate in NSVU event help in Nagpur and won second overall prize.*

**Keywords:** Battery, Li-ion, Blynk app

## 1. Introduction

In focus towards e-vehicle the major sector to be concentrated is battery. To examine the battery and its related parameters a flexible and compact system is build. Battery plays a major role in the operation of the e-vehicle, it is essential to govern the battery parameters and expand the life time of a battery. The quest to increase the span of an e-vehicle can be solved by governing the battery parameters related to voltage and current [1]. To process the same we need an interfacing medium which transmits the information to our smartphone. Blynk is the interfacing app which facilitates the interfacing between the system and smartphone. This app must be installed in our mobile phone to get the voltage and current parameters with the live location of our vehicle. In battery monitoring system we are about to implement a system that monitors the discharging voltage of the battery, current of the battery and live tracking of our car. Thus the life span of the electric vehicle can be protected from the undesired problems. Sensors are used to sense the parameters like current and voltage. Live tracking is also implemented to get the live location of our car. GPS module is used for tracking [2]. By doing this the life span of the battery can be increased with an added advantage of guiding the people with good platform. Cell balancing, Malfunction indication, status indication can be maintained.

In Electric Vehicles (EVs) the cells are connected in series-parallel combination to build high voltage and large capacity battery packs [3]. Factors causing cell voltage variation includes manufacturing methods, maintenance procedure and aging. In drive mode, these cells undergo electric and thermal ill-treatment due to the unpredictable load variations. In order to meet safety standards and to increase the battery life, a battery monitoring system (BMS) [4], [5] which properly monitors and controls each cell at every instant is mandatory. The WBMS was designed to minimize the Functionality of the slave module to only perform simple commands and send cell operating parameters. The master module is responsible for interpreting all of the data and deciding upon the actions the slave module should be taking [6], [7]. Figure 1 shows the overall block diagram of proposed WBMS. The proposed WBMS consists of a) Sensing module, b) Power supply module, c) Wireless Bluetooth module.

# A Simplified Beginner's Guidelines for Design and Fabrication of Prototype Electrical Vehicle

Proceedings of International Conference on Power Electronics and Renewable Energy Systems pp 271-281 | Cite as

- P. Ramesh Babu (1)
- P. Vigneshwar (1)
- R. Udaya Simha (1)
- S. Tanweer Ahamed (1)
- S. Vengatesh (1)
- V. Vijay (1)

1. Saranathan College of Engineering, , Trichy, India

Conference paper

First Online: 22 November 2021

- 75 Downloads

Part of the [Lecture Notes in Electrical Engineering](#) book series (LNEE, volume 795)

## Abstract

The aim of this paper is to build a prototype electric vehicle out of structural materials. It is influential in the development of a modern, safe, and environmentally sustainable mode of public mobility. The objective of its design is to create a lightweight, compact three-wheeled electric vehicle frame. The design phase entails the creation of a 3D model, a practical prototype, and frame refinement using CAD software and the material parameters. The electrical and mechanical study is performed, the results recorded 125 km per charge, and the weight of the vehicle is 180 kg. The top speed is 40kmph along with >80% efficiency of the BLDC hub motor.

## Keywords

Electric vehicle Lithium-ion battery BLDC hub motor Suspension Steering

This is a preview of subscription content, [log in](#) to check access.

## Notes

## Acknowledgements

[Google Scholar](https://scholar.google.com/scholar?q=Chan%20CC%2C%20Chau%20KT%20%282001%29%20Modern%20electric%20vehicle%20technology%20%28No.%2047%29.%20Oxford%20University%20Press%20on%20Demand) (https://scholar.google.com/scholar?q=Chan%20CC%2C%20Chau%20KT%20%282001%29%20Modern%20electric%20vehicle%20technology%20%28No.%2047%29.%20Oxford%20University%20Press%20on%20Demand)

12. Prabhu VN, Manigandan N (2014) Design and fabrication of solar transport vehicle. *OSR J Mech Civ Eng* 11:14–19

[Google Scholar](http://scholar.google.com/scholar_lookup?title=Design%20and%20fabrication%20of%20solar%20transport%20vehicle&author=VN.%20Prabhu&author=N.%20Manigandan&journal=OSR%20J%20Mech%20Civ%20Eng&volume=11&pages=14-19&publication_year=2014) (http://scholar.google.com/scholar\_lookup?title=Design%20and%20fabrication%20of%20solar%20transport%20vehicle&author=VN.%20Prabhu&author=N.%20Manigandan&journal=OSR%20J%20Mech%20Civ%20Eng&volume=11&pages=14-19&publication\_year=2014)

## Copyright information

© The Author(s), under exclusive license to Springer Nature Singapore Pte Ltd. 2022

## About this paper

Cite this paper as:

Ramesh Babu P., Vigneshwar P., Udaya Simha R., Tanweer Ahamed S., Vengatesh S., Vijay V. (2022) A Simplified Beginner's Guidelines for Design and Fabrication of Prototype Electrical Vehicle. In: Subramani C., Vijayakumar K., Dakyo B., Dash S.S. (eds) *Proceedings of International Conference on Power Electronics and Renewable Energy Systems. Lecture Notes in Electrical Engineering*, vol 795. Springer, Singapore. [https://doi.org/10.1007/978-981-16-4943-1\\_25](https://doi.org/10.1007/978-981-16-4943-1_25)

- First Online 22 November 2021
- DOI [https://doi.org/10.1007/978-981-16-4943-1\\_25](https://doi.org/10.1007/978-981-16-4943-1_25)
- Publisher Name Springer, Singapore
- Print ISBN 978-981-16-4942-4
- Online ISBN 978-981-16-4943-1
- eBook Packages [Energy](#) [Energy \(RO\)](#)
- [Reprints and Permissions](#)

## Personalised recommendations

### SPRINGER NATURE

© 2020 Springer Nature Switzerland AG. Part of [Springer Nature](#).

Not logged in Not affiliated 162.216.140.7



Institutional Sign In

All



ADVANCED SEARCH

Conferences > 2021 2nd International Confer... ?

# Simulation and Steady State Analysis of SIMO Boost Converter for Electric Vehicles

Publisher: IEEE

Cite This

PDF

C. Keerthika ; S. Ramprasath ; P. Rameshbabu ; C. Krishnakumar All Authors



## Alerts

Manage Content Alerts

Add to Citation Alerts

### More Like This

Discussions on control loop design in average current mode control [PWM DC/DC power converters]  
Conference Record of the 2000 IEEE Industry Applications Conference. Thirty-Fifth IAS Annual Meeting and World Conference on Industrial Applications of Electrical Energy (Cat. No.00CH37129)  
Published: 2000

Key components of modular propulsion systems for next generation electric vehicles  
CPSS Transactions on Power Electronics and Applications  
Published: 2017

Show More

76 Full Text Views

Abstract



Downl

PDF

Document Sections

- I. Introduction
- II. Simo Converter Topology
- III. Steady State Analysis
- IV. Simulation Results
- V. Conclusion

**Abstract:**Extreme environmental and human life issues such as global warming, air pollution and the rapid loss of oil resources in the planet are caused by the vast number of cars ... **View more**

### Metadata

**Abstract:** Extreme environmental and human life issues such as global warming, air pollution and the rapid loss of oil resources in the planet are caused by the vast number of cars used. To overcome these issues traditional vehicles have been replaced by the Electric vehicles (EVs). To communicate the elements in the E-Vehicle DC-DC converters are used, by increasing or decreasing the input voltage levels. In order to efficiently reduce the quantity of electronic components to get different output voltages, Single-input Multiple-output DC-DC converters have been developed, also reduces cost. The SingleInput Multi-Output(SIMO) dc-dc converter delivers various levels of output voltage required by the load from a single source of dc input voltage. There are many SIMO topologies were evolved. In order to achieve the above limitations, in this project our work is to model a Single-Input Multiple-Outputs Boost converter. The suggested converter would uplift the voltage to a controllable middle voltage and high voltage dc output from a low voltage input power source. To validate the proposed topology for real time applications, the proposed converter is simulated in the MATLAB application.

**Published in:** 2021 2nd International Conference for Emerging Technology (INCET)

Authors

Figures

References

Keywords

Metrics

More Like This



**Date of Conference:** 21-23 May 2021 **INSPEC Accession Number:** 20867097  
**Date Added to IEEE Xplore:** 22 June 2021 **DOI:** 10.1109/INCET51464.2021.9456358  
**► ISBN Information:** **Publisher:** IEEE  
**Conference Location:** Belagavi, India

---

C. Keerthika  
Saranathan College of Engineering, Trichy, India

---

S. Ramprasath  
Saranathan College of Engineering, Trichy, India

---

P. Rameshbabu  
Saranathan College of Engineering, Trichy, India

---

C. Krishnakumar  
Saranathan College of Engineering, Trichy, India

---

## Contents

### I. Introduction

In recent years, the transportation requirement increases all around the world. This increasing number of automobile usage also increases the environmental pollution, depletion of fossil fuels and also affects the human life. Finding possible solution for these problems led to increasing interest in the electric vehicle (E-Vehicle). The increased requirement for electric vehicles has brought many different problems in the electric vehicle technology [1–3]. Conversion of the battery voltage level in electric vehicles to other different necessary voltage levels with dc-dc converters is one of the issues. As a solution, for each voltage level, a separate converter can be used [4–8]. But the method of control is more difficult and more expensive. However, it is possible to use SIMO (Single-Input Multi-Output) converters. Therefore, a lot of progress and analysis for the development of SIMO converters in various aspects has been done in the recent past.

---

### Authors

C. Keerthika  
Saranathan College of Engineering, Trichy, India

---

S. Ramprasath  
Saranathan College of Engineering, Trichy, India

---

P. Rameshbabu  
Saranathan College of Engineering, Trichy, India

---

C. Krishnakumar  
Saranathan College of Engineering, Trichy, India

---

### Figures

---

### References

# SINGLE PHASE MULTILEVEL INVERTER BASED ON A NOVEL SWITCHING SCHEME USING BUCK CONVERTER

Paranthagan.B<sup>1</sup>, Vijayalakshmi.S<sup>2</sup>, Marimuthu.M<sup>3</sup>, Vijay.R<sup>4</sup>, Satheesh.R<sup>5</sup>

<sup>1</sup>Department of Electrical and Electronics Engineering, Saranathan College of Engineering, Trichy, Tamilnadu, India, Mail id: [paranthagan-eee@saranathan.ac.in](mailto:paranthagan-eee@saranathan.ac.in)

<sup>2</sup>Department of Electrical and Electronics Engineering, Saranathan College of Engineering, Trichy, Tamilnadu, India, Mail id: [bksvijji@gmail.com](mailto:bksvijji@gmail.com)

<sup>3</sup>Department of Electrical and Electronics Engineering, Saranathan College of Engineering, Trichy, Tamilnadu, India, Mail id: [marimuthueeephd@gmail.com](mailto:marimuthueeephd@gmail.com)

<sup>4</sup>Department of Electrical and Electronics Engineering, Saranathan College of Engineering, Trichy, Tamilnadu, India, Mail id: [vijay-eee@saranathan.ac.in](mailto:vijay-eee@saranathan.ac.in)

<sup>5</sup>Department of Electrical and Electronics Engineering, Saranathan College of Engineering, Trichy, Tamilnadu, India, Mail id: [satheesh-eee@saranathan.ac.in](mailto:satheesh-eee@saranathan.ac.in)

**Abstract**— This paper presents a single phase multilevel inverter (MLI) based on a novel switching scheme. This new design produces a substantial decline in the count of power devices and capacitors required to implement a multilevel output battery-powered application. The proposed scheme has two stages namely, DC-DC converter and Inverter. Multilevel are achieved for the inverter by altering duty cycle of the DC-DC converter. In the MATLAB/SIMULINK setting, the proposed idea was implemented and the outcomes were validated.

**Keywords**- DC-DC Converter, Buck Converter, Multilevel Inverter, MATLAB

## I. INTRODUCTION

Due to the benefits of high power waveforms, less harmonic distortion, low common mode voltage, low switching operations, medium, high-voltage and high power capacity, multilevel inverters have become popular in recent years. Usually, an inverter is a system that uses certain electronic circuits to transform DC electrical power into AC type.

Buck converters can be highly efficient (often greater than 90%), making them helpful for tasks such as converting a computer's main (bulk) supply voltage (often 12 V) down to lower USB, DRAM and CPU voltages.. Buck converters are used in self-regulating power supplies and advanced telecom and data-com systems

Generally, a simple inverter provides 2 or 3 output voltage levels. But the multilevel inverter produces 5 levels of output voltage or more. As compared to a 2 stage inverter, it generates a stepped output voltage with reduced harmonic distortion. It offers higher levels of output voltage and power. The inverter requires a fixed dc voltage that can be extracted from the converter.

The multilevel inverter, correlated with lower output harmonics, provides high power capability. Their main downside is their complexity, which includes a large number of power devices and passive parts, as well as a very complex control circuit.

# HIGH FREQUENCY DIRECTION FINDING MILITARY ELECTRONIC VEST

Ramanathan.AL<sup>1</sup>, R.Sridhar<sup>2</sup>, Prithivirajan.E<sup>3</sup>, Poovarasan.R<sup>4</sup>, Naveenkumar<sup>5</sup>,  
<sup>1,3,4,5</sup>Student, <sup>2</sup>Assistant Professor, EEE, Saranathan college of Engineering  
<sup>1</sup>[alagappanramu12@gmail.com](mailto:alagappanramu12@gmail.com), <sup>3</sup>[prithivi.cud@gmail.com](mailto:prithivi.cud@gmail.com)

## ABSTRACT

*The scope of this paper is on the development of electronics that can be inserted into military clothing for protection cum rescuing using GPS module. The manufacturing survey was conducted to determine the best performing and most durable materials, to withstand the rigors of textile manufacturing and potential military use. In our proposal, the physical status of a soldier in the battle field is sensed by sensors and it will be messaged to the nearest base station automatically. By this technique, one can monitor the status of a soldier in the battlefield, and can send the rescue team when needed and the soldiers life can be saved at the earliest.*

## Introduction

During sudden border attacks, large number of soldiers lose their life due to absence of fast rescuing and lack of monitoring soldiers health state in the war zone. By our proposal, one can measure the necessary physiological parameters of the soldiers and can alert the base camp during abnormal condition and can send extra forces or rescue team to the war zone and can save the life of many soldiers.

It enhances the mobility and survivability of soldiers in the war zone. The integration of sensors and other electronic devices in the vest can improve the functionality of soldiers. The proposal functionalities includes soldiers body condition (heart beat rate, body temperature) monitoring, detecting chemical threats, bullet striking. It also provides combat identity. If a soldier is in abnormal state one can rescue him sooner or when a soldier is dead, his corpse can be found easily. By using the air quality sensor in the vest we can also alert the soldiers to take precautions, thus preventing them in losing their life in chemical bombs. The main idea

of the proposal is to provide fast communication using ESP module where the officials can monitor individual soldiers in the base station itself and provide necessary help for the soldiers.

## Operation

The abnormal condition of a soldier is sensed by the various sensors like heart beat sensor, temperature sensor, vibration sensor, air quality sensor. When heart beat exceeds the normal rate the analog signal from the sensor is send to the Arduino board. The temperature sensor measures the body temperature, vibration sensor detects heavy vibration and air quality sensor measures toxicity of air in the surrounding environments and give the corresponding analog signal to the micro controller. The microcontroller produce corresponding digital signal to the LCD display and ESP module. The data are collected in a server through cloud computing process using ESP8266. The data are viewed through the webserver.



Access provided by: Saranathan College of Engineering

Sign Out

All



Conferences > 2021 2nd International Confer... ?

# Dynamic Performance Enhancement of Modified Sepic Converter

Publisher: IEEE

Cite This

PDF

Vijay Ravindran ; RamPrakash Ponraj ; S Syed Zameerbasha ; N Santhosh Kanna ; S ... All Authors

2 Paper Citations

28 Full Text Views

## Abstract

**Abstract:**This paper introduced a non-isolated DC-DC boost converter with high voltage gain and low switching voltage stress for any level of input and output voltage applications.... **View more**

Document Sections

I. Introduction

II. Related Works

### Metadata

#### Abstract:

This paper introduced a non-isolated DC-DC boost converter with high voltage



All



ADVANCED SEARCH

Conferences > 2020 Third International Conf...

# Modified Single Phase Matrix Converter with Z-Source for Renewable Energy Systems

Publisher: IEEE

Cite This

PDF

Titus Sigamani ; Ram Prakash Ponraj ; Vijay Ravindran All Authors

3 Paper Citations

75 Full Text Views

### More Like This

A fuzzy control for a fuel cell generation system based on field programmable gate array  
The 2nd International Symposium on Power Electronics for Distributed Generation Systems  
Published: 2010

Grid Connected Photovoltaic (PV) Inverter with Robust Phase-Locked Loop (PLL)  
2006 IEEE/PES Transmission & Distribution Conference and Exposition: Latin America  
Published: 2006

Show More

### Abstract

**Abstract:**This article terms the use of a buck-boost z-source conversion approach for renewable energy applications with a modified matrix converter topology (MMCT). This system re... **View more**

Document Sections

- I. Introduction
- II. Proposed Topology
- III. Experimental Setup and Results
- IV. Conclusion

### Metadata

#### Abstract:

This article terms the use of a buck-boost z-source conversion approach for renewable energy applications with a modified matrix converter topology (MMCT). This system removes the intermediate DC link and offers direct conversion. The z-source matrix converter (MC) is used to switch the basic frequency and lower the magnetic additive essentials. Within the system provided, the FPGA controller is used to manipulate the excessive-pace control loops for gate pulse generation rather than for the PWM controller. The power converter's total harmonic distortion (THD) is minimized by the use of appropriate filters and techniques that improve the output power quality. As an alternative to the AC-DC-AC converter method, this article addresses the significance of an AC-AC matrix converter as an interface power converter between the variable load and the wind energy network. The new system is related to a conventional system and observed that the proposed topology for the converter that provides better output power in the conversion system for wind energy. MATLAB/S imulink was used to simulate the proposed device, and the tests were checked and analyzed with hardware setup.

**Published in:** 2020 Third International Conference on Smart Systems and Inventive Technology (ICSSIT)

**Date of Conference:** 20-22 Aug. 2020 **INSPEC Accession Number:** 20032333

DOI:

Authors

Figures

References

Citations

Keywords

Metrics

More Like This

# Implementation of AC Voltage Regulator for Three Phase Induction Motor

Bhavadharini P<sup>1</sup>, Haritha R<sup>2</sup>, Vijay R<sup>3</sup>

Student, Electrical and Electronics, Saranathan College of engineering, Tiruchirapalli, India <sup>1</sup>

Student, Electrical and Electronics, Saranathan College of engineering, Tiruchirapalli, India <sup>2</sup>

Professor, Electrical and Electronics, Saranathan College of engineering, Tiruchirapalli, India <sup>3</sup>

**Abstract:** This paper describes a novel method for smooth starting of three phase ac motors. Induction motors are widely used for domestic, industrial and automotive applications. With the advancement in technologies three phase ac motors are having a wide range of applications. Specially designed starters are employed for instantaneous voltage and torque control during starting of three phase ac motors. However, cost effective control over voltage levels during starting is still a far cry. As voltage is directly proportional to speed, we need to control the stator voltage in order to have control over the speed. Thus, our project is all about controlling the stator voltage applied to the motor by phase angle control using TRIACs as a switching device. The semiconductor devices (TRIACs) are triggered by applying a pulse width modulated (PWM) signal to the gate terminal whose width is varied with the help of a potentiometer arrangement. In this way our method serves as a cost effective solution for starting low capacity three phase ac motors.

**Keywords:** Phase angle control, Pulse width modulation, Starters

## I. INTRODUCTION

An electric motor converts electrical energy into mechanical energy which is then used to drive different type of loads. Based on the supply, it may be classified as dc and ac motors. Based on the principle of operation ac motors are further being classified into synchronous motors, single phase or three phase ac motors and other special electric motors. Of all these types three phase ac motors are the most widely used electric motor in industry. They are simple, rugged, robust, low priced, easy to maintain and can be manufactured with characteristics to suit most industrial requirements. Besides, they run at essentially constant speed from no load to full load. Three phase ac motors are further being classified into slip ring and squirrel cage induction motors. Like any electric motor they too carry a stator and rotor winding. Only stator winding is fed from the three phase supply. The rotor winding derives its voltage and power from the externally energized stator winding through electromagnetic induction. The starting of induction motors is followed by inrush currents up to 7-10 times the rated current which in turn influences the starting torque to rise up to three times the running torque. The increased torque results in sudden mechanical stress on the machine which leads to reduction in service life. Thus, starters are employed for smooth starting of the three phase machine.

These starters can be mainly classified under two categories electromechanical starters and electronic starters. Electromechanical starters are those that employ external resistance, transformer and contactors giving reduced voltage during starting. Starters like *star delta starter*, *direct on line starter*, *autotransformer starter*, *stator resistance*

*starter and rotor resistance starter (applicable only to slip ring induction motor)* are some of the conventional electromechanical starters. Electronic starters are those that involve the use of semiconductor switches in their operation like the one used in ac voltage controller type starters and other variable frequency drives. Ac voltage soft starters employing semiconductor switches are widely being used to replace the conventional starters owing to their controlled soft starting capability [2]. The selection of starter depends upon the type and size of the motor. This paper introduces a low cost solid state soft starter for three phase induction motor incorporating a three phase ac voltage regulator using TRIAC as the switching device. Earlier the ac voltage regulator systems were designed with a pair of SCRs connected in antiparallel fashion in each of the phases. But, thyristors may affect the operation of the controller due to its poor commutation characteristics and introduction of low order harmonics [1]. In case of IGBT based soft starters the harmonics produced are of higher order and demands filter design of high values [3].

## II. PROPOSED SYSTEM

The proposed system consists of two modules- power circuit module and pulse generation module. The simplified diagram for the proposed system is shown in the figure below. The proposed system is designed such that it is a cost efficient product compared to other systems that are existing now.

### A. BLOCK DIAGRAM



# Implementation of AC Voltage Regulator for Three Phase Induction Motor

Bhavadharini P<sup>1</sup>, Haritha R<sup>2</sup>, Vijay R<sup>3</sup>

Student, Electrical and Electronics, Saranathan College of engineering, Tiruchirapalli, India <sup>1</sup>

Student, Electrical and Electronics, Saranathan College of engineering, Tiruchirapalli, India <sup>2</sup>

Professor, Electrical and Electronics, Saranathan College of engineering, Tiruchirapalli, India <sup>3</sup>

**Abstract:** This paper describes a novel method for smooth starting of three phase ac motors. Induction motors are widely used for domestic, industrial and automotive applications. With the advancement in technologies three phase ac motors are having a wide range of applications. Specially designed starters are employed for instantaneous voltage and torque control during starting of three phase ac motors. However, cost effective control over voltage levels during starting is still a far cry. As voltage is directly proportional to speed, we need to control the stator voltage in order to have control over the speed. Thus, our project is all about controlling the stator voltage applied to the motor by phase angle control using TRIACs as a switching device. The semiconductor devices (TRIACs) are triggered by applying a pulse width modulated (PWM) signal to the gate terminal whose width is varied with the help of a potentiometer arrangement. In this way our method serves as a cost effective solution for starting low capacity three phase ac motors.

**Keywords:** Phase angle control, Pulse width modulation, Starters

## I. INTRODUCTION

An electric motor converts electrical energy into mechanical energy which is then used to drive different type of loads. Based on the supply, it may be classified as dc and ac motors. Based on the principle of operation ac motors are further being classified into synchronous motors, single phase or three phase ac motors and other special electric motors. Of all these types three phase ac motors are the most widely used electric motor in industry. They are simple, rugged, robust, low priced, easy to maintain and can be manufactured with characteristics to suit most industrial requirements. Besides, they run at essentially constant speed from no load to full load. Three phase ac motors are further being classified into slip ring and squirrel cage induction motors. Like any electric motor they too carry a stator and rotor winding. Only stator winding is fed from the three phase supply. The rotor winding derives its voltage and power from the externally energized stator winding through electromagnetic induction. The starting of induction motors is followed by inrush currents up to 7-10 times the rated current which in turn influences the starting torque to rise up to three times the running torque. The increased torque results in sudden mechanical stress on the machine which leads to reduction in service life. Thus, starters are employed for smooth starting of the three phase machine.

These starters can be mainly classified under two categories electromechanical starters and electronic starters. Electromechanical starters are those that employ external resistance, transformer and contactors giving reduced voltage during starting. Starters like *star delta starter*, *direct on line starter*, *autotransformer starter*, *stator resistance starter and rotor resistance starter (applicable only to slip ring induction motor)* are some of the conventional electromechanical starters. Electronic starters are those that involve the use of semiconductor switches in their operation like the one used in ac voltage controller type starters and other variable frequency drives. Ac voltage soft starters employing semiconductor switches are widely being used to replace the conventional starters owing to their controlled soft starting capability [2]. The selection of starter depends upon the type and size of the motor. This paper introduces a low cost solid state soft starter for three phase induction motor incorporating a three phase ac voltage regulator using TRIAC as the switching device. Earlier the ac voltage regulator systems were designed with a pair of SCRs connected in antiparallel fashion in each of the phases. But, thyristors may affect the operation of the controller due to its poor commutation characteristics and introduction of low order harmonics [1]. In case of IGBT based soft starters the harmonics produced are of higher order and demands filter design of high values [3].

# Design and Manufacturing of Electrically Driven ATV for Enhanced Vehicle Performance

Gayathri Natarajan, L.Ashok kumar

**Abstract:** *This paper aims to produce an Electrical all-terrain vehicle with Smart Driver Kit design which is more durable and comfortable to meet the robust conditions of Defense and Forest Sector, not just recreational user market. The Smart Driver Kit design will take this vehicle experience to a new dimension with valuable information about Energy Consumption, Stealth Mode, Real-time Elevation and Terrain Data. The paper implies the prominence of bringing up innovation in terrain vehicles to cover wide range of market preferably terrain based commercial activities. Clear understanding of Vehicle Dynamics and Automotive Design leads us to the development of a product which would fulfill the consumer expectations sought at every level around the globe. The structural integrity and durability of the vehicle of this vehicle would be an advancement for innovation in All-Terrain Vehicle.*

**Keywords:** *All-terrain vehicle, Stealth mode, Smart driver kit, Vehicle dynamics.*

## I. INTRODUCTION

The main objective of the paper is to inspire the future generation researchers and designers to innovate more of electric mobility, create a demand for electric vehicles by encouraging the consumers to opt for electric vehicles irrespective of the nature of work. In a growing lethal environment with dominance of various kind of pollutants than fresh air and several other environmental experts warn that the entire world is at the verge of global warming which could never be revoked to normal habitable environmental conditions after three years if the same environmental policies fail to achieve significant reductions in greenhouse gas emissions.

Lowering emissions globally is a monumental task, but this opportunity to develop an E-ATV further after deep research suggests that it is vital, necessary, desirable and achievable by shifting to electric drive technology of any type of vehicle. [Sayed.B.M, Mohamed Fanni, 2016]. It is designed to handle a wider variety of terrain than most other vehicles [Malmedahl.G, Dembski 2006]. Electrical All-Terrain Vehicle (E-ATV) is slightly different but more versatile than all other existing ATV's.

This E-ATV concept would be a seed for a new revolution in Automobile Industry. In comparison to traditional fuel based ATVs and any other E-ATVs, concept is to be more fuel efficient with great structural integrity to withstand any robust conditions. Incorporation of Electrical Drive Technology would reduce the adverse environmental risks caused due to vehicle based pollutants.

**Revised Manuscript Received on January 05, 2020**

\* Correspondence Author

Gayathri Natarajan, EEE department, Saranathan College of engineering, Trichy, India.

Dr. L.Ashok kumar, EEE department, PSG college of engineering, Coimbatore, India

## II. STRUCTURAL DESIGN AND ANALYSIS OF CHASSIS FRAME

Chassis is the cage on which an automobile is built. The chassis is the rigid structure that supports all other components such as driver cabin, engine, gearbox, front and rear axles, suspension system, steering, drive train, etc. It acts as the main structure for holding all the components against gravitational force of the earth during movement by taking up all the stresses created by different components. It is the three-dimensional arrangement of members of different lengths to obtain a virtually indestructible structure. The main motive of any structure which is to house a living being is the minimizing of the effects caused by the external forces which act on the structure such as impact forces (by external agents), thereby ensuring the maximum safety of the living being. In the case of an automobile, this virtually indestructible structure is to be moved at constant or varying phase with a human housed in it. So, a human being inside such a structure is prone to a lot of forces due to its movement which include impact force, collision, bumps, twisting effects, etc.

The design of a chassis is the most important part of any vehicle fabrication. Any design engineer must have rampant skills to decide on what type of design to create, the feasibility of fabrication of the design, the economic value of certain aspect of design, etc. The design is the part of vehicle development where a design engineer has full freedom of selecting his own touch, also satisfying the functional requirement of the design. It explains about the structural design in the point of view of a consumer who is the final experimenter of our design. In the point of view of an engineer, the main motive is to increase the bending strength, torsional strength of a structure which is necessary to maintain the rigidity, reduce the chance of failure of the design.

A rigid structure of high strength can be obtained by using a material having high magnitude of tensile strength. Steel is one type of material which has high tensile strength but is heavier on the downside. Aluminium on the other hand is light in weight but has a very low value of tensile strength. So, a design engineer must have the capability to balance between strength and weight of a material.

Strength to Weight ratio is one important factor a design engineer must consider before selecting any material for structure design. All-Terrain Vehicles (ATV) are automobiles designed to travel on any terrain conditions without compromising on the performance of the vehicles. In general, these terrains are not suitable for commercial passenger vehicles. The ATVs that traverse on these roads face a number of instances where the structure is subjected





14th Global Congress on Manufacturing and Management (GCMM-2018)

# Design And Manufacturing Of Electrically Driven ATV For Enhanced Vehicle Performance

**Gayathri Natarajan<sup>a</sup> , Dr. L.Ashok kumar<sup>b</sup>**

*Department Electrical and Electronics Engineering Saranathan College of Engineering, India<sup>a</sup>*

*Department Electrical and Electronics Engineering, Psg College of Technology, India<sup>b</sup>*

---

## Abstract

This paper aims to produce an E-ATV with Smart Driver Kit design which is more durable and comfortable to meet the robust conditions of Defense and Forest Sector, not just recreational user market. The Smart Driver Kit design will take ATV experience to a new dimension with valuable information about Energy Consumption, Stealth Mode, Real-time Elevation and Terrain Data. The paper implies the prominence of bringing up innovation in terrain vehicles to cover wide range of market preferably terrain based commercial activities. Clear understanding of Vehicle Dynamics and Automotive Design leads us to the development of a product which would fulfill the consumer expectations sought at every level around the globe. The structural integrity and durability of the vehicle of this vehicle would be an advancement for innovation in All-Terrain Vehicle.

© 2018 The Authors. Published by Elsevier Ltd.

This is an open access article under the CC BY-NC-ND license (<https://creativecommons.org/licenses/by-nc-nd/4.0/>)

Selection and peer-review under responsibility of the scientific committee of the 14th Global Congress on Manufacturing and Management (GCMM-2018).

*Keywords: E-ATV; Stealth mode; Smart driver kit; Vehicle dynamics.*

---

## 1. Introduction

The main objective of the paper is to inspire the future generation researchers and designers to innovate more of electric mobility, create a demand for electric vehicles by encouraging the consumers to opt for electric vehicles irrespective of the nature of work. In a growing lethal environment with dominance of various kind of pollutants than fresh air and several other environmental experts warn that the entire world is at the verge of global warming which could never be revoked to normal habitable environmental conditions after three years if the same environmental policies fail to achieve significant reductions in greenhouse gas emissions. Lowering emissions globally is a monumental task, but this opportunity to develop an E-ATV further after deep research suggests that it is vital, necessary, desirable and achievable by shifting to electric drive technology of any type of vehicle. [1]. It is designed to handle a wider variety of terrain than most other vehicles [2]. Electrical All-Terrain Vehicle (E-ATV) is slightly different but more versatile than all other existing ATV's. This E-ATV concept would be a seed for a new revolution

2351-9789 © 2018 The Authors. Published by Elsevier Ltd.

This is an open access article under the CC BY-NC-ND license (<https://creativecommons.org/licenses/by-nc-nd/4.0/>)

Selection and peer-review under responsibility of the scientific committee of the 14th Global Congress on Manufacturing and Management (GCMM-2018).

# CAPACIOUS SURVEY ON SMART GRID IN GLOBAL ENERGY MARKET

A.Srimathi<sup>1</sup>, N.Gayathri<sup>2</sup>

PG scholar,EEE,Saranathan College of Engineering,Trichy,India<sup>1</sup>  
Assistant professor,EEE,Saranathan College of Engineering,Trichy,India<sup>2</sup>

*Abstract*—The advancement in communication and information technology give us a possible solution for increasing energy demand which toward a “smarter” grid is widely referred to as “smart” grid. Smart grid provides two way communication between consumer and utility, improved market efficiency and integration of sustainable resources. Demand side management is an important feature of smart grid systems. Demand side management persuades the utility consumer to shift their load demand from high peak to low peak hours to bring down their electricity bills, assist user comfort and establish balanced use of energy. This paper deals with the depreciation of energy generation cost, energy consumption cost and energy consumption accomplishing demand side management in smart grid.

*Keywords*—Demand side management (DSM), Smart grid (SG), Demand response.

## I. INTRODUCTION

The traditional electric power grid connects large central generating stations through a highvoltage (HV) transmission lines to a distribution system which feeds customers demand. Inflation in the demands of users for energy have forced government to think for alternative solution. Increased demand refers to the maximum amount of electricity that is being consumed at a given time. The traditional electricity grid suffers from blackouts, brownouts and other reliability issues. We need superior grids to reduce the pressure on power system by making it more reliable and secured. Smart grid is a new technology towards the conventional grids owing to its two way communication and multi-featured properties such as sensors placed throughout the lines [1]. SG employs information and communication technology in an automated fashion to improve the efficiency and reliability of electricity [3]. In traditional power grid energy distribution is manually monitored whereas smart grid is self monitored using digital technology which allows to balance power loads, troubleshoot outages and manage distribution without the need for direct intervention from technician [4]. The advantages of smart grid includes renewable energy sources in the generation of power,

less carbon emission, low operating and maintaining cost, affordable capital cost, low energy pricing, increased reliability and power quality, lower peak demand [9]. One of the biggest merits of smart grid is fine-granular measurements. It gives remote measurements and make the operator to handle the load easily. In spite of its potential to increase energy consumption, smart grid harm public health, diminish privacy, grid volatility, make the national utility grid insecure and cause unemployment. Tremendous work has been carried on smart grid that results in micro grids which act as a component of smart grid. They even work when there is no supply from the load side. They have a backup scheme in the form of renewable and non-renewable energy. They help to perform in regions which are not located in proximity to main power grid stations [5]. Still, these grids are facing many issues in the form of economy, security, demands, installations and many more. Important issues that need to be handled on urgent bases are management and billing issues [12]. Technology is one of the important parts of Smart Grid which not only includes the hardware and the software but also the communication capabilities. Technologies include security and privacy for integration of smart grid with cloud computing,

# A Broad Survey on Air Pollution Monitoring and Traffic Management System

Muthu Karuppan N<sup>1</sup>, Leo Aldrinraj A S<sup>2</sup>, Madhanraj S<sup>3</sup>, Manoranjan G<sup>4</sup>,  
Ms Gayathri N<sup>5</sup>

U.G. Student, Department Of Electrical and Electronics Engineering, Saranathan College of Engineering, Trichy, India<sup>1,2,3,4</sup>

Assistant Professor, Department Of Electrical and Electronics Engineering, Saranathan College of Engineering, Nagpur, India<sup>5</sup>

**Abstract:** Air pollution monitoring is one of the most important issues in day to day life. Air pollution monitoring start from conventional way to the most sophisticated computer has been used to monitor the air quality, however the fresh air is necessary for all human being, for that various advanced technology has been used and some of this technology is really useful in order to provide a real time air quality data. Aim of this paper is to highlight some technology which is used for air pollution monitoring in traffic congestion and how effective of these technologies are for creating awareness to the public and securing their lives.

**Keywords:** Air quality, pollution, Real-Time Monitoring, Traffic Management, Smart City.

## I. INTRODUCTION

Environmental monitoring is a systematic approach for observing, studying and analyzing the conditions of the environment. For the healthy human being require to breathe in clean air but due to increasing the transportation system fresh air gets polluted. Transport system makes a huge impact on the environment in which we live. Increase in the vehicle gives rise to increasing traffic-related pollutant emission. Therefore, to track the effect of this pollution on the environment and health of individual it is necessary to track the level of pollution in urban and suburban areas. Many health-related issues are arising from air pollution due to traffic. The major source of air pollution is road traffic emission which emits various gases such as CO(Carbon Monoxide), NOx(Nitrogen Oxides), SOx(Sulphur Oxides). Therefore, air quality monitoring in traffic congested areas is needed in order to provide useful information about pollution and can take appropriate measures to mitigate the negative impact whenever it is necessary. The purpose of monitoring the air quality is to collect the data and also to provide the information which is required by the scientist, planners, policymakers to make a decision on improving and managing the environment [1]. The main mission of the air quality monitoring network is to record the concentration of pollution and other parameter related to

the pollution and deliver this information or data to the public through government to warn against any danger.

## II. NEED FOR MONITORING

Clean air is a vital need for every organism. Contaminated air causes many health problems such as respiratory diseases, lung cancer, stress, blood pressure, etc. Therefore to make any step ahead of controlling the pollution rate it is necessary to monitor the air quality which may help us to reduce the air pollution and to maintain the quality of air. There are various causes of increasing pollution such as gases emitted by the vehicle, chemical discharge from industries, radioactive substance etc. these are the main reasons for polluting the air. The main gases which directly affect the human health are carbon monoxide (CO), hydrogen sulfide, sulfur oxides (SOX), Nitrogen oxides (NOX) and the main contribution of these gases are traffic-related pollutant emission. Tremendous efforts are required to improve the quality of air in both outdoor and indoor environment. Monitoring of the environment has been controlled from the manual to the automatic control in the past decade. There is various improvement in the instrument of environment monitoring but still cannot meet the polluted environment [2].

## III. POLLUTANTS FROM TRAFFIC

Combustion of fuels such as natural gas, gasoline, petrol, diesel fuel, fuel oil, or coal is emitted from the exhausts of the vehicles. According to the type of vehicle, it is discharged into the atmosphere through an exhaust pipe. Motor vehicle emissions are a major ingredient which contributes to air pollution.

Some of the pollutants emitted from traffic:

1) **Carbon monoxide (CO)** – Carbon monoxide is the most common type of fatal air pollutant in many countries. CO is colorless, odorless and tasteless, but highly toxic. The largest anthropogenic source of CO is from vehicle emissions. WHO states that breathing more than 35ppm leads to health issues. Breathing the high

---

## Smart Monitoring to be Incorporated in Existing Public Toilets – Intelligent Toilets

**Gayathri Natarajan**

Assistant Professor

Department of Electrical and Electronics  
Engineering

Saranathan College of Engineering  
Trichy, India

gayathri-eee@saranathan.ac.in

**Dr C KrishnaKumar**

Head of the Department

Department of Electrical and Electronics  
Engineering

Saranathan College of Engineering  
Trichy, India

Krishnakumar-eee@saranathan.ac.in

**Abstract**— Globally many people lack access to basic sanitation facility. The country needs smart and sustainable solution for all the sanitation challenges. Consequently, we propose a smart management system to pull off the inefficiency prevailing in the current toilet monitoring and maintenance system. Our System provides support to manage the multiple restrooms situated across a city by a single person and maintains the restrooms based on parameters like occupancy, cleanliness, availability of water and energy resource management, smart sanitation, effective use of cleaning personnel and the corresponding ratings. So, we propose an IoT based monitoring system with the help of contemporary sensors and then cloud Integrated two-way network will help to create an Intelligent Toilet that can be easily connected with a smart hub.

**Keywords:** cloud, IoT, smart city, smart hub

---

### I. INTRODUCTION

A GDP of a country not only depends on the economic rate or the revenue generated but mainly on the health status of its people. The health status is improved when the Clean Sanitation is maintained. Reports clearly states that major world's population lack access to good sanitation facilities. In India, People practicing open defecation is considerably more. A huge challenge is the proper drainage system with the clean environment which is not provided for the end user. Due to improper maintenance toilets are left unclean and within a given short span of time, the infrastructure tends to fail and people simply stop using the toilets. Consequently, this problem makes the people disfavor upon the government and the society owing to the fact that the existing system remains ineffectual.

We can strongly say that Real-time monitoring, usage of resources, cost factor and is the prime challenge in maintaining toilets in any smart city mission. This obstruction inspired us to move this project which in turn will change the perspective about public toilets.

### II. LITERATURE SURVEY

The importance of water management is explained in [1] and the amount of water necessary to make a toilet bowl clean is discussed. This gives a clean picture of water control to be made. Bad

# Analysis of PV Panel based Bidirectional Converter for Electric Vehicle

Vijayalakshmi S  
Department of EEE  
Saranathan college of Engineering,  
Trichy, India  
bksviji@gmail.com

Shivabalan N  
Department of EEE  
Saranathan college of Engineering,  
Trichy, India  
shivabalan1999@gmail.com

Thayananth.T  
Department of EEE  
Saranathan college of Engineering,  
Trichy, India

Marimuthu M  
Department of EEE  
Saranathan college of Engineering,  
Trichy, India  
marimuthueephd@gmail.com

Shathishkumar VK  
Department of EEE  
Saranathan college of Engineering  
Trichy, India  
shathishgokul@gmail.com

Venugopal. R  
Department of EEE  
Saranathan college of Engineering,  
Trichy, India  
venugopal-eee@saranathan.ac.in

Pravinraj T  
Department of EEE  
Saranathan college of Engineering  
Trichy, India  
pravinprince1122@gmail.com

**Abstract - This paper present an analysis of PV panel based Bidirectional converter for Electric vehicle charging. This system consists of solar cell battery, bidirectional dc -dc converter. A Battery is provided for supply power to dc motor during no sunlight condition. The bidirectional dc-dc converter is working in both charging and discharging the battery and can manage the flow of power in both the direction and hence excess energy from the PV panel can be stored in battery. MPPT controller extract maximum power from the PV module under the impact of varying irradiance and varying the load conditions. Model Performance evaluation and analysis has been done through MatLAB/Simulink**

**Keywords : PV panel, Bidirectional Converter, battery, Maximum Power Point Tracking (MPPT).**

## I. INTRODUCTION

Solar energy becomes the most challenging energy sources. In fact, a lot of domestic & industrial or commercial applications use solar energy. Solar energy is a key source to reduce Co2 emissions. On our country, ICE (Internal combustion Engines) are a major source of pollution, hence Electric vehicles become the promising solution. For many reasons taking into account, environmental and cost considerations, renewable energy sources such as solar energy is preferable to charge plug-in electric vehicles. In India, mostly IC engines where used for the transportation. In order to reduce environmental pollution and climatic change and increasing price of fossil fuels, Indian government encourages to promotes more and more electrical vehicles (EV). The Indian government set a target to accelerate the adoption of Electrical vehicles to reduce pollution and many other advantages like high torque and easy speed control. However, all IC engines have to be replaced by an energy storage battery with the help of suitable converter.

In [1] the authors propose an AC charging station with second life Li-ion battery, integrating solar PV, and wind energy. This station is grid connected which allows the export or import energy depending on the utilization. The authors in [2], [4] a control strategy of a multi-port, grid connected, direct DC PV charging station was proposed, the source of energy here can be either PV panels or AC grid, the transfer of energy from AC grid is bidirectional, hence, PV

energy can be injected on AC grid. These two topologies use many converters, which reduce efficiency. In [5] a charging strategy is proposed to minimize the energy cost, the charging time is divided into intervals to minimize the peak consumption of a fleet of EVs during day time. The charging station in this case is grid connected; in addition, the topology was not given.

The effect of fast charging EVs on the AC grid was investigated in [8]: the charging station in [8] is a DC fast charging, and only the grid is used as energy source. The energy source is not renewable and the efficiency is decreased by using two converters. Four possible architectures for a solar EV charger are proposed and compared in [9], these configurations are also grid connected, two possible choices for interconnection to the AC grid: AC inter-connection or DC inter-connection. The efficiency is decreased by the use of several DC-DC and DC-AC converters.

Our proposed PV fed bidirectional converter for EV vehicle is illustrated in Figure 1. This block diagram consists of PV panel, bidirectional converter, battery, and E-bike. The power from PV panel is irregular in nature, so when solar power generation is higher than the demand of the load, then the surplus energy is served to the battery station via bidirectional converter. Any time when the load demand goes beyond the instantaneous solar power generation, the shortfall of power demand is supplied by the station battery through the converter. When the absence of solar power, the battery power is transferred to the load through bidirectional converter. This study can be done for 1KW Solar charging station to charge electric bikes. P&O algorithm has been used in our system for implementing MPPT, due to its simplicity and less computational demands. Also, no prior knowledge of the PV system is necessary for the algorithm to work. The sun has been playing numerous roles in humane existence.

In this paper, section 2 consists of proposed circuit, section 3 contains simulation circuit and results discussion are carried out in section 4, finally section 5 consists of conclusion.

# A Novel Isolated DC-DC Multi-Level Flyback Converter for Multi-Level Inverter Application

Venugopal R  
Department of Electrical and  
Electronics Engineering  
Saranathan College of Engineering  
Trichy, India  
venugopalramadoss@gmail.com

Dr. Vijayalakshimi S  
Department of Electrical and  
Electronics Engineering  
Saranathan College of Engineering  
Trichy, India  
bksviji@gmail.com

Marimuthu M  
Department of Electrical and  
Electronics Engineering  
Saranathan College of Engineering  
Trichy, India  
marimuthueephd@gmail.com

Chandra Kishore M  
Department of Electrical and  
Electronics Engineering  
Saranathan College of Engineering  
Trichy, India  
chandra.083.ck@gmail.com

Mohammed Rifat Z  
Department of Electrical and  
Electronics Engineering  
Saranathan College of Engineering  
Trichy, India  
rifatzahir@gmail.com

Niresh Shankar P  
Department of Electrical and  
Electronics Engineering  
Saranathan College of Engineering  
Trichy, India  
niresshine@gmail.com

**Abstract --- The main theme of this paper is to present a high voltage gain dc-dc boost converter using flyback and multilevel concept. The proposed converter focuses on multilevel outputs with voltage multiplier cell. The input of the general dc-dc converters is either PV array or battery or fuel cell. The circuit is composed of diodes and capacitors which acts as voltage multiplier and also as a rectifier. The implemented multilevel flyback converter can be connected to an H-bridge forming a multilevel inverter. With the help of a single driven semiconductor switch namely MOSFET, the designed converter can produce a high voltage gain in continuous conduction mode. The proposed multilevel flyback converter has been simulated and verified with theoretical values. The results have been demonstrated in the report.**

**Keywords --- Flyback Converter - Multilevel Flyback - Voltage Multiplier (VM).**

## I. INTRODUCTION

Intergovernmental Panel on Climate Change, regularly access the latest climate science reports for every country which is established in 1988. The earth's average temperature is rising at an unprecedented rate, causing rapid warming and climate changes in the contrary of fossil fuels like coal and petrol. Since 1973, various acts like Air act which aims to control the levels of air pollution through measures of National Ambient Air Quality Standards (NAAQS) and Motor vehicles Act (1988) is aimed to address the vehicular traffic and transportation of hazardous wastes. In order to reduce consumption of fossil fuels, solar cars comes into picture. Hybrid Solar vehicles and Commercial Solar Vehicles are replacing the conventional auto Mobiles. The Solar Vehicles requires a wide range dc input voltages for its operation so the demand for DC-DC Converters are in the rise. Isolated converter which has high voltage is combined with VM cell is implemented in this paper.

The flyback converter is a power supply topology that uses mutually coupled inductor or transformer to store energy. The flyback converters are similar to the booster converters in architecture and performance. However, the primary winding of the transformer replaces inductor while

the secondary provides the output. In the flyback configuration, the primary and secondary windings of transformer are utilized as two separate inductors. The basic flyback converter uses a relatively small number of components. A switching device chops the input DC voltage and the energy in the primary is transferred to the secondary through the switching transformer. A diode in the secondary rectifies the voltage while the capacitor boosts and removes the ripple.

A voltage multiplier is an electrical circuit with combination of capacitor and diode that converts AC electrical power from a lower voltage to a higher DC voltage. Voltage multiplier cells are very much similar to rectifier. Usage in electrical and electronic application such as in microwave ovens, strong electric field coils for cathode-ray tubes, electrostatic and high voltage test equipment, etc. The DC output voltage of a rectifier is limited to the peak value of its sinusoidal input voltage. While combining multiple diodes and capacitors as VM cells, we can effectively multiply the DC output voltage for some odd or even multiples.

## II. DESIGN AND OPERATION OF MULTILEVEL FLYBACK CONVERTER

The overall block diagram for the need of high gain converter is shown in fig 1. The ultimatum of the proposed converter is to design a multilevel flyback converter using voltage multiplier cells. This interlinking of flyback and VM makes it possible to develop any number of levels of output just by adding combinations of diodes and capacitors. The main topology is to terminate the limitation of output.

The circuit is going to be operated in continuous conduction mode. Hence an inductor which act as a filter is connected parallel in the primary side of transformer. The inductor is used to limit high input voltage. A single semiconductor switch N-channel MOSFET has been used to control the pwm. Arduino micro controller has been used to provide gate pulse to the MOSFET. The switching frequency implemented is 50 kHz. The converter can operate in extremely high frequencies and so smaller value of inductor is enough. The circuit diagram has been shown in fig 2.

# IMPLEMENTATION OF P & O ALGORITHM FOR MULTI LEVEL CASCADED- BOOST CONVERTER

Reka.J<sup>1</sup>, Vijayalakshmi.S<sup>2</sup>, Marimuthu.M<sup>3</sup>, Paranthagan.B<sup>4</sup>, Vijay.R<sup>5</sup>, Venugopal.R<sup>6</sup>

<sup>1</sup>Department of Electrical and Electronics Engineering, Cauvery College of Engineering, Trichy, Tamilnadu, India, Mail id: [reka.zenith@gmail.com](mailto:reka.zenith@gmail.com)

<sup>2</sup>Department of Electrical and Electronics Engineering, Saranathan College of Engineering, Trichy, Tamilnadu, India, Mail id: [bksvijji@gmail.com](mailto:bksvijji@gmail.com)

<sup>3</sup>Department of Electrical and Electronics Engineering, Saranathan College of Engineering, Trichy, Tamilnadu, India, Mail id: [marimuthueeephd@gmail.com](mailto:marimuthueeephd@gmail.com)

<sup>4</sup>Department of Electrical and Electronics Engineering, Saranathan College of Engineering, Trichy, Tamilnadu, India, Mail id: [paranthagan-eee@saranathan.ac.in](mailto:paranthagan-eee@saranathan.ac.in)

<sup>5</sup>Department of Electrical and Electronics Engineering, Saranathan College of Engineering, Trichy, Tamilnadu, India, Mail id: [vijay-eee@saranathan.ac.in](mailto:vijay-eee@saranathan.ac.in)

<sup>6</sup>Department of Electrical and Electronics Engineering, Saranathan College of Engineering, Trichy, Tamilnadu, India, Mail id: [satheesh-eee@saranathan.ac.in](mailto:satheesh-eee@saranathan.ac.in)

*Abstract*— Maximum power point (MPP) monitoring is an unavoidable feature of a solar (PV) array energy conversion system. Thus an attempt is made to implement the new multi-level cascaded boost converter for maximum power point tracking. MPPT plays a vital role in Photo Voltaic power system as they provides the maximum power output for PV System for different weather conditions and thereby gives improved array efficiency. The goal is accomplished here by implementing the Perturb & Observe MPPT algorithm, which also provides high voltage gain by the use of the proposed converter circuit. The MATLAB/SIMULINK is used for Testing and Implementing the required objective. The algorithms are implemented in m-file of MATLAB.

**Keywords:** *Photovoltaic Module, Multi Cascaded Boost Converter, MPPT Controller, Perturb and Observe method, PSIM.*

## I. INTRODUCTION

Environmental problems empower the world towards renewable energy production. The sunlight is the huge source of inexhaustible energy and the solar array are handled by the influence of the solar radiation, shading and temperature. Solar energy is effectively utilized by Photovoltaic System. The photovoltaic system is used to get the electrical energy from the PV system and restored in the battery

During the non-availability of solar energy, the battery storage system is used for supplying the power. The electric power obtain from solar panel is maximised using P&O algorithm by MPP Tracking. The DC-DC

# Analysis of PV Panel based Bidirectional Converter for Electric Vehicle

Vijayalakshmi S  
Department of EEE  
Saranathan college of Engineering,  
Trichy, India  
bksviji@gmail.com

Shivabalan N  
Department of EEE  
Saranathan college of Engineering,  
Trichy, India  
shivabalan1999@gmail.com

Thayananth.T  
Department of EEE  
Saranathan college of Engineering,  
Trichy, India

Marimuthu M  
Department of EEE  
Saranathan college of Engineering,  
Trichy, India  
marimuthueephd@gmail.com

Shathishkumar VK  
Department of EEE  
Saranathan college of Engineering  
Trichy, India  
shathishgokul@gmail.com

Venugopal. R  
Department of EEE  
Saranathan college of Engineering,  
Trichy, India  
venugopal-eee@saranathan.ac.in

Pravinraj T  
Department of EEE  
Saranathan college of Engineering  
Trichy, India  
pravinprince1122@gmail.com

**Abstract - This paper present an analysis of PV panel based Bidirectional converter for Electric vehicle charging. This system consists of solar cell battery, bidirectional dc -dc converter. A Battery is provided for supply power to dc motor during no sunlight condition. The bidirectional dc-dc converter is working in both charging and discharging the battery and can manage the flow of power in both the direction and hence excess energy from the PV panel can be stored in battery. MPPT controller extract maximum power from the PV module under the impact of varying irradiance and varying the load conditions. Model Performance evaluation and analysis has been done through MatLAB/Simulink**

**Keywords : PV panel, Bidirectional Converter, battery, Maximum Power Point Tracking (MPPT).**

## I. INTRODUCTION

Solar energy becomes the most challenging energy sources. In fact, a lot of domestic & industrial or commercial applications use solar energy. Solar energy is a key source to reduce Co2 emissions. On our country, ICE (Internal combustion Engines) are a major source of pollution, hence Electric vehicles become the promising solution. For many reasons taking into account, environmental and cost considerations, renewable energy sources such as solar energy is preferable to charge plug-in electric vehicles. In India, mostly IC engines where used for the transportation. In order to reduce environmental pollution and climatic change and increasing price of fossil fuels, Indian government encourages to promotes more and more electrical vehicles (EV). The Indian government set a target to accelerate the adoption of Electrical vehicles to reduce pollution and many other advantages like high torque and easy speed control. However, all IC engines have to be replaced by an energy storage battery with the help of suitable converter.

In [1] the authors propose an AC charging station with second life Li-ion battery, integrating solar PV, and wind energy. This station is grid connected which allows the export or import energy depending on the utilization. The authors in [2], [4] a control strategy of a multi-port, grid connected, direct DC PV charging station was proposed, the source of energy here can be either PV panels or AC grid, the transfer of energy from AC grid is bidirectional, hence, PV

energy can be injected on AC grid. These two topologies use many converters, which reduce efficiency. In [5] a charging strategy is proposed to minimize the energy cost, the charging time is divided into intervals to minimize the peak consumption of a fleet of EVs during day time. The charging station in this case is grid connected; in addition, the topology was not given.

The effect of fast charging EVs on the AC grid was investigated in [8]: the charging station in [8] is a DC fast charging, and only the grid is used as energy source. The energy source is not renewable and the efficiency is decreased by using two converters. Four possible architectures for a solar EV charger are proposed and compared in [9], these configurations are also grid connected, two possible choices for interconnection to the AC grid: AC inter-connection or DC inter-connection. The efficiency is decreased by the use of several DC-DC and DC-AC converters.

Our proposed PV fed bidirectional converter for EV vehicle is illustrated in Figure 1. This block diagram consists of PV panel, bidirectional converter, battery, and E-bike. The power from PV panel is irregular in nature, so when solar power generation is higher than the demand of the load, then the surplus energy is served to the battery station via bidirectional converter. Any time when the load demand goes beyond the instantaneous solar power generation, the shortfall of power demand is supplied by the station battery through the converter. When the absence of solar power, the battery power is transferred to the load through bidirectional converter. This study can be done for 1KW Solar charging station to charge electric bikes. P&O algorithm has been used in our system for implementing MPPT, due to its simplicity and less computational demands. Also, no prior knowledge of the PV system is necessary for the algorithm to work. The sun has been playing numerous roles in humane existence.

In this paper, section 2 consists of proposed circuit, section 3 contains simulation circuit and results discussion are carried out in section 4, finally section 5 consists of conclusion.



Conferences > 2020 Joint International Conf...

## Performance Comparison of Power Quality Improvement Strategies for Unified Power Quality Conditioner in an Interconnected Distribution System

Publisher: IEEE [Cite This](#) [PDF](#)

Arun Kumar Puliyadi Kubendran; Ashok Kumar Loganathan; S Elam Cheren **All Authors**

1 Paper Citation 92 Full Text Views

**Abstract**

**Abstract:** In current era the operation of power electronic devices in power system is becoming enormous to enhance the utilization of electric power in an interconnected distribution system to increase the reliability of sophisticated lifestyle of deregulated electricity market, which alarms the power system engineers about the impact of power quality issues and the need for improving the quality of electric power supplied to the consumers. The effects produced by the interconnected power system having renewable energy based electric power generating systems and non-linear loads cause harmonics, voltage variations in the system, which can be mitigated with the help of Unified Power Quality Conditioner (UPQC). This paper presents the performance comparison two different control techniques adopted in the design of UPQC namely synchronous detection method (SDM) and instantaneous direct and quadrature (id-q) method. The proposed UPQC mitigates the voltage variations such as voltage sag/swell and harmonics present in an interconnected distribution system and improve the electric power quality supplied to the consumers as per the IEEE standard 519-1992. The application of SDM and id-q method is to generate the compensation current, voltage required by the UPQC and results in the effective elimination of short time voltage variation disturbances and harmonics at the point of common coupling (PCC). The entire system has been modeled using MATLAB SIMULINK environment.

**Document Sections**

- I. Introduction
- II. Upqc
- III. Control Strategies
- IV. Matlab Simulation Design Procedure
- V. Simulation Results Discussion

[Show Full Outline](#)

**More Like This**

- Power system harmonic estimation using neural networks 2007 8th International Conference on Electrical Power Quality and Utilisation Published: 2007
- Design And Development Of Interconnected Renewable Energy Sources Focused On Grid Power Inverter Energy For Sustainable Development A Review 2020 4th International Symposium on Multidisciplinary Studies and Innovative Technologies (ISMST) Published: 2020

[Show More](#)

link.springer.com/chapter/10.1007/978-3-030-24051-6\_2

Springer Link

Search  [Log in](#)



[International Conference on Artificial Intelligence, Smart Grid and Smart City Applications](#)  
 ... AISGSC 2019 2019: [Proceedings of International Conference on Artificial Intelligence, Smart Grid and Smart City Applications](#) pp 11-19 | [Cite as](#)

## LVRT Capability Improvement in a Grid-Connected DFIG Wind Turbine System Using Neural Network-Based Dynamic Voltage Restorer

Authors [Authors and affiliations](#)

Arun Kumar Puliyadi Kubendran, L. Ashok Kumar

Conference paper  
 First Online: 13 March 2020

1 Citations 618 Downloads

**Abstract**

The wind power plant is one of the fastest growing electrical power sources. The integration of wind turbine into the power grid originates various power quality problems. Low-voltage ride

Chapter EUR 24.95  
 Price excludes VAT (India)

- DOI: 10.1007/978-3-030-24051-6\_2
- Chapter length: 9 pages
- Instant PDF download
- Readable on all devices
- Own it forever
- Exclusive offer for individuals only
- Tax calculation will be finalised during checkout

[Buy Chapter](#)

[eBook](#) EUR 181.89

[Softcover Book](#) EUR 159.99

[Hardcover Book](#) EUR 219.99

[Learn about institutional subscriptions](#)



International Conference on Artificial Intelligence, Smart Grid and Smart City Applications  
AISGSC 2019 2019: [Proceedings of International Conference on Artificial Intelligence, Smart Grid and Smart City Applications](#) pp 21-29 | [Cite as](#)

## Detection and Classification of Power Quality Events Using Wavelet Energy Difference and Support Vector Machine

Authors [Authors and affiliations](#)

Arun Kumar Pullyadi Kubendran, L. Ashok Kumar

Conference paper

First Online: 13 March 2020

1 Citations 610 Downloads

### Abstract

Detection and classification of power quality events (PQE) to improve the quality of electric

- Chapter EUR 24.95  
Price excludes VAT (India)
- DOI: 10.1007/978-3-030-24051-6\_3
- Chapter length: 9 pages
- Instant PDF download
- Readable on all devices
- Own it forever
- Exclusive offer for individuals only
- Tax calculation will be finalised during checkout

Buy Chapter

- > eBook EUR 181.89
- > Softcover Book EUR 159.99
- > Hardcover Book EUR 219.99

[Learn about institutional subscriptions](#)



**SARANATHAN COLLEGE OF ENGINEERING**  
**DEPARTMENT OF EEE**  
**LIST OF PATENTS PUBLISHED BY STAFF MEMBERS**

<u>S.No</u>	<b>Member</b>	<b>Title of the Patent</b>	<b>Patent Office</b>	<b>Patent No.</b>
1	Dr.M.V.Suganyadevi	Analysis with Advanced	IPR	2.02041E+11
2	Dr.S.Vijayalakshmi	POPCORN VENDING	IPR	202141011472 A
		SEWING MACHINE	IPR	202141025388A
3	Dr. M.Marimuthu	POPCORN VENDING	IPR	202141011472 A
		SEWING MACHINE	IPR	202141025388A
		Visually Impaired People	IPR	2.02141E+11
		MOTORIZED MOBILE	IPR	2.02141E+11
		for Hotels and Houses Using	IPR	2.02141E+11
4	Mr. Venugopal R	POPCORN VENDING	IPR	202141011472 A
5	Mr.R.Satheesh	POPCORN VENDING	IPR	202141011472 A
		for Hotels and Houses Using	IPR	2.02141E+11
6	B.PARANTHAGAN	POPCORN VENDING	IPR	202141011472 A
7	B.PARANTHAGAN	for Hotels and Houses Using	IPR	2.02141E+11
7	Dr.P. Ram Prakash	Vending Machine Cart	IPR	202141011472 A
		Visually Impaired People		2.02141E+11
		for Hotels and Houses Using		2.02141E+11
8	R.VIJAY	Vending Machine Cart	IPR	202141011472 A
		Visually Impaired People	IPR	2.02141E+11
		With Body Temperature	IPR	339301-001
		for Hotels and Houses Using	IPR	2.02141E+11
9	N.Gayathri	Cam washer for refrigerator Door	IPR	339928-001
10	Dr.C. Krishnakumar	WOMEN SAFETY COPTER.	IPR	2.02141E+11
	P. Ramesh Babu			
	S.Ramprasath			
	R. Sridhar			
	R.Balasubramanian			
11	Dr.M.V.Suganyadevi	<b>Motorized Mobile Vending</b>	IPR	2.02141E+11

<b>Filing/Publishin</b>	<b>Status</b>
Oct-02-2020	Published
26-03-2021	Published
25.06.2021	Published
26-03-2021	Published
25.06.2021	Published
07-05-2021	published
5.11.2021	Published
3.12.2021	Published
26-03-2021	Published
26-03-2021	Published
3.12.2021	Published
26-03-2021	Published
3.12.2021	Published
26-03-2021	Published
07-05-2021	Filled
3.12.2021	Published
26-03-2021	Published
07-05-2021	Filled
18-02-2021	Filled
26-03-2021	Published
20-04-2021	filled
26/11/2021	Published (Request Under Examination)
5/11/21	Published

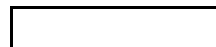



Office of the Controller General of Patents, Designs & Trade Marks  
Department of Industrial Policy & Promotion,  
Ministry of Commerce & Industry,  
Government of India

(<http://ipindia.nic.in/index.htm>)



(<http://ipindia.nic.in/index.htm>)

#### Application Details

APPLICATION NUMBER	202041043071
APPLICATION TYPE	ORDINARY APPLICATION
DATE OF FILING	04/10/2020
APPLICANT NAME	1 . Dr.M.V.Suganyadevi 2 . Dr.R.Ramya 3 . Ms.C.Santhiya 4 . Dr. Arun Raj Lakshminarayanan 5 . Mr. Saravanan Parthasarathy 6 . Mr. Selvaprabu Jeganathan
TITLE OF INVENTION	BRAIN CANCER DETECTION AND ANALYSIS WITH ADVANCED IMAGING TECHNOLOGIES IOT
FIELD OF INVENTION	COMPUTER SCIENCE
E-MAIL (As Per Record)	gladispushparathi@gmail.com
ADDITIONAL-EMAIL (As Per Record)	gladispushparathi@gmail.com
E-MAIL (UPDATED Online)	
PRIORITY DATE	
REQUEST FOR EXAMINATION DATE	--
PUBLICATION DATE (U/S 11A)	09/10/2020

#### Application Status

APPLICATION STATUS	<b>Awaiting Request for Examination</b>
--------------------	---

[View Documents](#)

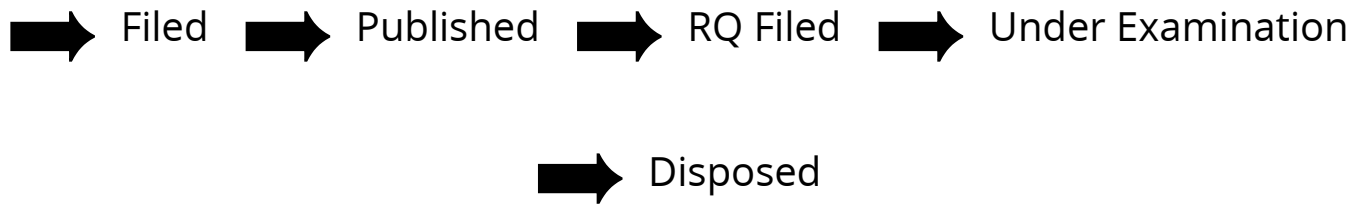

In case of any discrepancy in status, kindly contact [ipo-helpdesk@nic.in](mailto:ipo-helpdesk@nic.in)



Office of the Controller General of Patents, Designs & Trade Marks  
Department of Industrial Policy & Promotion,  
Ministry of Commerce & Industry,  
Government of India

(<http://ipindia.nic.in/index.htm>)



(<http://ipindia.nic.in/index.htm>)

Application Details	
APPLICATION NUMBER	202141011472
APPLICATION TYPE	ORDINARY APPLICATION
DATE OF FILING	18/03/2021
APPLICANT NAME	1 . MR. M.MARIMUTHU 2 . DR. S.VIJAYALAKSHMI 3 . DR. B.PARANTHAGAN 4 . MR. R.VIJAY 5 . DR. TTM. KANNAN 6 . MR. P.RAMPRAKASH 7 . MR. R.VENUGOPAL 8 . MR. R.SATHEESH
TITLE OF INVENTION	MOBILE SOLAR POWERED POPCORN VENDING MACHINE CART
FIELD OF INVENTION	FOOD
E-MAIL (As Per Record)	
ADDITIONAL-EMAIL (As Per Record)	marimuthueeephd@gmail.com
E-MAIL (UPDATED Online)	
PRIORITY DATE	
REQUEST FOR EXAMINATION DATE	--
PUBLICATION DATE (U/S 11A)	26/03/2021

Application Status	
APPLICATION STATUS	<b>Awaiting Request for Examination</b>

[View Documents](#)

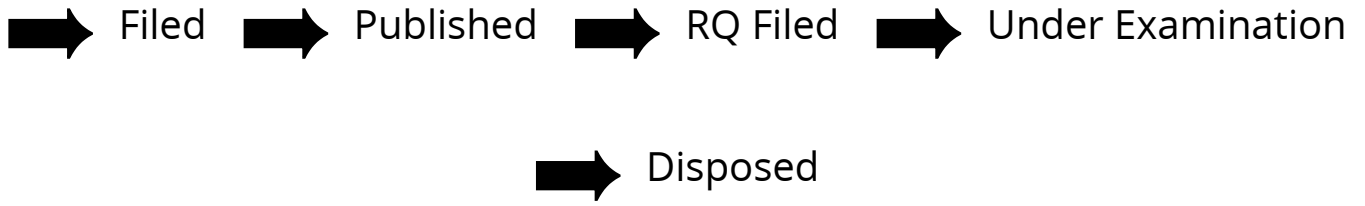

In case of any discrepancy in status, kindly contact [ipo-helpdesk@nic.in](mailto:ipo-helpdesk@nic.in)





Office of the Controller General of Patents, Designs & Trade Marks  
Department of Industrial Policy & Promotion,  
Ministry of Commerce & Industry,  
Government of India

(<http://ipindia.nic.in/index.htm>)



(<http://ipindia.nic.in/index.htm>)

Application Details	
APPLICATION NUMBER	202141025388
APPLICATION TYPE	ORDINARY APPLICATION
DATE OF FILING	08/06/2021
APPLICANT NAME	1 . MR. M. MARIMUTHU 2 . Dr. S. VIJAYALAKSHMI 3 . DR. R. SHENBAGALAKSHMI 4 . Dr. S. SAJU 5 . Dr. TTM. KANNAN 6 . DR. N. VENGADACHALAM 7 . MR. N. JAYAKUMAR 8 . NISHA C RANI 9 . B. DEVI VIGHNESHWARI 10 . A.P. NARMADHA
TITLE OF INVENTION	MOBILE SOLAR POWERED SEWING MACHINE CART
FIELD OF INVENTION	ELECTRICAL
E-MAIL (As Per Record)	
ADDITIONAL-EMAIL (As Per Record)	marimuthueeephd@gmail.com
E-MAIL (UPDATED Online)	
PRIORITY DATE	
REQUEST FOR EXAMINATION DATE	--
PUBLICATION DATE (U/S 11A)	25/06/2021

Application Status	
APPLICATION STATUS	<b>Awaiting Request for Examination</b>

[View Documents](#)

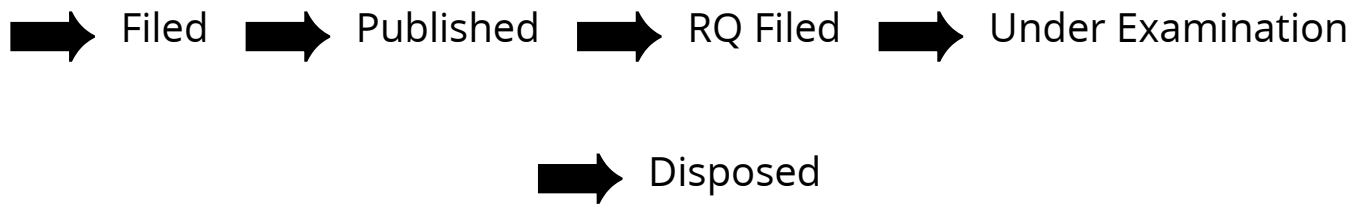

In case of any discrepancy in status, kindly contact [ipo-helpdesk@nic.in](mailto:ipo-helpdesk@nic.in)



Office of the Controller General of Patents, Designs & Trade Marks  
Department of Industrial Policy & Promotion,  
Ministry of Commerce & Industry,  
Government of India

(<http://ipindia.nic.in/index.htm>)



(<http://ipindia.nic.in/index.htm>)

Application Details	
APPLICATION NUMBER	202141050979
APPLICATION TYPE	ORDINARY APPLICATION
DATE OF FILING	08/11/2021
APPLICANT NAME	1 . DR. S. VIJAYALAKSHMI 2 . MR. N. JAYAKUMAR 3 . Dr. B. DEVI VIGNESHWARI 4 . NISHA C RANI 5 . DR. M. MARIMUTHU 6 . B. PARANTHAGAN 7 . R. VIJAY 8 . Dr. P. RAM PRAKASH 9 . R. SATHEESH 10 . SANDHYA RAI
TITLE OF INVENTION	SOLAR POWERED ELECTRIC CHIMNEY FOR HOTELS AND HOUSES USING BLDC MOTOR
FIELD OF INVENTION	MECHANICAL ENGINEERING
E-MAIL (As Per Record)	
ADDITIONAL-EMAIL (As Per Record)	bksvijji@gmail.com
E-MAIL (UPDATED Online)	
PRIORITY DATE	
REQUEST FOR EXAMINATION DATE	--
PUBLICATION DATE (U/S 11A)	03/12/2021

Application Status

APPLICATION STATUS

## Awaiting Request for Examination

[View Documents](#)

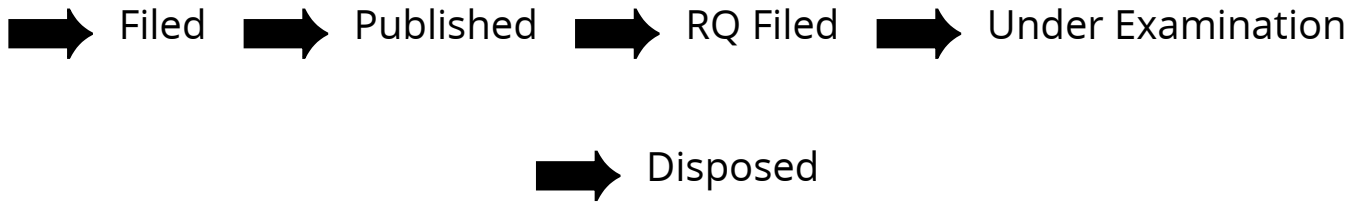

In case of any discrepancy in status, kindly contact [ipo-helpdesk@nic.in](mailto:ipo-helpdesk@nic.in)



Office of the Controller General of Patents, Designs & Trade Marks  
Department of Industrial Policy & Promotion,  
Ministry of Commerce & Industry,  
Government of India

(<http://ipindia.nic.in/index.htm>)



(<http://ipindia.nic.in/index.htm>)

Application Details	
APPLICATION NUMBER	202141020762
APPLICATION TYPE	ORDINARY APPLICATION
DATE OF FILING	07/05/2021
APPLICANT NAME	1 . MR. R. VIJAY 2 . MR. K.SWAMINATHAN 3 . MR. V. RAMKUMAR 4 . DR. C. VENNILA 5 . DR. TTM. KANNAN 6 . MR. M. MARIMUTHU 7 . MR. P. RAWPRAKASH 8 . MR. B. PARANTHAGAN 9 . MR. R. VENUGOPAL 10 . MR. R. SATHEESH
TITLE OF INVENTION	AI BASED VISION GADGET FOR VISUALLY IMPAIRED PEOPLE
FIELD OF INVENTION	PHYSICS
E-MAIL (As Per Record)	
ADDITIONAL-EMAIL (As Per Record)	vijay91mtech@gmail.com
E-MAIL (UPDATED Online)	
PRIORITY DATE	
REQUEST FOR EXAMINATION DATE	--
PUBLICATION DATE (U/S 11A)	18/06/2021

Application Status	
APPLICATION STATUS	<b>Awaiting Request for Examination</b>

[View Documents](#)

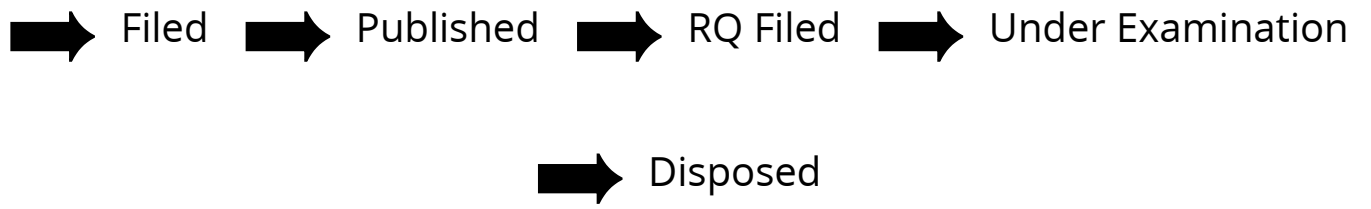

In case of any discrepancy in status, kindly contact [ipo-helpdesk@nic.in](mailto:ipo-helpdesk@nic.in)



ORIGINAL

No. 103952

भारत सरकार  
GOVERNMENT OF INDIA  
पेटेंट कार्यालय  
THE PATENT OFFICE

CERTIFICATE OF REGISTRATION OF DESIGN

Design No. 339301-001  
Date 18/02/2021  
Reciprocity Date\*  
Country

Certified that the design of which a copy is annexed hereto has been registered as of the number and date given above in class 23-08 in respect of the application of such design to HAND SANITIZER DISPENSER WITH BODY TEMPERATURE MEASURING INSTRUMENT in the name of 1. MR. R. VIJAY, DEPT. OF ELECTRICAL & ELECTRONICS ENGG., SARANATHAN COLLEGE OF ENGG., VENKATESHWARA NAGAR, PANJAPPUR, TIRUCHIRAPPALLI-620012, T.N. 2. DR. C. VENNILA, DEPT. OF ELECTRICAL & ELECTRONICS ENGG., SARANATHAN COLLEGE OF ENGG., VENKATESHWARA NAGAR, PANJAPPUR, TIRUCHIRAPPALLI-620012, T.N. 3. S. RAGHAVENDRAN, DEPT. OF ELECTRICAL & ELECTRONICS ENGG., SARANATHAN COLLEGE OF ENGG., VENKATESHWARA NAGAR, PANJAPPUR, TIRUCHIRAPPALLI-620012, T.N. 4. H. M. SUDHAKAR, DEPT. OF ELECTRICAL & ELECTRONICS ENGG., SARANATHAN COLLEGE OF ENGG., VENKATESHWARA NAGAR, PANJAPPUR, TIRUCHIRAPPALLI-620012, T.N. INDIA, ET AL.

in pursuance of and subject to the provisions of the Designs Act, 2000 and the Designs Rules, 2001.

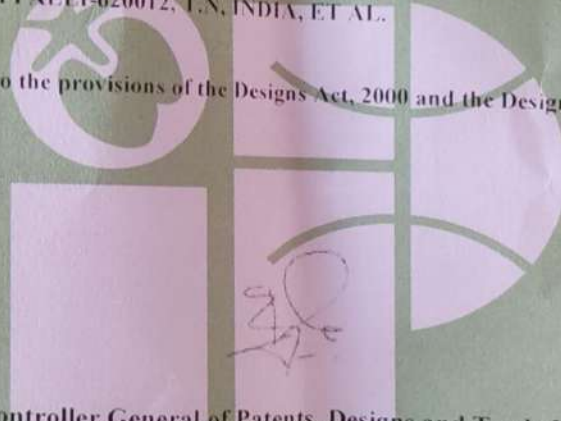

Controller General of Patents, Designs and Trade Marks

\*The reciprocity date (if any) which has been allowed and the name of the country.  
Copyright in the design will subsist for ten years from the date of Registration, and may under the terms of the Act and Rules, be extended for a further period of five years.  
This Certificate is not for use in legal proceedings or for obtaining registration abroad

INTELLECTUAL  
PROPERTY INDIA  
PATENTS | DESIGNS | TRADE MARKS  
GEOGRAPHICAL INDICATIONS

MR. R. VIJAY,  
ASSISTANT PROFESSOR, DEPARTMENT OF ELECTRICAL  
& ELECTRONICS ENGINEERING, SARANATHAN  
COLLEGE OF ENGINEERING, VENKATESHWARA NAGAR,  
PANJAPPUR, TIRUCHIRAPPALLI - 620 012, TAMILNADU,  
INDIA

Date of Issue 28/10/2021 16:25:15

NAME OF THE APPLICANTS

1. Mr.R.VIJAY
2. Dr.C.VENNILA
3. Mr.S.RAGHAVENDRAN
4. Mr.H.M.SUDHAKAR
5. Mr.S.UDHAYAKUMAR

Number of sheets : 1/6  
Sheet Number : 1

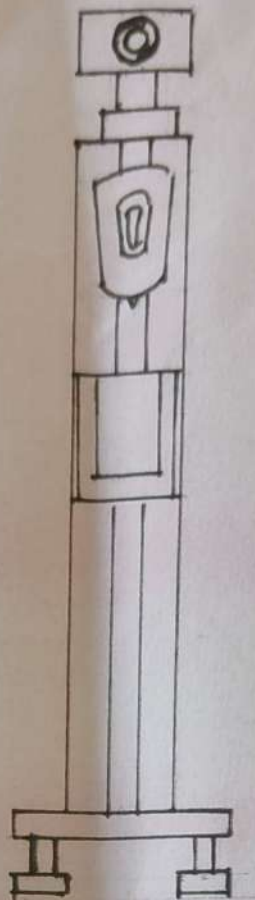

FRONT VIEW

- The novelty resides in shape and configuration of the as illustrated **HAND SANITIZER DISPENSER WITH BODY TEMPERATURE MEASURING INSTRUMENT** as illustrated.
- No claim is made by virtue of this registration in respect of any mechanical or other action of the mechanism whatever or in respect of any mode or principle of construction of the article.
- No claim is made by virtue of the registration to any right to the exclusive use of the words, letters, numbers, color, combination or Trade Marks as appearing in the representation.

DATE: 29-03-2021

SIGNATURE OF THE APPLICANT

1. Mr.R.VIJAY

2. Dr.C.VENNILA

3. Mr.S.RAGHAVENDRAN

4. Mr.H.M.SUDHAKAR

5. Mr.S.UDHAYAKUMAR

339301-001  
18 FEB 2021



(12) PATENT APPLICATION PUBLICATION

(21) Application No.202141051889 A

(19) INDIA

(22) Date of filing of Application :12/11/2021

(43) Publication Date : 26/11/2021

(54) Title of the invention : WOMEN SAFETY COPTER

(51) International classification :B64C0039020000, G08G0001010000, G01S0019130000, H04N0007180000, G05D0001100000  
(86) International Application No :NA  
Filing Date :NA  
(87) International Publication No :NA  
(61) Patent of Addition to Application Number :NA  
Filing Date :NA  
(62) Divisional to Application Number :NA  
Filing Date :NA

(71)Name of Applicant :

**1)YOGESHWARAN MUTHUSELVAN**

Address of Applicant :saranathan college of engineering, panjapur, trichy-620012, tamilnadu -----

Name of Applicant : NA

Address of Applicant : NA

(72)Name of Inventor :

**1)YOGESHWARAN MUTHUSELVAN**

Address of Applicant :saranathan college of engineering, panjapur, trichy-620012, tamilnadu -----

**2)Mr. V. Manoj Kumar**

Address of Applicant :Saranathan college of engineering, Panjapur, Trichy-620012. -----

**3)J. Vasanthakumar**

Address of Applicant :Saranathan college of engineering, Panjapur, Trichy-620012. -----

**4)Mr. P. Rameshbabu**

Address of Applicant :Saranathan college of engineering, Panjapur, Trichy-620012. -----

**5)Mr. R. Balasubramanian**

Address of Applicant :Saranathan college of engineering, Panjapur, Trichy-620012. -----

**6)Dr. C. Krishnakumar**

Address of Applicant :Saranathan college of engineering, Panjapur, Trichy-620012. -----

**7)S. Thirumoorthi**

Address of Applicant :Saranathan college of engineering, Panjapur, Trichy-620012. -----

**8)Mr. S. Ramprasath**

Address of Applicant :Saranathan college of engineering, Panjapur, Trichy-620012. -----

**9)Mr. R. Sridhar**

Address of Applicant :Saranathan college of engineering, Panjapur, Trichy-620012. -----

**10)P. Ponraj**

Address of Applicant :Saranathan college of engineering, Panjapur, Trichy-620012. -----

(57) Abstract :

In this proposed model, an automatic or autonomous drone will be introduced which helps the Women at the time of danger. At the time of danger whomever it may (women or children or men). If they call for help, by recognizing the word help our MIC module will send a signal to the drone about the victim location through GPS module, as soon as the location is received our drone will reach the victim location and take a picture of both victim and assaulter or thief and send the pictures and location to control room. So that the COPS can reach the place easily without time delay and also easy to catch the trouble maker without time lagging and cost. Not only for these purposes, since it's an emerging technology it can also adopt to the customer needs it can also use for the surveillance in high way at the night time because at night time if any accident occurs it goes unnoticed. By using this drone, it can also detect unusual activity in the highway so it can also help to save lives. It can be modified as a soldier drone and it can also be used in battle field instead of our soldiers, so that there won't be any necessary in risking their lives. This entire process is an autonomous one so there will be no need of any additional pilot. Not only for flying for charging also it uses wireless autonomous charge so there will be less maintenance and reasonable initial cost. Nearly we require one drone for monitoring 15 to 20 streets i.e., covering up 5-kilometer radius so it doesn't require many installations area. And also, it has an ultrasonic sensor which avoid obstacles for drone.

No. of Pages : 20 No. of Claims : 7



Office of the Controller General of Patents, Designs & Trade Marks  
 Department of Industrial Policy & Promotion,  
 Ministry of Commerce & Industry,  
 Government of India

(<http://ipindia.nic.in/index.htm>)



(<http://ipindia.nic.in/index.htm>)

### Application Details

APPLICATION NUMBER	202141042029
APPLICATION TYPE	ORDINARY APPLICATION
DATE OF FILING	17/09/2021
APPLICANT NAME	1 . DR.M.MARIMUTHU 2 . DR.S.VIJAYALAKSHMI 3 . AR.DANILA SHIRLY 4 . DR.R.RAMYA 5 . DR.S.USHA 6 . DR.R.SHENBAGALAKSHMI 7 . R.VENUGOPAL 8 . DR.MV. SUGANYA DEVI 9 . C.PEARLINE KAMALINI 10 . N.GAYATHRI
TITLE OF INVENTION	SOLAR POWERED FED MOTORIZED MOBILE VENDING CART FOR GREENGROCERS
FIELD OF INVENTION	COMPUTER SCIENCE
E-MAIL (As Per Record)	
ADDITIONAL-EMAIL (As Per Record)	marimuthueeephd@gmail.com
E-MAIL (UPDATED Online)	
PRIORITY DATE	
REQUEST FOR EXAMINATION DATE	--
PUBLICATION DATE (U/S 11A)	05/11/2021

### Application Status

APPLICATION STATUS

## Awaiting Request for Examination

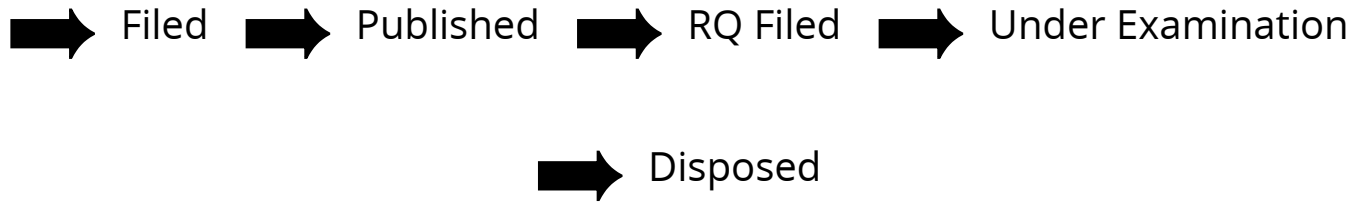
[View Documents](#)

In case of any discrepancy in status, kindly contact [ipo-helpdesk@nic.in](mailto:ipo-helpdesk@nic.in)



Controller General of Patents, Designs and Trademarks  
Department of Industrial Policy and Promotion  
Ministry of Commerce and Industry

## Design Application Details

**Application Number:**

339928-001

**Cbr Number:**

200019

**Cbr Date:**

01/03/2021 15:06:49

**Applicant Name:**

1. Dr. G. Mahesh      2. Dr. D. Valavan      3. Dr. N. Baskar      4. N. Gayathri  
5. Dr. TTM. Kannan

## Design Application Status

**Application Status:**

Case is in Amended Case of Controller

[Back \(/DesignApplicationStatus/\)](#)

Disclaimer: Application status is available for the application filed on or after 1st April 2009 with application no 222230. The information under " Design Application Status" is dynamically retrieved and is under testing, therefore the information retrieved by this system is not valid for any legal proceedings under the Design Act 2000. In case of any discrepancy you may contact the appropriate Patent Office or send your comments to following email IDs:

Design Office, Kolkata : [controllerdesign.ipo@nic.in](mailto:controllerdesign.ipo@nic.in)

Controller General of Patents, Designs and Trademarks